

Bedienungsanleitung

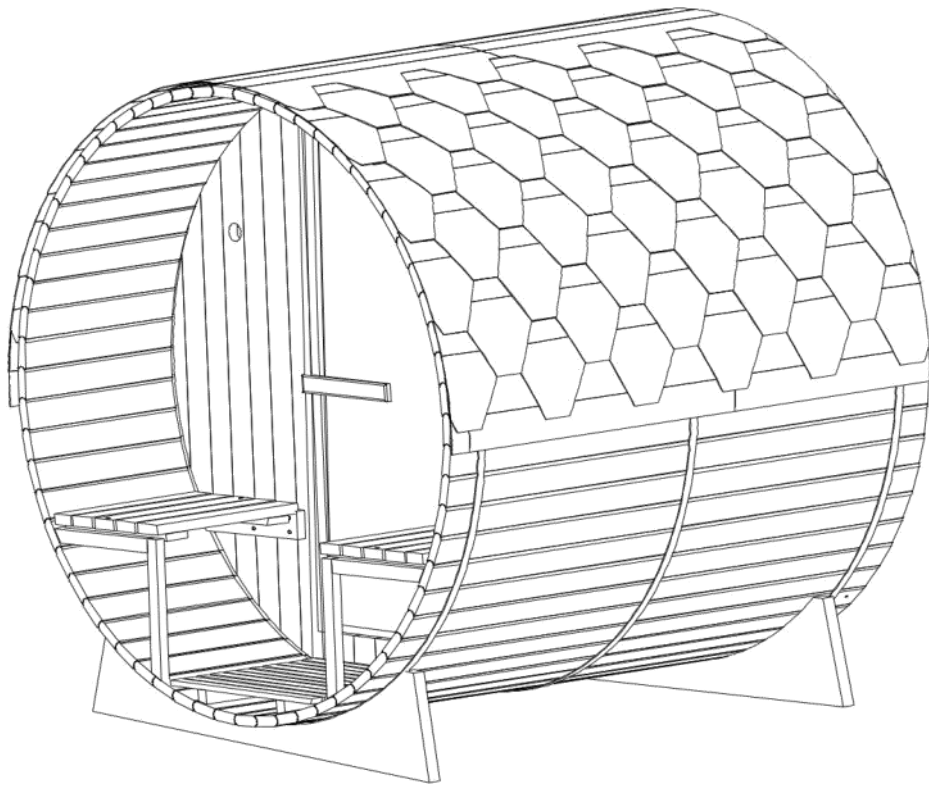

— Infrarot macht das Leben gesünder —

Empfehlungen

Lesen Sie diese Anleitung sorgfältig durch, bevor Sie Ihre Sauna zum ersten Mal in Betrieb nehmen.

Wir empfehlen Ihnen, es an einem sicheren Ort aufzubewahren, damit Sie es in Zukunft wieder verwenden können.

- Holz ist ein lebendiges Element. Um sein ursprüngliches Aussehen zu erhalten, ist es wichtig, die Außenseite des Holzes gegen Feuchtigkeit zu behandeln.
- Stellen Sie die Sauna auf eine vollkommen ebene und harte Fläche.
- Verwenden Sie keine flüssigen Reinigungsmittel. Schalten Sie die Sauna vor der Reinigung aus und verwenden Sie einen feuchten Lappen.
- Schützen Sie das Stromkabel der Sauna, damit es nicht gequetscht oder eingeklemmt wird.
- Vergewissern Sie sich vor dem Austausch bestimmter Bauteile, dass diese vom Hersteller vorgeschrieben sind oder die gleichen Eigenschaften wie die Originalteile haben. Ein falscher Austausch kann einen Brand, einen Kurzschluss oder eine Beschädigung der Sauna verursachen. Wir empfehlen dringend, einen qualifizierten Techniker hinzuzuziehen.
- Um die Gefahr von Verbrennungen oder Stromschlägen zu vermeiden, verwenden Sie keine Metallwerkzeuge
- Tiere dürfen nicht in die Sauna gebracht werden.
- Lassen Sie die Sauna nicht unbeaufsichtigt eingeschaltet.
- Lassen Sie die Sauna nicht länger als 3 Stunden am Stück eingeschaltet, um eine vorzeitige Beschädigung des Geräts zu vermeiden. Schalten Sie die Sauna nach 3 Stunden Dauerbetrieb mindestens eine Stunde lang aus.
- Wir empfehlen Ihnen, kein Schließsystem an der Sauna-Tür anzubringen.
- Überprüfen Sie, ob die elektronischen Teile richtig angeschlossen ist, bevor Sie Ihre Sauna an das Stromnetz anschließen.

Sicherheit

WICHTIG!

Bitte lesen Sie die Sicherheitshinweise sorgfältig durch, bevor Sie Ihre Saunakabine aufstellen und benutzen. Die Hinweise sind wichtig für Ihre Sicherheit, also halten Sie sich bitte strikt an sie ein.

Achten Sie auf Hyperthermie, Hitzschlag oder Hitzeerschöpfung, die durch Nichtbeachtung der Sicherheitshinweise verursacht oder verschlimmert werden können. Die Symptome sind Fieber, schneller Puls, Schwindel, Ohnmacht, Lethargie und Taubheitsgefühl im ganzen Körper oder in Teilen des Körpers. Die Auswirkungen sind: verminderte Wahrnehmung der Hitze, Unkenntnis der drohenden Gefahren, Bewusstlosigkeit.

Die Sauna darf nicht benutzt werden von:

- Kinder unter 6 Jahren.
- Menschen mit starken Reaktionen auf Sonnenlicht.
- Ältere oder behinderte Menschen.
- Personen mit Vorerkrankungen wie Herzkrankheiten, hohem oder niedrigem Blutdruck, Durchblutungsstörungen oder Diabetes ohne vorherige ärztliche Beratung.
- Schwangere Frauen. Überhöhte Temperatur kann den Fötus gefährden.
- Personen, die an Dehydrierung, offenen Wunden, Augenkrankheiten, Verbrennungen oder Sonnenstich leiden.

Kinder zwischen 6 und 16 Jahren dürfen die Sauna benutzen, sofern sie ständig von einem verantwortlichen Erwachsenen beaufsichtigt werden und die Temperatur 60°C nicht überschreitet.

Bei gesundheitlichen Problemen, Medikamenteneinnahme oder Verletzungen von Muskeln und Bändern dürfen Sie die Sauna nur nach vorheriger Rücksprache mit einem Arzt und dessen Genehmigung benutzen.

Wenn Sie chirurgische Implantate tragen, dürfen Sie die Sauna nicht benutzen, ohne vorher einen Arzt zu befragen und dessen Zustimmung einzuholen.

Benutzen Sie die Sauna nicht nach anstrengenden Aktivitäten.

Warten Sie 30 Minuten, bis sich Ihr Körper abgekühlt hat.

Verbringen Sie nicht mehr als 40 Minuten am Stück in der Sauna.

Nehmen Sie vor oder während der Sitzung keinen Alkohol oder Drogen zu sich.

Schlafen Sie nicht in der Sauna, wenn diese in Betrieb ist.

Um die Gefahr einer Überhitzung zu vermeiden, schließen Sie Ihre Sauna an eine ausreichend starke Steckdose an und schließen Sie keine anderen elektrischen Geräte an dieselbe Steckdose an.

Um das Risiko eines Stromschlags oder einer Beschädigung der Sauna zu vermeiden, darf diese nicht benutzt werden:

- Während eines Gewitters.
- Wenn das elektrische Kabel beschädigt ist, muss es von einer qualifizierten Person ersetzt werden.
- Bei Überhitzung des Stromkabels muss es von einer qualifizierten Person überprüft werden.
- Wenn Sie eine Glühbirne wechseln müssen, warten Sie, bis die Sauna ausgeschaltet und abgekühlt ist.

Trocknen Sie sich die Hände, bevor Sie den Strom anschließen oder abschalten.

Niemals mit nassen Händen oder Füßen arbeiten.

Schalten Sie den Strom oder die Heizung nicht schnell ein oder aus, da dies die elektrische Anlage beschädigen könnte.

Versuchen Sie nicht, die Sauna ohne Zustimmung des Saunahändlers oder des Herstellers selbst zu reparieren.

Unerlaubte Reparaturversuche führen zum Erlöschen der Herstellergarantie.

Verwenden Sie keine Reinigungsmittel in der Sauna.







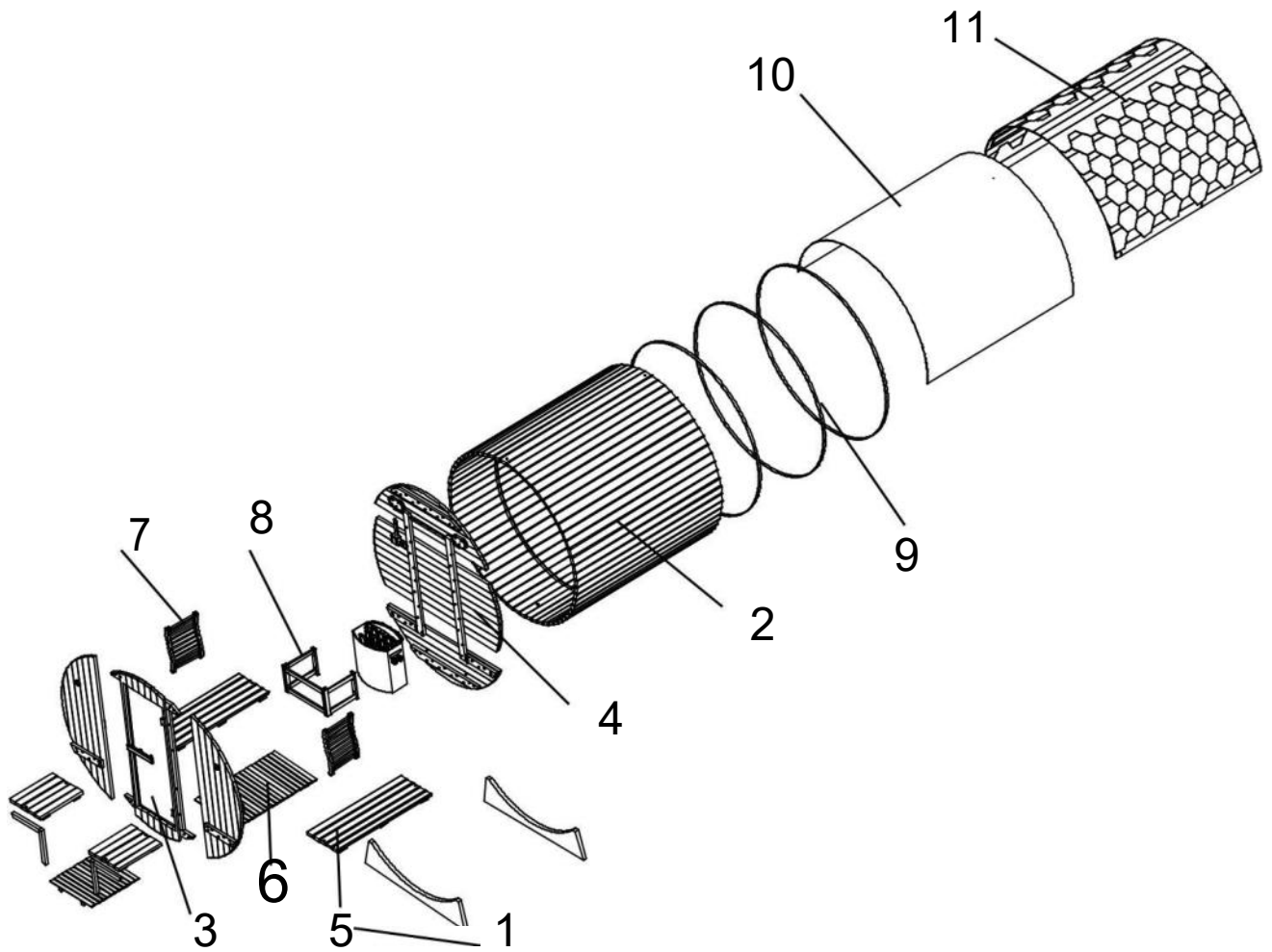



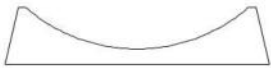

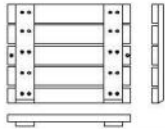
Keine Gegenstände in oder auf der Sauna stapeln oder lagern.

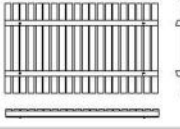
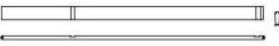
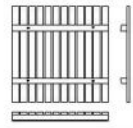
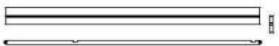
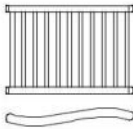
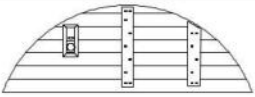
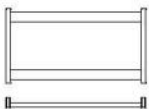
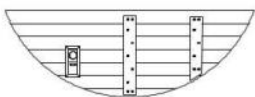
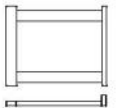
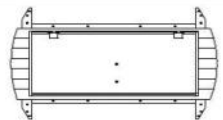
Stellen Sie keine brennbaren Materialien oder chemische Stoffe in der Nähe der Sauna auf.

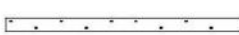
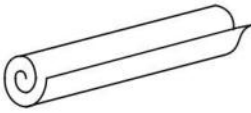

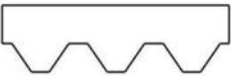
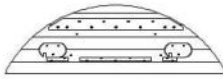
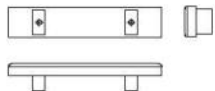

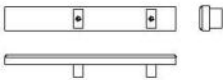
Beschreibung Sauna

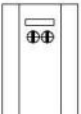
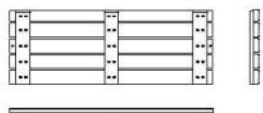
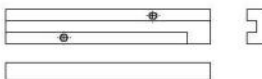



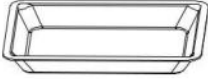
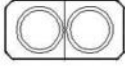
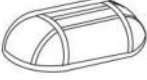

Beschreibung Sauna

1		(1400x300x33mm) 2x	5.2		(426x398x30mm) 2x
2.1		(1800x93x30mm) 2x	5.3		(532x425x50mm) 2x
2.2		(1800x93x30mm) 1x	6.1		(990x585x40mm) 1x
2.3		(1800x93x30mm) 60x	6.2		(535x585x40mm) 1x
2.4		(1800x93x30mm) 1x	7		(520x330x65mm) 2x
3.1		(1758x575x30mm) 1x	8.1		(560x300x40mm) 1x
3.2		(1650x575x30mm) 1x	8.2		(378x300x40mm) 2x
3.3		(1758x952x30mm) 1x	9		3x Fassreifen
4.1		(1404x80x20mm) 1x	10		(3000x1800mm) 1x
4.2		(1404x80x20mm) 1x	11		(1000x320mm) 60x
4.3		(1574x488x30mm) 1x	12		(250x50x45mm) 1x
4.4		(1758x783x30mm) 1x	13		(350x50x45mm) 1x
4.5		(1574x488x30mm) 1x	14		1x Saunaofen
5.1		(1152x425x50mm) 2x	15		(177x80x30mm) 1x

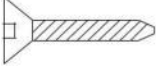
Beschreibung Sauna

16		1x Wasserschale	20		1x Hygrometer
17		2x Explosionsgeschützter Lampenschirm 21			1x Sanduhr
18		2x Becherplatte	22		1x Schöpfer
19		1x Kübel			

							
Ø5x50	Ø4x50	Ø4x30	Ø3x35	Ø4x12	Ø6x70		
44x	20x	8x	66x	240x	2x	2x	

Lesen Sie die Montageanleitung sorgfältig durch, bevor Sie einen geeigneten Platz für Ihre Sauna gefunden haben. Die Sauna ist ausschließlich nur für die Installation im Außenbereich entworfen.

Wählen Sie einen Raum:

- In einem trockenen Raum, auf einer ebenen, stabilen Fläche, die das Gewicht der Sauna tragen kann.
- Die Höhe muss so bemessen sein, dass Sie die Decke erreichen und elektrische Anschlüsse und Wartungsarbeiten durchführen können.
- Nicht in der Nähe von Wasserquellen, Flammen oder brennbaren Materialien.

Praktische Ratschläge

- Beachten Sie, dass für die Montage der Sauna mindestens 3 Erwachsene erforderlich sind.
- Identifizieren Sie jedes Paneel eindeutig, bevor Sie beginnen
- Verlegen Sie bei der Montage das Netzkabel Ihrer Sauna so, dass es leicht zugänglich ist.
- Beachten Sie, dass es Unterschiede zwischen den einzelnen Modellen gibt.

WICHTIG!

Bitte überprüfen Sie den Senkungs- und Lochdurchmesser der Bohrlöcher, um eine Beschädigung des Holzes zu vermeiden.

Benötigte Werkzeuge



Schraubenzieher



Bandmaß



Bleistift



Kutter



2 Schraubenschlüssel



Akkubohrer



Holzspiralbohrer



Inbusschlüssel



Stufenleiter



Schlegel

Montageanleitung

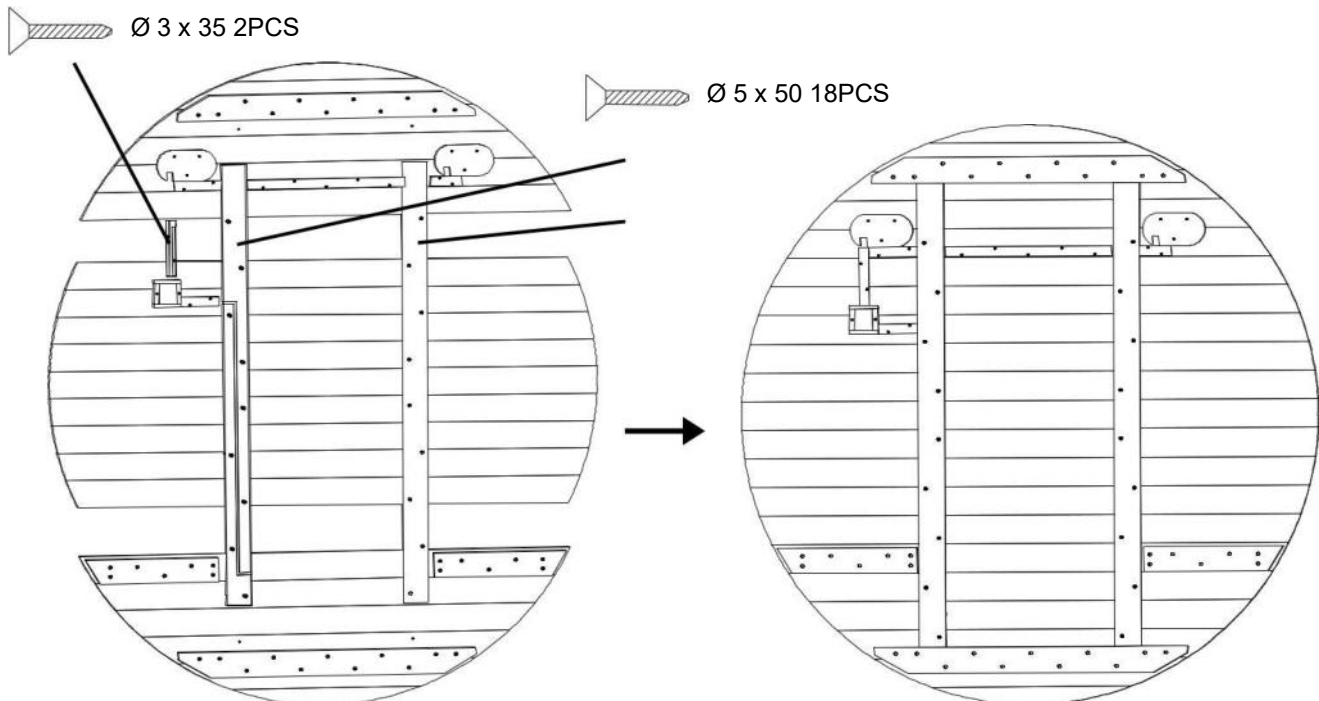
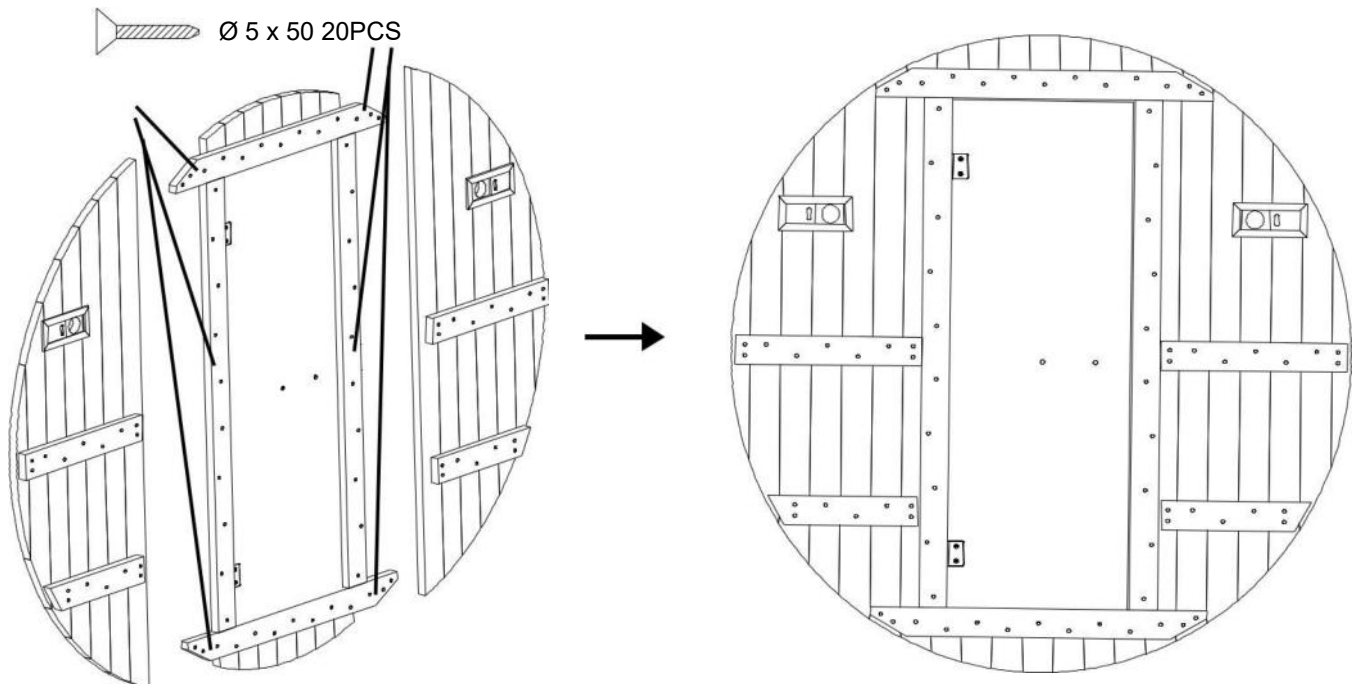

Die Vorder- und Rückwand müssen zunächst als Ganzes zusammengebaut werden.
Die Vorderseite ist links und rechts in drei Teile unterteilt, die Rückseite ist oben und unten in drei Teile unterteilt.

Montageanleitung

Ø 5 x 50 2PCS

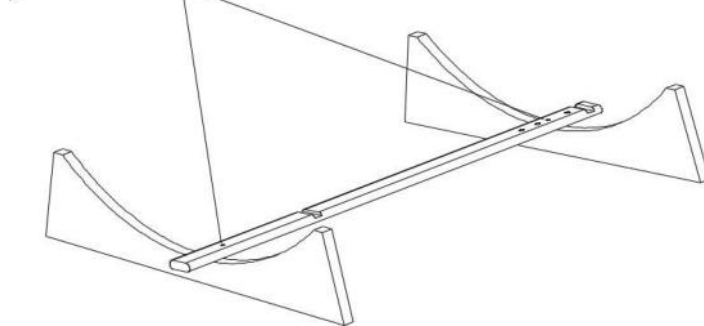

Basis

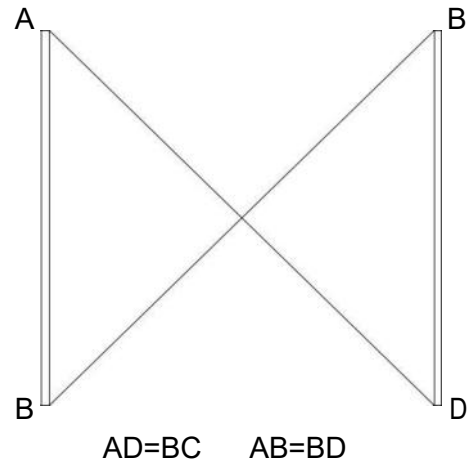

Jede Lamelle ist nummeriert und beschriftet.

Die linke Seite ist L01 L02 L03..... L38 von unten nach oben;

Die rechte Seite ist R01 R02 R03..... R38 von unten nach oben.

Montageanleitung

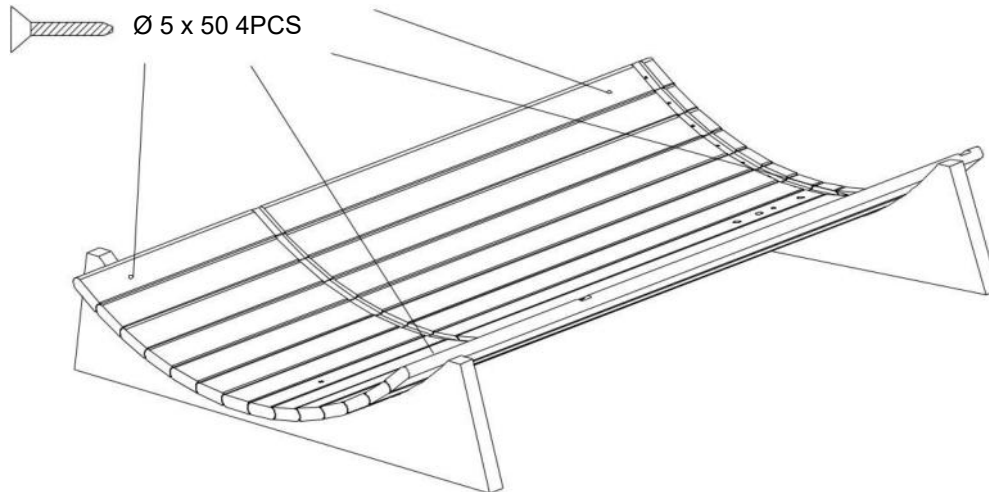

Untere Lamelle

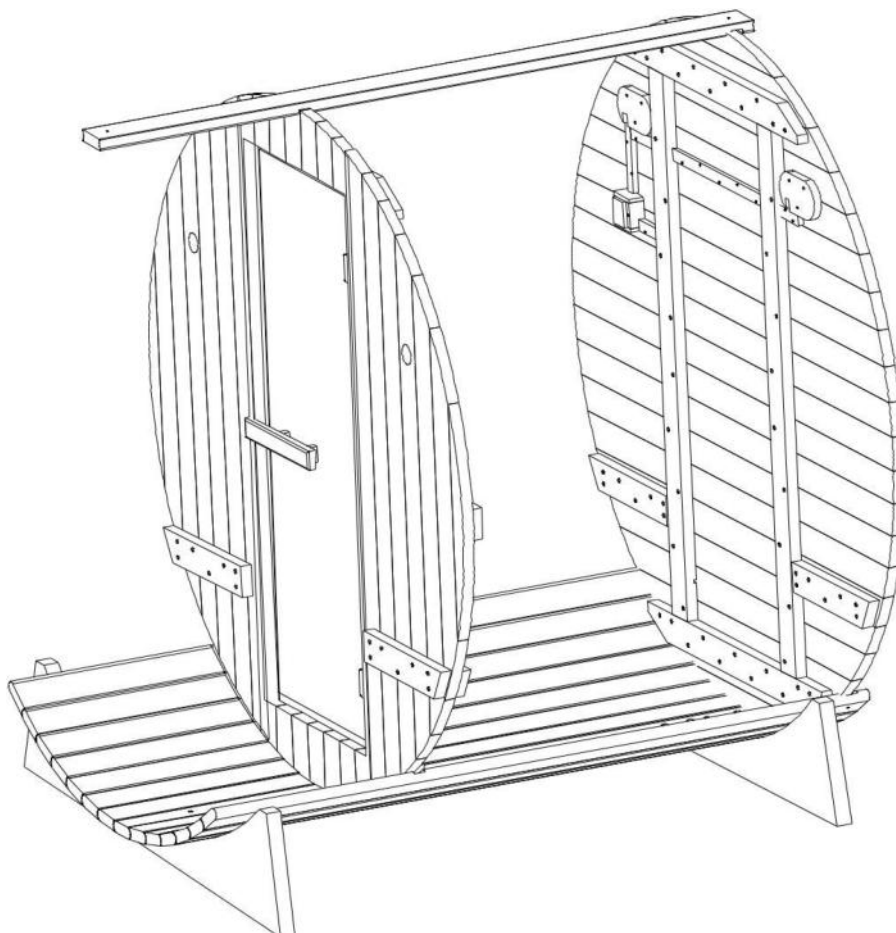

Die obere Lamelle wird während des Einbaus vorübergehend als feste Schutzmaßnahme installiert.

Montageanleitung

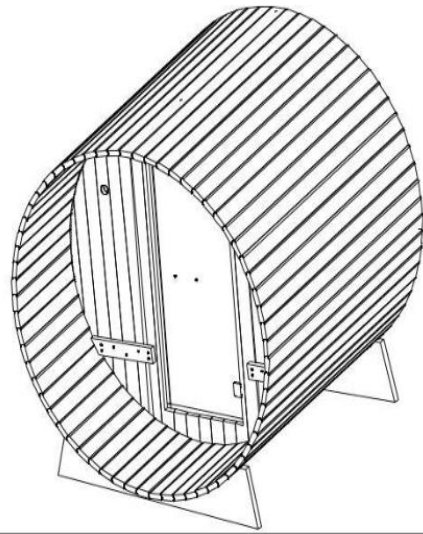
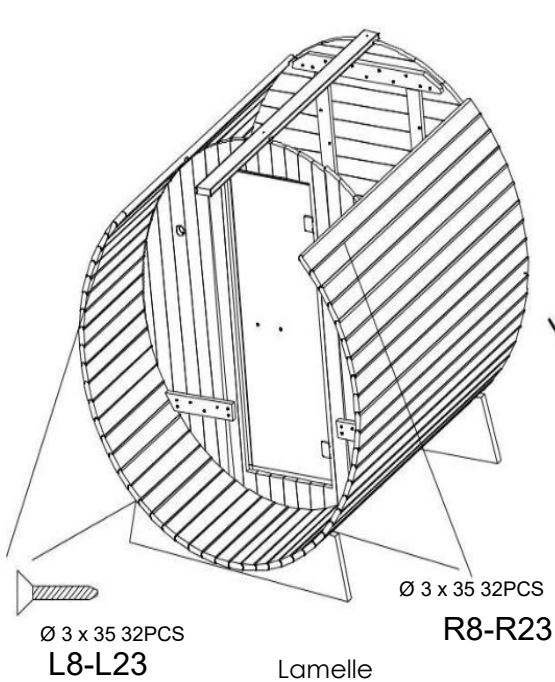

1. Die Lamellen des Fasskörpers müssen bei der Installation dicht aneinander liegen, was der oberen Installation und der Dichtheit förderlich ist.
2. Schrauben (M3*35 64PCS) werden verwendet, um die Lamellen L8-L23 und R8-R23 zu befestigen, die oberen Lamellen werden fest angebracht, nachdem sie einen Kreis gebildet haben, der Lauf ist mit rostfreien Stahlbändern befestigt.

Je nach den tatsächlichen Installationsanforderungen, ein oder zwei dünne Platten in der Mitte können nach Lösen der Schrauben entfernt werden.

Dünne Platten

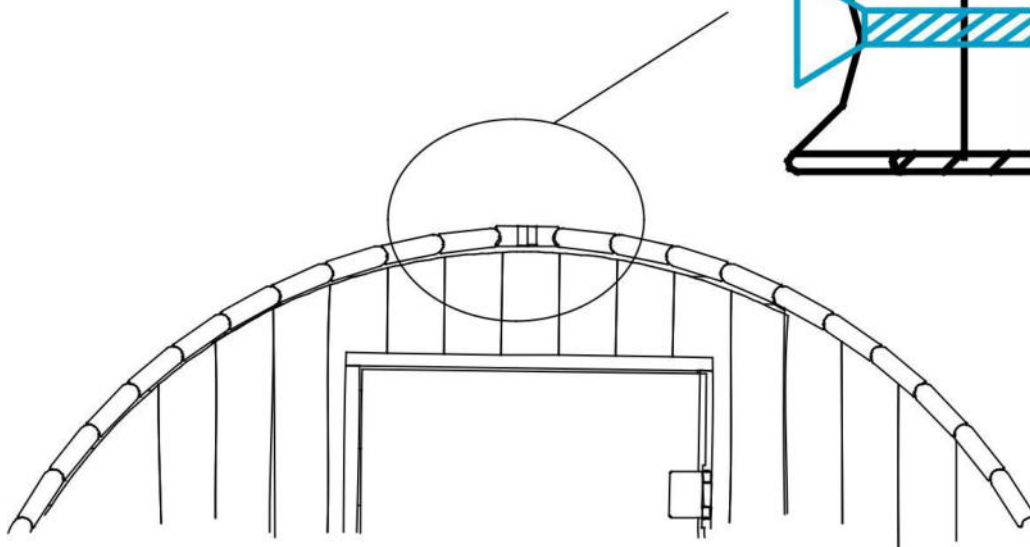
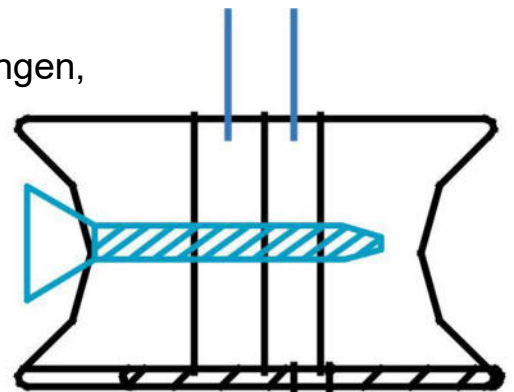

Montageanleitung

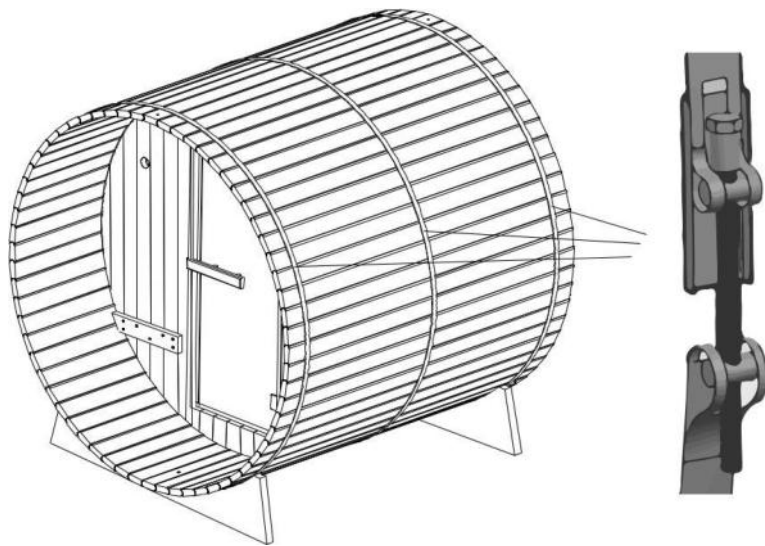

Bänder aus rostfreiem Stahl

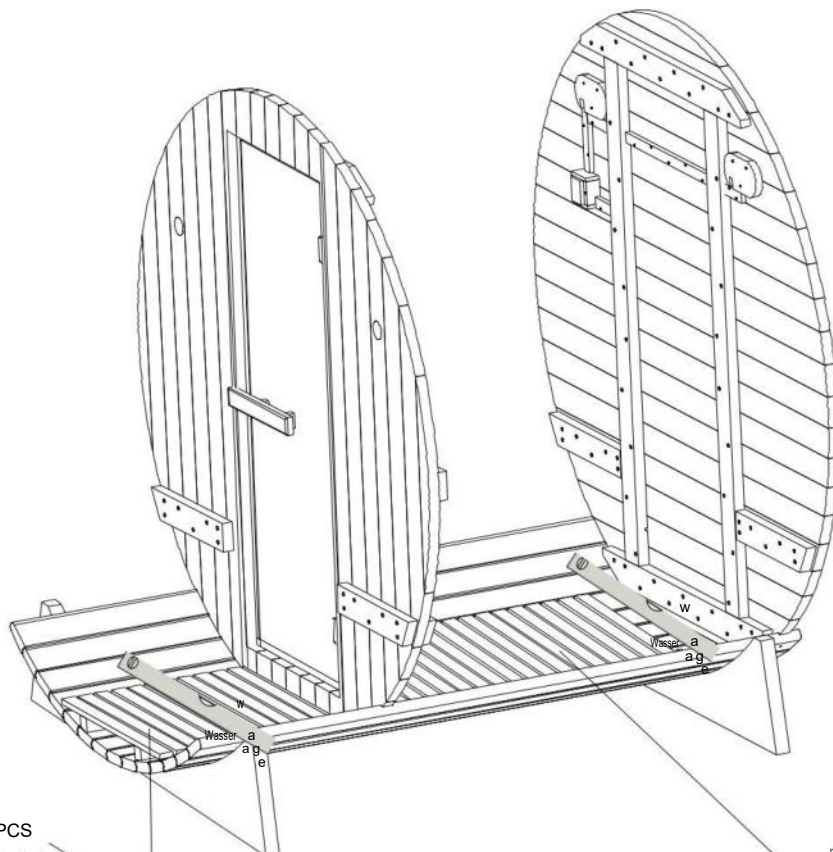

Ø 4 x 50 4PCS

Ø 4 x 50 4PCS

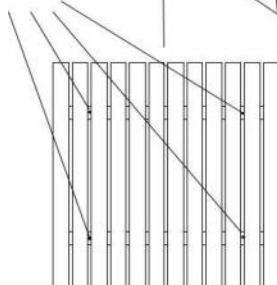

Fußstütze

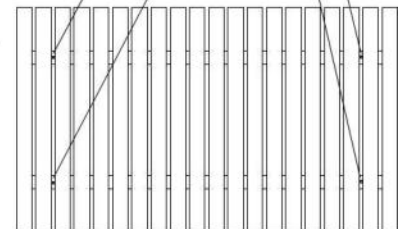

Montageanleitung

Die Halterung der inneren und äußeren Sitzplatten ist vorinstalliert.
 Die äußere Grundplatte benötigt einen weiteren Tragrahmen, und der Tragrahmen fixiert die Schrauben an den Lamellen.
 Die innere Grundplatte benötigt keinen weiteren Stützrahmen.
 Die Sitzplattenverriegelungsschrauben müssen an der Stützseite der vorderen und hinteren Platte befestigt werden.

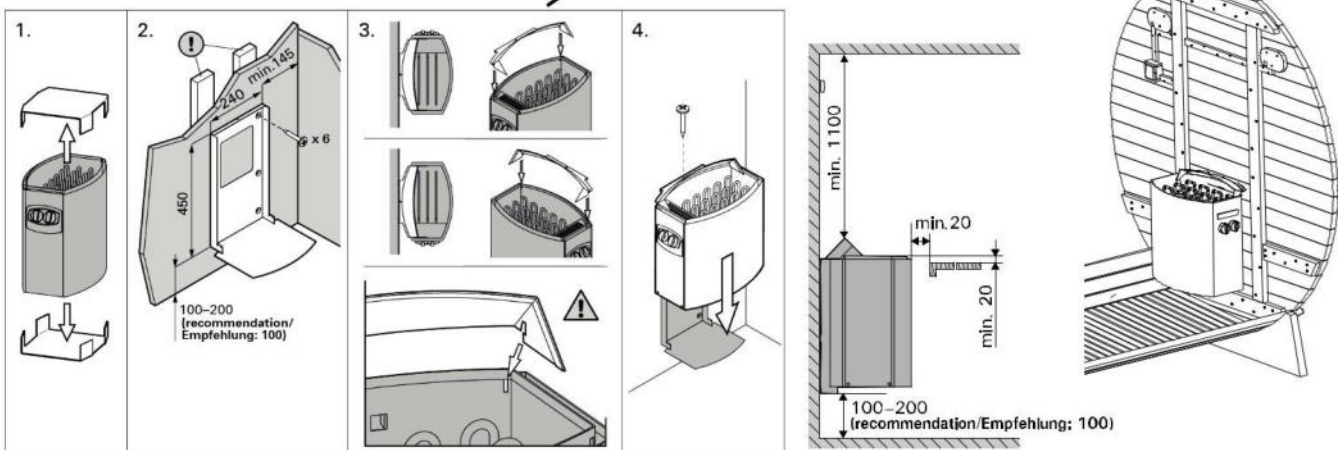
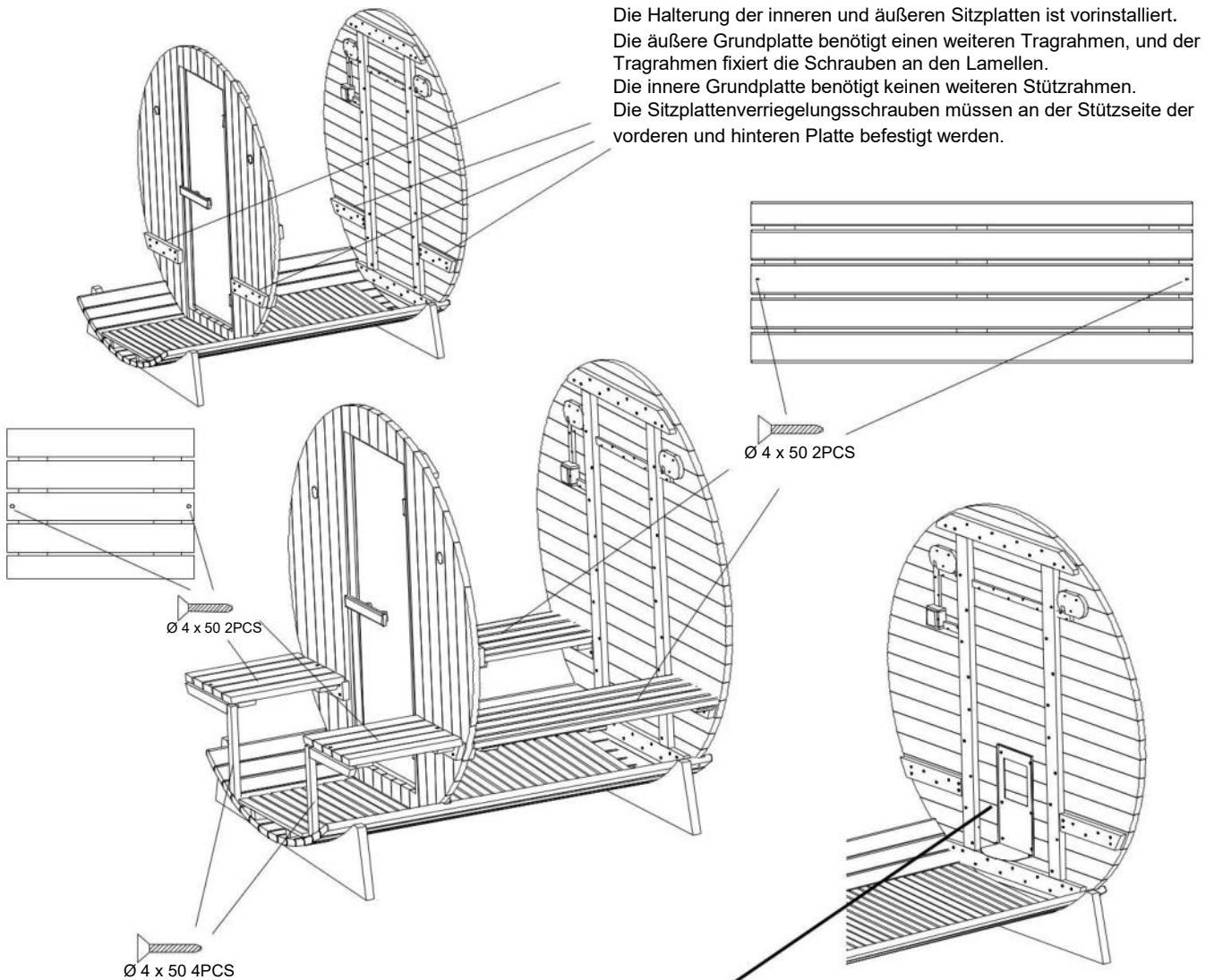

Bei der Installation einer Sauna muss zuerst die Wandhalterung des Ofenrahmens montiert werden, und dann wird der Ofen aufgehängt. Genaue Informationen entnehmen Sie bitte dem Diagramm. Ausführliche Informationen finden Sie in der mit dem Saunaofen gelieferten Anleitung.

Die Drähte der Leuchte sollten an den Kabelsockel des Saunaofens angeschlossen und über den Saunaofen mit Strom versorgt werden.

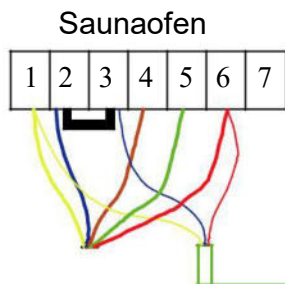
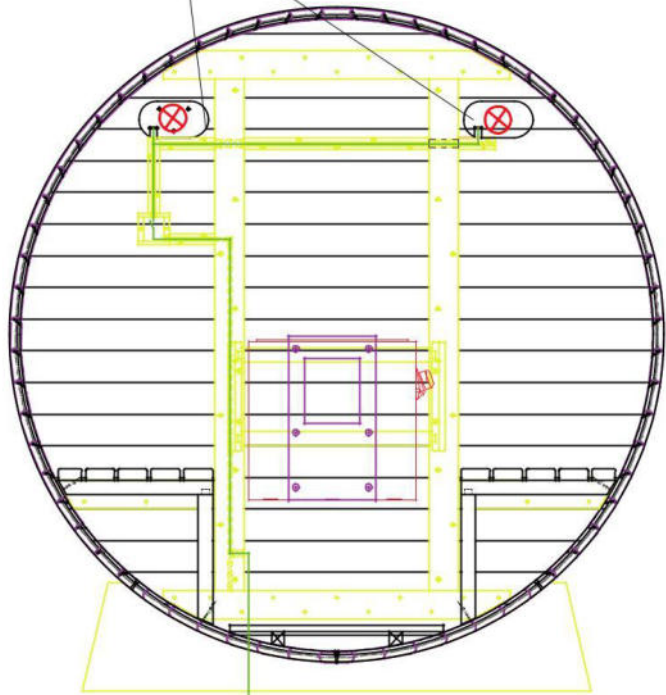
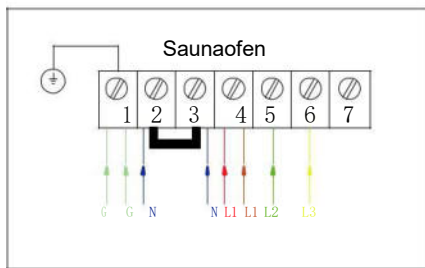
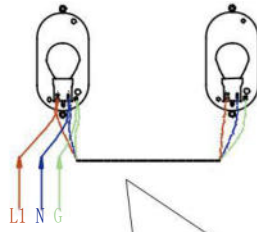

Lampenleitung (3*0,75mm²)

Kabel (5*2,5mm²)

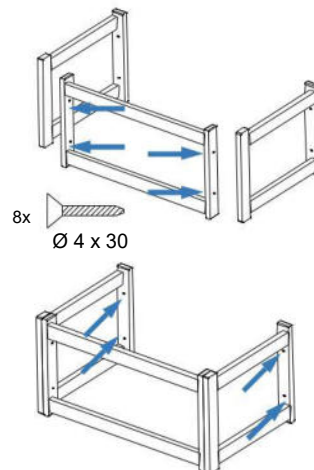
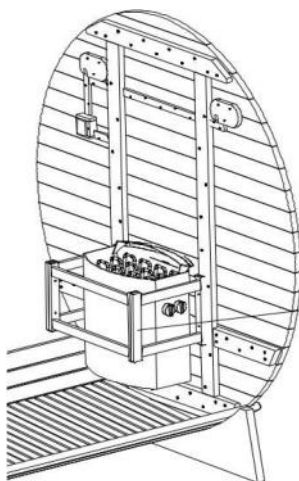

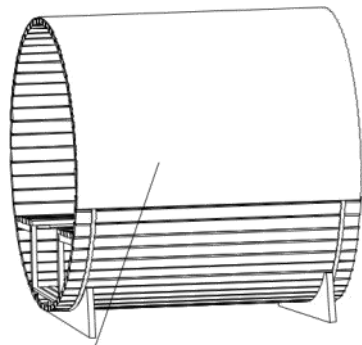

Wasserdichtes Gewebe

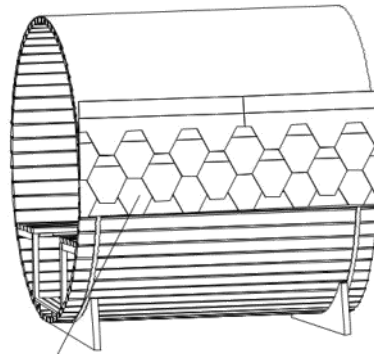

Asphaltschindel

Ø 4 x 12 200PCS

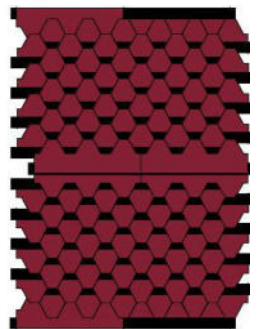
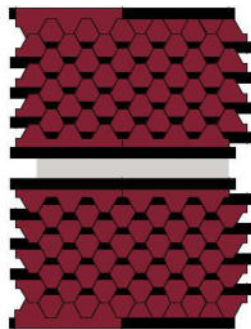
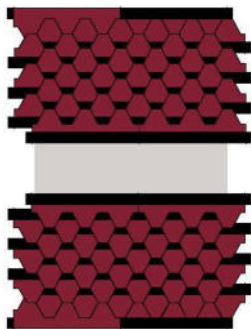
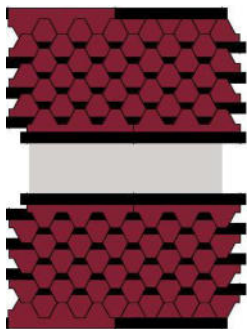
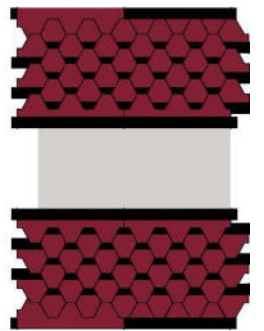
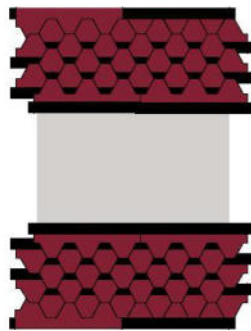
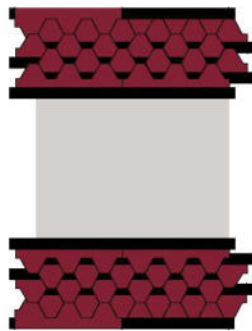
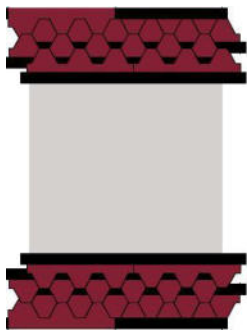
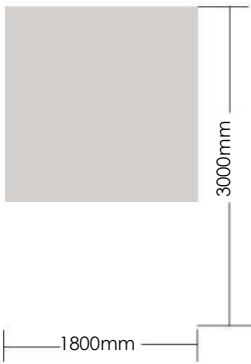

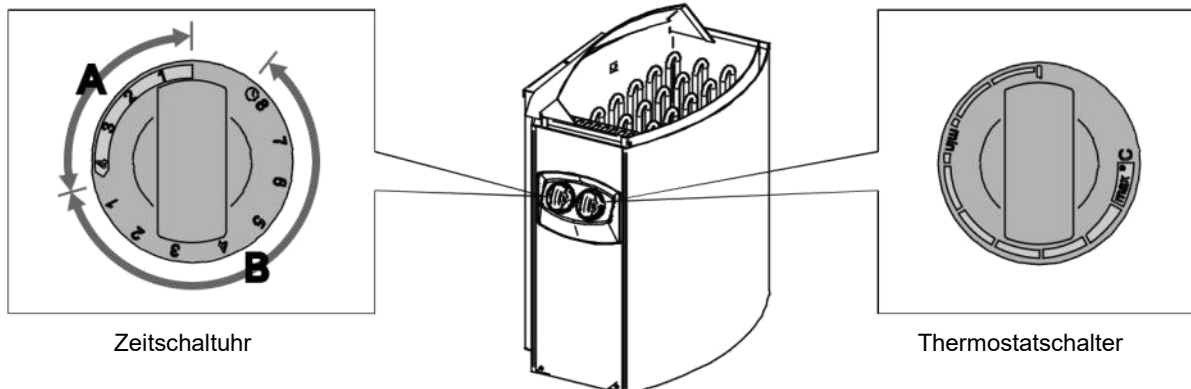

1. Heizgerät An



Schalten Sie den Timer-Schalter auf "on".
(Abschnitt A in Abbildung 2, 0-4 Stunden).
Die Heizung beginnt sofort zu heizen.

2. Voreinstellung Zeit (zeitgesteuertes Einschalten)



Stellen Sie den Schalter der Zeitschaltuhr auf den Abschnitt "Voreinstellung" (Abschnitt B in Abbildung 2, 0-8 Stunden). Das Heizgerät beginnt zu heizen, wenn der Timer den Schalter wieder auf "on" gestellt hat. Danach wird die Heizung etwa vier Stunden lang eingeschaltet sein.

Ausführliche Informationen über den spezifischen Gebrauch und die Vorsichtsmaßnahmen des Saunaofens finden Sie in der mit dem Saunaofen gelieferten Bedienungsanleitung.

Wartung

Schutz von Holz

Bürsten Sie jede äußere Fasslatte und tragen Sie nach der vollständigen Montage ein Schutzmittel auf, um das Holz zu schützen.

Der Schutzmittel musste entsprechend den Empfehlungen des verwendeten Produkts erneuert werden

WICHTIG!

Trennen Sie das Stromversorgungskabel der Kabine, bevor Sie irgendwelche Arbeiten durchführen.

Ermittelte Probleme	Mögliche Gründe	Lösungen
Der Elektroherd wird nicht warm.	Das Stromversorgungskabel ist nicht angeschlossen.	Überprüfen Sie den Anschluss des Stromversorgungskabels.
	Die allgemeine Stromversorgung ist unterbrochen.	Prüfen Sie, ob die Schalttafel und die Steckdose funktionieren.
	Der Herd ist gegen Überhitzung geschützt.	Siehe Handbuch des Elektroherds.
Saunaleuchte nicht mehr vorhanden	Lichtkabel nicht vollständig angeschlossen.	Stecken Sie das Kabel ein.
	Das Licht ist defekt.	Wenden Sie sich an Ihren Händler.

Serviceleistungen

1. Schalten Sie Ihre Sauna aus.
2. Verwenden Sie einen Staubsauger, um den Staub aus den Ritzen der Holzverkleidung zu entfernen.
3. Reinigen Sie die Kabine mit einem feuchten Baumwolltuch und verwenden Sie gegebenenfalls eine kleine Menge Seife. Spülen Sie mit einem feuchten Tuch nach.
4. Reinigen Sie das Glas mit einem Fenster-/Glasreiniger und einem weichen Tuch.
5. Pflegen Sie die Außenseite der Sauna alle 2 Jahre mit einem geeigneten Produkt.

WICHTIG!

Das Holz sollte nur an der Außenseite der Sauna mit einem Schutzmittel behandelt werden.

In der Sauna darf keine Behandlung durchgeführt werden.

Verwenden Sie kein Benzol, Alkohol, chemische Mittel oder starke Reinigungsmittel für die Sauna, da chemische Produkte das Holz beschädigen können. Besprühen Sie Ihre Sauna nicht mit Wasser.

Bitte lesen Sie die mit dem Saunaofen gelieferte Anleitung für die Installation und Verwendung des Ofens.

Das Heizgerät darf nur von einem autorisierten Elektrofachmann nach den geltenden Vorschriften an das Stromnetz angeschlossen werden.

BC45, BC60, BC80 BC45E, BC60E, BC80E, BC90E

EN

Instructions for Installation and Use of Electric Sauna Heater

DE

Gebrauchs- und Montageanleitung des Elektrosaunaofens



BC



BC-E

These instructions for installation and use are intended for the owner or the person in charge of the sauna, as well as for the electrician in charge of the electrical installation of the heater. After completing the installation, the person in charge of the installation should give these instructions to the owner of the sauna or to the person in charge of its operation. Please read the instructions for use carefully before using the heater.

The heater is designed for the heating of a sauna room to bathing temperature. It is not to be used for any other purpose.

Congratulations on your choice!

Guarantee:

- The guarantee period for heaters and control equipment used in saunas by families is two (2) years.
- The guarantee period for heaters and control equipment used in saunas by building residents is one (1) year.
- The guarantee does not cover any faults resulting from failure to comply with installation, use or maintenance instructions.
- The guarantee does not cover any faults resulting from the use of stones not recommended by the heater manufacturer.

CONTENTS

1. INSTRUCTIONS FOR USE	3
1.1. Piling of the Sauna Stones.....	3
1.1.1. Maintenance	3
1.2. Heating of the Sauna.....	4
1.3. Using the Heater	4
1.3.1. Heater On	4
1.3.2. Pre-setting Time (timed switch-on)	4
1.3.3. Heater Off.....	5
1.3.4. Setting the Temperature	5
1.4. Throwing Water on Heated Stones	5
1.5. Instructions for Bathing	6
1.6. Warnings	6
1.7. Troubleshooting	6
2. SAUNA ROOM	8
2.1. Sauna Room Structure	8
2.1.1. Blackening of the sauna walls.....	8
2.2. Sauna Room Ventilation.....	9
2.3. Heater Output.....	9
2.4. Sauna Room Hygiene.....	9
3. INSTRUCTIONS FOR INSTALLATION	10
3.1. Before Installation	10
3.2. Fastening the Heater on a Wall	11
3.3. Electrical Connections.....	12
3.3.1. Electric Heater Insulation Resistance.....	12
3.4. Installation of the Control Unit and Sensors (BC-E) ..	13
3.5. Resetting the Overheat Protector.....	13
4. SPARE PARTS	15

Diese Montage- und Gebrauchsanleitung richtet sich an den Besitzer der Sauna oder an die für die Pflege der Sauna verantwortliche Person, sowie an den für die Montage des Saunaofens zuständigen Elektromonteur. Wenn der Saunaofen montiert ist, wird diese Montage- und Gebrauchsanleitung an den Besitzer der Sauna oder die für die Pflege der Sauna verantwortliche Person übergeben. Lesen Sie vor Inbetriebnahme des Ofens die Bedienungsanleitung sorgfältig durch.

Der Ofen dient zum Erwärmen von Saunakabinen auf Saunatemperatur. Die Verwendung zu anderen Zwecken ist verboten.

Wir beglückwünschen Sie zu Ihrer guten Wahl!

Garantie:

- Die Garantiezeit für in Familiensaunen verwendete Saunaöfen und Steuergeräte beträgt zwei (2) Jahre.
- Die Garantiezeit für Saunaöfen und Steuergeräte, die in öffentlichen Saunen in Privatgebäuden verwendet werden, beträgt ein (1) Jahr.
- Die Garantie deckt keine Defekte ab, die durch fehlerhafte Installation und Verwendung oder Missachtung der Wartungsanweisungen entstanden sind.
- Die Garantie kommt nicht für Schäden auf, die durch Verwendung anderer als vom Werk empfohlener Saunaofensteine entstehen.

INHALT

1. BEDIENUNGSANLEITUNG	3
1.1. Aufschichten der Saunaofensteine.....	3
1.1.1. Wartung	3
1.2. Erhitzen der Saunakabine	4
1.3. Benutzung des Ofens.....	4
1.3.1. Ofen ein	4
1.3.2. Vorwahlzeit (zeitgesteuertes Einschalten)	4
1.3.3. Ofen aus.....	5
1.3.4. Einstellen der Temperatur.....	5
1.4. Aufguss	5
1.5. Anleitungen zum Saunen.....	6
1.6. Warnungen.....	6
1.7. Störungen	6
2. SAUNAKABINE	8
2.1. Struktur der Saunakabine	8
2.1.1. Schwärzung der Saunawände.....	8
2.2. Belüftung der Saunakabine	9
2.3. Leistungsabgabe des Ofens	9
2.4. Hygiene der Saunakabine	9
3. INSTALLATIONSANLEITUNG	10
3.1. Vor der Montage	10
3.2. Befestigung des Saunaofens an der Wand	11
3.3. Elektroanschlüsse.....	12
3.3.1. Isolationswiderstand des Elektrosaunaofens... ..	12
3.4. Anschluß des Steuergerätes und der Fühler (BC-E)..	13
3.5. Zurückstellen des Überhitzungsschutzes.....	13
4. ERSATZTEILE	15

1. INSTRUCTIONS FOR USE

1.1. Piling of the Sauna Stones

The piling of the sauna stones has a great effect on the functioning of the heater (figure 1).

Important information on sauna stones:

- The stones should be 5–10 cm in diameter.
- Use solely angular split-face sauna stones that are intended for use in a heater. Peridotite, olivine-dolerite and olivine are suitable stone types.
- **Neither light, porous ceramic "stones" nor soft soapstones should be used in the heater. They do not absorb enough heat when warmed up. This can result in damage in heating elements.**
- Wash off dust from the stones before piling them into the heater.

Please note when placing the stones:

- Do not drop stones into the heater.
- Do not wedge stones between the heating elements.
- Place the stones sparsely to ensure that air can circulate between them.
- Pile the stones so that they support each other instead of lying their weight on the heating elements.
- Do not form a high pile of stones on top of the heater.
- No such objects or devices should be placed inside the heater stone space or near the heater that could change the amount or direction of the air flowing through the heater.

1. BEDIENUNGSANLEITUNG

1.1. Aufschichten der Saunaofensteine

Die Schichtung der Ofensteine hat eine große Auswirkung auf die Effizienz des Ofens (Abb. 1).

Wichtige Informationen zu Saunaofensteinen:

- Die Steine sollten einen Durchmesser von 5–10 cm haben.
- Verwenden Sie nur spitze Saunasteine mit rauer Oberfläche, die für die Verwendung in Saunaöfen vorgesehen sind. Geeignete Gesteinsarten sind Peridotit, Olivin-Dolerit und Olivin.
- **Im Saunaofen sollten weder leichte poröse „Steine“ aus Keramik noch weiche Specksteine verwendet werden. Sie absorbieren beim Erhitzen nicht genügend Wärme, was zu einer Beschädigung der Heizelemente führen kann.**
- Die Steine sollten vor dem Aufschichten von Steinstaub befreit werden.

Beachten Sie beim Platzieren der Steine Folgendes:

- Lassen Sie die Steine nicht einfach in den Ofen fallen.
- Vermeiden Sie ein Verkeilen von Steinen zwischen den Heizelementen.
- Schichten Sie die Steine in lockerer Anordnung, so dass Luft zwischen ihnen hindurchströmen kann.
- Schichten Sie die Steine so aufeinander, dass sie nicht gegen die Heizelemente drücken.
- Schichten Sie die Steine oben auf dem Ofen nicht zu einem hohen Stapel auf.
- In der Steinkammer oder in der Nähe des Saunaofens dürfen sich keine Gegenstände oder Geräte befinden, die die Menge oder die Richtung des durch den Saunaofen führenden Luftstroms ändern.

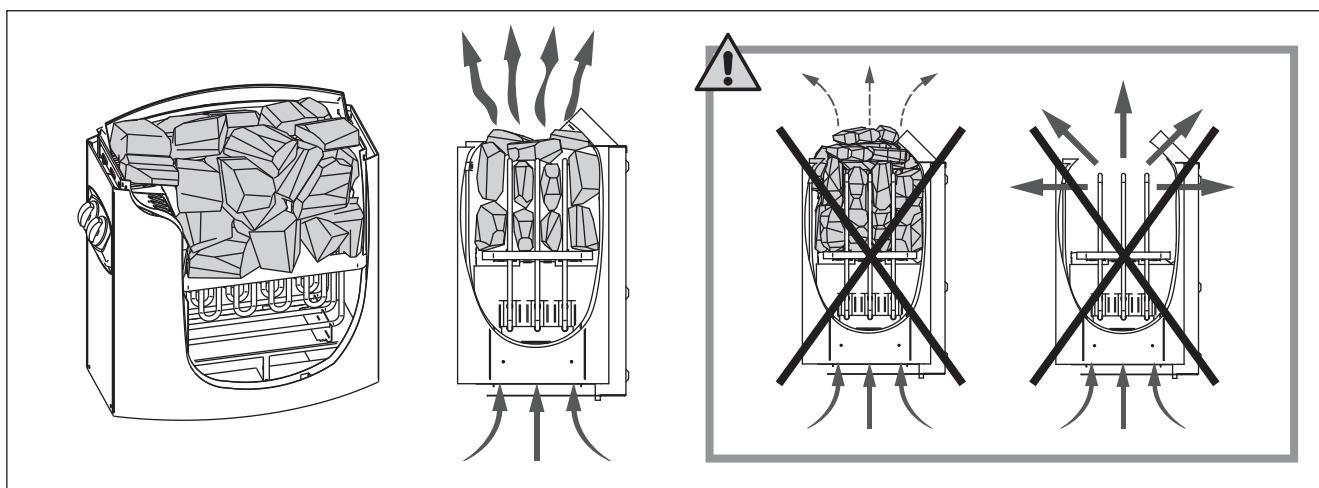

Figure 1. Piling of the sauna stones
Abbildung 1. Aufschichtung der Saunaofensteine

1.1.1. Maintenance

Due to large variation in temperature, the sauna stones disintegrate in use. Rearrange the stones at least once a year or even more often if the sauna is in frequent use. At the same time, remove any pieces of stones from the bottom of the heater and replace any disintegrated stones with new ones. By doing this, the heating capability of the heater stays optimal and the risk of overheating is avoided.

1.1.1. Wartung

Aufgrund der großen Wärmeänderungen werden die Saunasteine spröde und brüchig. Die Steine sollten mindestens einmal jährlich neu aufgeschichtet werden, bei regelmäßigem Gebrauch öfter. Bei dieser Gelegenheit entfernen Sie bitte auch Staub und Gesteinssplitter aus dem unteren Teil des Saunaofens und ersetzen beschädigte Steine. Hierdurch bleibt die Heizleistung des Ofens optimal, und das Risiko der Überhitzung wird vermieden.

1.2. Heating of the Sauna

When operating the heater for the first time, both the heater and the stones emit smell. To remove the smell, the sauna room needs to be efficiently ventilated.

If the heater output is suitable for the sauna room, it will take about an hour for a properly insulated sauna to reach the required bathing temperature (▷ 2.3.). The sauna stones normally reach the bathing temperature at the same time as the sauna room. A suitable temperature for the sauna room is about 65–80 °C.

1.3. Using the Heater

Before switching the heater on always check that there isn't anything on top of the heater or inside the given safety distance. ▷ 1.6.

- Heater models BC45, BC60 and BC80 are equipped with a timer and a thermostat. The timer is for setting the on-time for the heater and the thermostat is for setting a suitable temperature. ▷ 1.3.1.–1.3.4.
- Heater models BC45E, BC60E, BC80E and BC90E are controlled from a separate control unit. See the instructions for use of the selected control unit model.

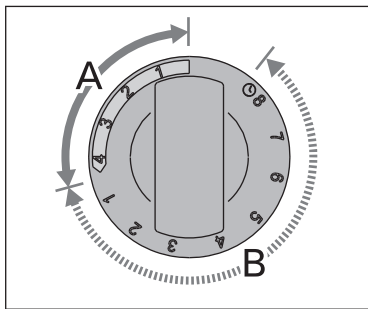

Figure 2. Timer switch
Abbildung 2. Schalter der Zeitschaltuhr

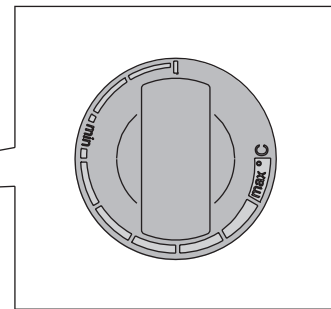
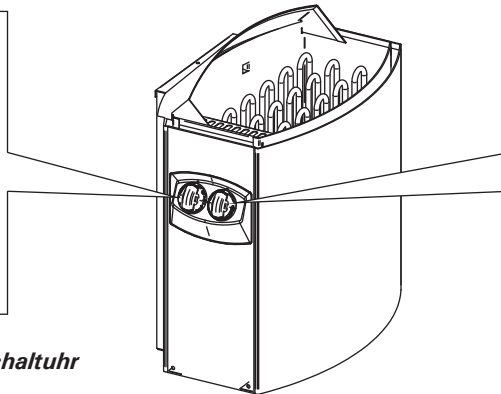

Figure 3. Thermostat switch
Abbildung 3. Thermostatschalter

1.3.1. Heater On



Turn the timer switch to the "on" section (section A in figure 2, 0–4 hours). The heater starts heating immediately.

1.3.2. Pre-setting Time (timed switch-on)



Turn the timer switch to the "pre-setting" section (section B in figure 2, 0–8 hours). The heater starts heating when the timer has turned the switch back to the "on" section. After this, the heater will be on for about four hours.

Example: You want to go walking for three hours and have a sauna bath after that. Turn the timer switch to the "pre-setting" section at number 2.

The timer starts. After two hours, the heater starts heating. Because it takes about one hour for the sauna to be heated, it will be ready for bathing after about three hours, that is, when you come back from your walk.

1.2. Erhitzen der Saunakabine

Beim ersten Erwärmen sondern sich von Saunaofen und Steinen Gerüche ab. Um diese zu beseitigen, muss die Saunakabine gründlich gelüftet werden.

Bei einer für die Saunakabine angemessenen Ofenleistung ist eine isolierte Sauna innerhalb von einer Stunde auf die erforderliche Saunatemperatur aufgeheizt (▷ 2.3.). Die Saunaofensteine erwärmen sich gewöhnlicherweise in derselben Zeit auf Aufgusstemperatur wie die Saunakabine. Die passende Temperatur in der Saunakabine beträgt etwa 65 bis 80 °C.

1.3. Benutzung des Ofens

Bitte überprüfen Sie, bevor Sie den Ofen anschalten, dass keine Gegenstände auf dem Ofen oder in unmittelbarer Nähe des Ofens liegen. ▷ 1.6.

- Die Ofenmodelle BC45, BC60 und BC80 sind mit einer Zeitschaltuhr und einem Thermostat ausgestattet. Die Zeitschaltuhr regelt die Einschaltzeit des Ofens und das Thermostat die Temperatur. ▷ 1.3.1.–1.3.4.
- Die Ofenmodelle BC45E, BC60E, BC80E und BC90E werden mit einem separaten Steuergerät bedient. Beachten Sie die mitgelieferte Bedienungsanleitung der Steuerung.

1.3.1. Ofen ein

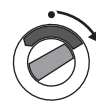

Stellen Sie den Schalter der Zeitschaltuhr in den Abschnitt "ein" (Abschnitt A in Abb. 2, 0–4 Stunden). Der Ofen beginnt sofort zu heizen.

1.3.2. Vorwahlzeit (zeitgesteuertes Einschalten)



Stellen Sie den Schalter der Zeitschaltuhr in den Abschnitt "Vorwahl" (Abschnitt B in Abb. 2, 0–8 Stunden). Der Ofen beginnt zu heizen, wenn die Zeitschaltuhr den Schalter zurück in den Abschnitt "ein" gedreht hat. Danach bleibt der Ofen etwa vier Stunden lang an.

Beispiel: Sie möchten drei Stunden lang spazieren gehen und danach ein Saunabad nehmen. Stellen Sie den Schalter der Zeitschaltuhr in den Abschnitt "Vorwahl" auf Nummer 2.

Die Zeitschaltuhr beginnt zu laufen. Nach zwei Stunden beginnt der Ofen zu heizen. Da es etwa eine Stunde dauert, bis die Sauna erhitzt ist, wird sie nach etwa drei Stunden für das Saunabad bereit sein, also dann, wenn Sie von Ihrem Spaziergang zurückkehren.

1.3.3. Heater Off



The heater switches off, when the timer turns the switch back to zero. You can switch the heater off at any time by turning the timer switch to zero yourself.

Switch the heater off after bathing. Sometimes it may be advisable to leave the heater on for a while to let the wooden parts of the sauna dry properly.

NOTE! Always check that the heater has switched off and stopped heating after the timer has turned the switch to zero.

1.3.4. Setting the Temperature

The purpose of the thermostat (figure 3) is to keep the temperature in the sauna room on a desired level. By experimenting, you can find the setting that suits you best.

Begin experimenting at the maximum position. If, during bathing, the temperature rises too high, turn the switch counter-clockwise a little. Note that even a small difference within the maximum section will change the temperature of the sauna considerably.

1.4. Throwing Water on Heated Stones

The air in the sauna room becomes dry when warmed up. Therefore, it is necessary to throw water on the heated stones to reach a suitable level of humidity in the sauna. The effect of heat and steam on people varies – by experimenting, you can find the levels of temperature and humidity that suit you best.

NOTE! The maximum volume of the ladle is 0.2 litres. If an excessive amount of water is poured on the stones, only part of it will evaporate and the rest may splash as boiling hot water on the bathers. Never throw water on the stones when there are people near the heater, because hot steam may burn their skin.

NOTE! The water to be thrown on the heated stones should meet the requirements of clean household water (table 1). Only special aromas designed for sauna water may be used. Follow the instructions given on the package.

1.3.3. Ofen aus



Der Ofen wird ausgeschaltet, wenn die Zeitschaltuhr den Schalter zurück auf null gedreht hat. Sie können den Ofen jederzeit selbst ausschalten, indem Sie den Schalter der Zeitschaltuhr auf null stellen.

Schalten Sie den Ofen nach dem Saunabad aus. Manchmal ist es ratsam, den Ofen noch eine Weile weiter laufen zu lassen, um die Holzteile der Sauna richtig trocknen zu lassen.

ACHTUNG! Vergewissern Sie sich stets, dass der Ofen ausgeschaltet ist und nicht mehr heizt, wenn die Zeitschaltuhr den Schalter zurück auf null gedreht hat.

1.3.4. Einstellen der Temperatur

Zweck des Thermostats (Abb. 3) ist es, die Temperatur in der Saunakabine auf der gewünschten Höhe zu halten. Durch Ausprobieren können Sie ermitteln, welche Einstellung für Sie am besten geeignet ist.

Beginnen Sie mit der höchsten Einstellung. Wenn die Temperatur während des Saunabades zu hoch ansteigt, drehen Sie den Schalter ein Stück gegen den Uhrzeigersinn. Beachten Sie, dass im oberen Temperaturbereich auch kleine Änderungen die Temperatur in der Sauna beträchtlich beeinflussen.

1.4. Aufguss

Die Saunaluft trocknet bei Erwärmung aus, daher sollte zur Erlangung einer angenehmen Luftfeuchtigkeit auf die heißen Steine des Saunaofens Wasser gegossen werden. Die Auswirkungen von Hitze und Dampf sind von Mensch zu Mensch unterschiedlich – durch Ausprobieren finden Sie die Temperatur- und Luftfeuchtigkeitswerte, die für Sie am besten geeignet sind.

ACHTUNG! Die Kapazität der Saunakelle sollte höchstens 0,2 l betragen. Auf die Steine sollten keine größeren Wassermengen auf einmal gegossen werden, da beim Verdampfen sonst kochend heißes Wasser auf die Badenden spritzen könnte. Achten Sie auch darauf, daß Sie kein Wasser auf die Steine gießen, wenn sich jemand in deren Nähe befindet. Der heiße Dampf könnte Brandwunden verursachen.

ACHTUNG! Als Aufgusswasser sollte nur Wasser verwendet werden, das die Qualitätsvorschriften für Haushaltswasser erfüllt (Tabelle 1). Im Aufgusswasser dürfen nur für diesen Zweck ausgewiesene Duftstoffe verwendet werden. Befolgen Sie die Anweisungen auf der Packung.

Water property Wassereigenschaft	Effect Wirkung	Recommendation Empfehlung
Humus concentration Humusgehalt	Colour, taste, precipitates Farbe, Geschmack, Ablagerungen	< 12 mg/l
Iron concentration Eisengehalt	Colour, odour, taste, precipitates Farbe, Geruch, Geschmack, Ablagerungen	< 0,2 mg/l
Hardness: most important substances are manganese (Mn) and lime, i.e. calcium (Ca). Wasserhärte: Die wichtigsten Stoffe sind Mangan (Mn) und Kalk, d.h. Kalzium (Ca).	Precipitates Ablagerungen	Mn: < 0,05 mg/l Ca: < 100 mg/l
Chlorinated water Gechlortes Wasser	Health risk Gesundheitsschädlich	Forbidden to use Darf nicht verwendet werden
Seawater Salzwasser	Rapid corrosion Rasche Korrosion	Forbidden to use Darf nicht verwendet werden

Table 1. Water quality requirements
Tabelle 1. Anforderungen an die Wasserqualität

1.5. Instructions for Bathing

- Begin by washing yourself.
- Stay in the sauna for as long as you feel comfortable.
- Forget all your troubles and relax.
- According to established sauna conventions, you must not disturb other bathers by speaking in a loud voice.
- Do not force other bathers from the sauna by throwing excessive amounts of water on the stones.
- Cool your skin down as necessary. If you are in good health, you can have a swim if a swimming place or pool is available.
- Wash yourself after bathing.
- Rest for a while and let your pulse go back to normal. Have a drink of fresh water or a soft drink to bring your fluid balance back to normal.

1.6. Warnings

- **Staying in the hot sauna for long periods of time makes the body temperature rise, which may be dangerous.**
- **Keep away from the heater when it is hot. The stones and outer surface of the heater may burn your skin.**
- **Keep children away from the heater.**
- **Do not let young, handicapped or ill people bathe in the sauna on their own.**
- **Consult your doctor about any health-related limitations to bathing.**
- **Consult your child welfare clinic about taking little babies to the sauna.**
- **Be very careful when moving in the sauna, as the platform and floors may be slippery.**
- **Never go to a hot sauna if you have taken alcohol, strong medicines or narcotics.**
- **Never sleep in a hot sauna.**
- **Sea air and a humid climate may corrode the metal surfaces of the heater.**
- **Do not hang clothes to dry in the sauna, as this may cause a risk of fire. Excessive moisture content may also cause damage to the electrical equipment.**

1.7. Troubleshooting

Note! All service operations must be done by professional maintenance personnel.

The heater does not heat.

- Check that the fuses to the heater are in good condition.
- Check that the connection cable is connected (▷ 3.3.).
- Turn the timer switch to the "on" section (▷ 1.3.1.).
- Turn the thermostat to a higher setting (▷ 1.3.4.).
- Check that the overheat protector has not gone off. The timer works but the heater does not heat. (▷ 3.5.)

The sauna room heats slowly. The water thrown on the sauna stones cools down the stones quickly.

- Check that the fuses to the heater are in good

1.5. Anleitungen zum Saunen

- Waschen Sie sich vor dem Saunen.
- Bleiben Sie in der Sauna, solange Sie es als angenehm empfinden.
- Vergessen Sie jeglichen Stress, und entspannen Sie sich.
- Zu guten Saunamanieren gehört, daß Sie Rücksicht auf die anderen Badenden nehmen, indem Sie diese nicht mit unnötig lärmigem Benehmen stören.
- Verjagen Sie die anderen auch nicht mit zu vielen Aufgüssen.
- Lassen Sie Ihre erhitzte Haut zwischendurch abkühlen. Falls Sie gesund sind, und die Möglichkeit dazu besteht, gehen Sie auch schwimmen.
- Waschen Sie sich nach dem Saunen.
- Ruhen Sie sich aus, bis Sie sich ausgeglichen fühlen. Trinken Sie klares Wasser oder einen Softdrink, um Ihren Flüssigkeitshaushalt zu stabilisieren.

1.6. Warnungen

- **Ein langer Aufenthalt in einer heißen Sauna führt zum Ansteigen der Körpertemperatur, was gefährlich sein kann.**
- **Achtung vor dem heißen Saunaofen. Die Steine sowie das Gehäuse werden sehr heiß und können die Haut verbrennen.**
- **Halten Sie Kinder vom Ofen fern.**
- **Kinder, Gehbehinderte, Kranke und Schwache dürfen in der Sauna nicht alleingelassen werden.**
- **Gesundheitliche Einschränkungen bezogen auf das Saunen müssen mit dem Arzt besprochen werden.**
- **Über das Saunen von Kleinkindern sollten Sie sich in der Mütterberatungsstelle beraten lassen.**
- **Gehen Sie nicht in die Sauna, wenn Sie unter dem Einfluß von Narkotika (Alkohol, Medikamenten, Drogen usw.) stehen.**
- **Schlafen Sie nie in einer erhitzten Sauna.**
- **Meer- und feuchtes Klima können die Metalloberflächen des Saunaofens rosten lassen.**
- **Benutzen Sie die Sauna wegen der Brandgefahr nicht zum Kleider- oder Wäschetrocknen, außerdem können die Elektrogeräte durch die hohe Feuchtigkeit beschädigt werden.**

1.7. Störungen

Achtung! Alle Wartungsmaßnahmen müssen von qualifiziertem technischem Personal durchgeführt werden.

Der Ofen wärmt nicht.

- Vergewissern Sie sich, dass die Sicherungen des Ofens in gutem Zustand sind.
- Überprüfen Sie, ob das Anschlusskabel eingesteckt ist (▷ 3.3.).
- Stellen Sie den Schalter der Zeitschaltuhr in den Abschnitt "ein" (▷ 1.3.1.).
- Stellen Sie das Thermostat auf eine höhere Einstellung (▷ 1.3.4.).
- Überprüfen Sie, ob der Überhitzungsschutz ausgelöst wurde. Die Zeitschaltuhr läuft, aber der Ofen wärmt nicht. (▷ 3.5.)

Die Saunakabine erhitzt sich zu langsam. Das auf die Saunaofensteine geworfene Wasser kühlt die Steine schnell ab.

condition.

- Check that all heating elements glow when the heater is on.
- Turn the thermostat to a higher setting (▷ 1.3.4.).
- Check that the heater output is sufficient (▷ 2.3.).
- Check the sauna stones (▷ 1.1.). Too tightly piled stones, the settling of stones with time or wrong stone type can hinder the air flow through the heater, which results in reduced heating efficiency.
- Check that the sauna room ventilation has been arranged correctly (▷ 2.2.).

The sauna room heats quickly, but the temperature of the stones remain insufficient.

Water thrown on the stones runs through.

- Turn the thermostat to a lower setting (▷ 1.3.4.).
- Check that the heater output is not too high (▷ 2.3.).
- Check that the sauna room ventilation has been arranged correctly (▷ 2.2.).

The sauna room heats unevenly.

- Check that the heater has been installed in the correct height. The heater heats the sauna best, when it is installed 100 mm from the floor. The maximum installation height is 200 mm. (▷ 3.2.)

Panel or other material near the heater blackens quickly.

- Check that the requirements for safety distances are fulfilled (▷ 3.1.).
- Check the sauna stones (▷ 1.1.). Too tightly piled stones, the settling of stones with time or wrong stone type can hinder the air flow through the heater, which may result in overheating of surrounding materials.
- Also see section 2.1.1.

The heater emits smell.

- See section 1.2.
- The hot heater may emphasize odours mixed in the air that are not, however, caused by the sauna or the heater. Examples: paint, glue, oil, seasoning.

The heater makes noise.

- BC: The timer is a mechanical device and it makes a ticking sound when it is functioning normally. If the timer ticks even when the heater is switched off, check the timer's wiring.
- Occasional bangs are most likely caused by stones cracking due to heat.
- The thermal expansion of heater parts can cause noises when the heater warms up.

- Vergewissern Sie sich, dass die Sicherungen des Ofens in gutem Zustand sind.
- Vergewissern Sie sich, dass bei eingeschaltetem Ofen alle Heizelemente glühen.
- Stellen Sie das Thermostat auf eine höhere Einstellung (▷ 1.3.4.).
- Überprüfen Sie, ob die Ofenleistung ausreichend ist (▷ 2.3.).
- Überprüfen Sie die Saunaofensteine (▷ 1.1.). Eine zu feste Stapelung der Steine, das Absetzen der Steine mit der Zeit und falsche Steinsorten können den Luftstrom durch den Ofen behindern, was zu einer verminderten Heizleistung führt.
- Vergewissern Sie sich, dass die Belüftung der Saunakabine korrekt eingerichtet wurde (▷ 2.2.).

Die Saunakabine erwärmt sich schnell, aber die Temperatur der Steine ist unzureichend. Das auf die Steine geworfene Wasser läuft durch.

- Stellen Sie das Thermostat auf eine niedrigere Einstellung (▷ 1.3.4.).
- Überprüfen Sie, ob die Ofenleistung nicht zu hoch ist (▷ 2.3.).
- Vergewissern Sie sich, dass die Belüftung der Saunakabine korrekt eingerichtet wurde (▷ 2.2.).

Die Saunakabine erhitzt sich ungleichmäßig.

- Vergewissern Sie sich, dass der Ofen in der richtigen Höhe angebracht wurde. Der Ofen kann die Sauna am besten erhitzen, wenn er 100 mm über dem Boden angebracht wird. Die maximale Montagehöhe beträgt 200 mm. (▷ 3.2.)

Panele und andere Materialien neben dem Ofen werden schnell schwarz.

- Überprüfen Sie, ob die Anforderungen für Sicherheitsabstände eingehalten werden (▷ 3.1.).
- Überprüfen Sie die Saunaofensteine (▷ 1.1.). Eine zu feste Stapelung der Steine, das Absetzen der Steine mit der Zeit und falsche Steinsorten können den Luftstrom durch den Ofen behindern, was zu einer Überhitzung der umliegenden Materialien führen kann.
- Siehe auch Abschnitt 2.1.1.

Der Ofen gibt Gerüche ab.

- Siehe Abschnitt 1.2.
- Ein heißer Ofen kann Gerüche in der Luft verstärken, die jedoch nicht durch die Sauna oder den Ofen selbst verursacht wurden. Beispiele: Farbe, Klebstoff, Öl, Würzmittel.

Der Ofen verursacht Geräusche.

- BC: Die Zeitschaltuhr ist ein mechanisches Gerät und verursacht daher ein tickendes Geräusch, wenn sie normal funktioniert. Ertönt das Ticken, obwohl der Ofen nicht eingeschaltet ist, untersuchen Sie die Anschlüsse der Zeitschaltuhr.
- Plötzliche Knall-Geräusche entstehen manchmal durch Steine, die aufgrund der Hitze platzen.
- Die Ausdehnung der Ofenteile wegen der Hitze kann bei der Erwärmung des Ofens Geräusche verursachen.

2. SAUNA ROOM

2.1. Sauna Room Structure

2. SAUNAKABINE

2.1. Struktur der Saunakabine

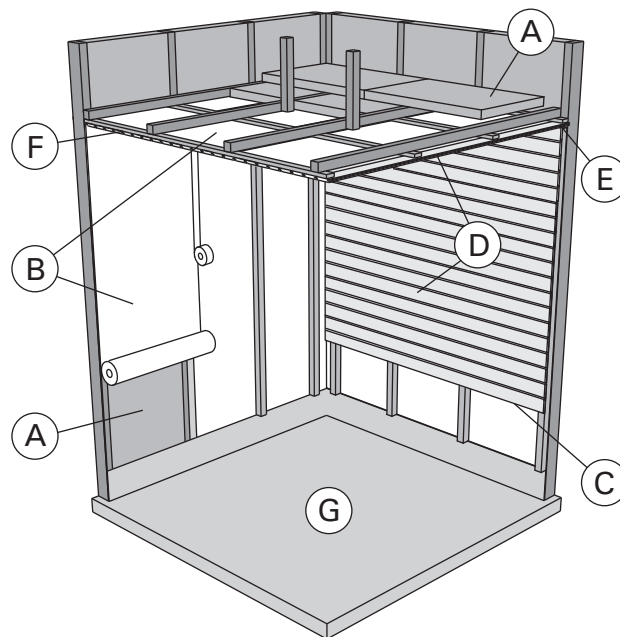

Figure 4.
Abbildung 4.

- A. Insulation wool, thickness 50–100 mm. The sauna room must be insulated carefully so that the heater output can be kept moderately low.
- B. Moisture protection, e.g. aluminium paper. Place the glossy side of the paper towards the sauna. Tape the seams with aluminium tape.
- C. Vent gap of about 10 mm between the moisture protection and panel (recommendation).
- D. Low mass 12–16 mm thick panel board. Before starting the panelling, check the electric wiring and the reinforcements in the walls required by the heater and benches.
- E. Vent gap of about 3 mm between the wall and ceiling panel.
- F. The height of the sauna is usually 2100–2300 mm. The minimum height depends on the heater (see table 2). The space between the upper bench and ceiling should not exceed 1200 mm.
- G. Use floor coverings made of ceramic materials and dark joint grouts. Particles disintegrating from the sauna stones and impurities in the sauna water may stain and/or damage sensitive floor coverings.

NOTE! Check from the fire authorities which parts of the firewall can be insulated. Flues which are in use must not be insulated.

NOTE! Light protective covers which are installed directly to the wall or ceiling may be a fire risk.

2.1.1. Blackening of the sauna walls

It is perfectly normal for the wooden surfaces of the sauna room to blacken in time. The blackening may be accelerated by

- sunlight
- heat from the heater
- protective agents on the walls (protective agents have a poor heat resistance level)
- fine particles disintegrating from the sauna stones which rise with the air flow.

- A. Isolierwolle, Stärke 50–100 mm. Die Saunakabine muss sorgfältig isoliert werden, damit der Ofen nicht zu viel Leistung erbringen muss.
- B. Feuchtigkeitsschutz, z.B. Aluminiumpapier. Die glänzende Seite des Papiers muss zur Sauna zeigen. Nähte mit Aluminiumband abdichten.
- C. Etwa 10 mm Luft zwischen Feuchtigkeitsschutz und Täfelung (Empfehlung).
- D. Leichtes, 12–16 mm starkes Täfelbrett. Vor Beginn der Täfelung elektrische Verkabelung und für Ofen und Bänke benötigte Verstärkungen in den Wänden überprüfen.
- E. Etwa 3 mm Luft zwischen Wand und Deckentäfelung.
- F. Die Höhe der Sauna ist normalerweise 2100–2300 mm. Die Mindesthöhe hängt vom Ofen ab (siehe Tabelle 2). Der Abstand zwischen oberer Bank und Decke sollte höchstens 1200 mm betragen.
- G. Bodenabdeckungen aus Keramik und dunkle Zementschlämme verwenden. Aus den Saunasteinen entweichende Partikel und Verunreinigungen im Wasser können sensible Böden verfärben oder beschädigen.

ACHTUNG! Fragen Sie die Behörden, welcher Teil der feuerfesten Wand isoliert werden kann. Rauchfänge, die benutzt werden, dürfen nicht isoliert werden.

ACHTUNG! Leichte, direkt an Wand oder Decke angebrachte Schutzabdeckungen sind ein Brandrisiko.

2.1.1. Schwärzung der Saunawände

Es ist ganz normal, wenn sich die Holzoberflächen einer Sauna mit der Zeit verfärben. Die Schwärzung wird beschleunigt durch

- Sonnenlicht
- Hitze des Ofens
- Täfelungsschutz an den Wänden (mit geringem Hitzewiderstand)
- Feinpartikel, die aus den zerfallenden Saunasteinen in die Luft entweichen.

2.2. Sauna Room Ventilation

The air in the sauna room should change six times per hour. Figure 5 illustrates different sauna room ventilation options.

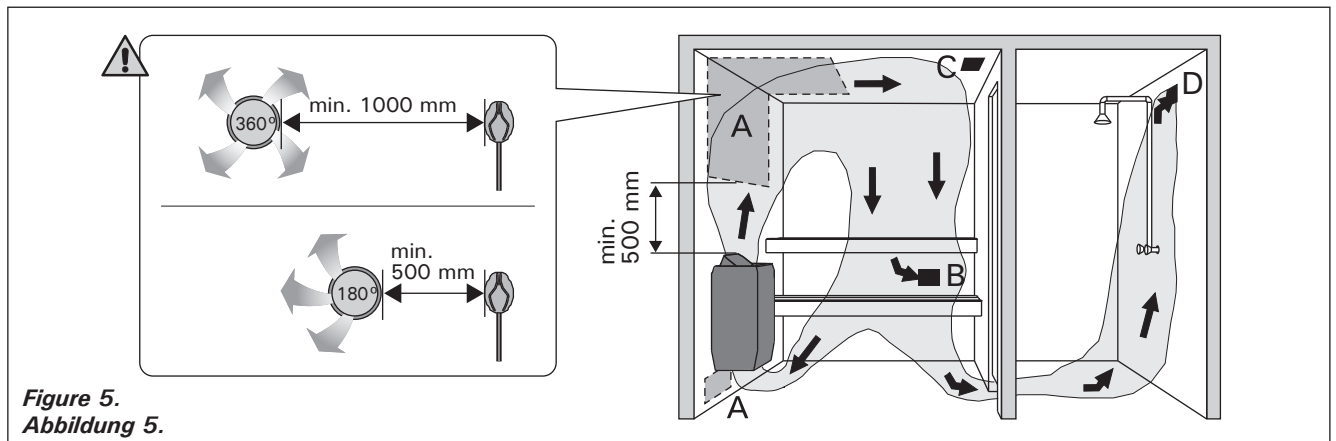

Figure 5.
Abbildung 5.

- A. Supply air vent location. If mechanical exhaust ventilation is used, place the supply air vent above the heater. If gravity exhaust ventilation is used, place the supply air vent below or next to the heater. The diameter of the supply air pipe must be 50–100 mm. **BC-E: Do not place the supply air vent so that the air flow cools the temperature sensor (see the temperature sensor installation instructions in the control unit installation instructions)!**
- B. Exhaust air vent. Place the exhaust air vent near the floor, as far away from the heater as possible. The diameter of the exhaust air pipe should be twice the diameter of the supply air pipe.
- C. Optional vent for drying (closed during heating and bathing). The sauna can also be dried by leaving the door open after bathing.
- D. If the exhaust air vent is in the washroom, the gap underneath the sauna door must be at least 100 mm. Mechanical exhaust ventilation is mandatory.

2.3. Heater Output

When the walls and ceiling are covered with panels and insulation behind the panels is adequate, the heater output is defined according to the volume of the sauna. Non-insulated walls (brick, glass block, glass, concrete, tile, etc.) increase the need for heater output. Add 1,2 m³ to the volume of the sauna for each non-insulated wall square meter. For example, a 10 m³ sauna room with a glass door equals the output requirement of about a 12 m³ sauna room. If the sauna room has log walls, multiply the sauna's volume by 1,5. Choose the correct heater output from table 2.

2.4. Sauna Room Hygiene

Bench towels should be used during bathing to prevent sweat from getting onto the benches.

The benches, walls and floor of the sauna should be washed thoroughly at least every six months. Use a scrubbing brush and sauna detergent.

Wipe dust and dirt from the heater with a damp cloth. Remove lime stains from the heater using a 10% citric acid solution and rinse.

2.2. Belüftung der Saunakabine

Die Saunaluft sollte sechsmal pro Stunde ausgetauscht werden. Abb. 5 zeigt verschiedene Optionen der Saunabelüftung.

- A. Luftzufuhr. Bei mechanischer Entlüftung Luftzufuhr über dem Ofen anbringen. Bei Schwerkraftentlüftung Luftzufuhr unter oder neben dem Ofen anbringen. Der Durchmesser des Luftzufuhrrohres muss 50–100 mm betragen. **BC-E: Luftzufuhr nicht so anbringen, dass sie den Temperaturfühler abkühlt (zur Anbringung des Temperaturfühlers siehe Installationsanweisungen des Steuergeräts)!**
- B. Entlüftung. Entlüftung in Bodennähe anbringen, so weit weg vom Ofen wie möglich. Der Durchmesser des Entlüftungsrohres sollte doppelt so groß sein wie bei der Luftzufuhr.
- C. Optionale Lüftung zum Trocknen (während Heizung und Bad geschlossen). Die Sauna kann auch durch die offene Tür getrocknet werden.
- D. Wenn die Entlüftung im Waschraum liegt, muss die Lücke unter der Saunatur mindestens 100 mm betragen. Mechanische Entlüftung ist Pflicht.

2.3. Leistungsabgabe des Ofens

Wenn Wand und Decke vertäfelt und ausreichend isoliert sind, richtet sich die Leistungsabgabe des Ofens nach dem Volumen der Sauna. Nicht isolierte Wände (Stein, Glasbausteine, Glas, Beton, Kacheln) erhöhen die benötigte Ofenleistung. Jeder Quadratmeter nicht isolierter Wand entspricht 1,2 m³ mehr Saunavolumen. Eine 10 m³ große Saunakabine mit Glastür z.B. entspricht in der Leistungsabgabe einer 12 m³ großen Sauna. Bei Balkenwänden Saunavolumen mit 1,5 multiplizieren. Korrekte Leistungsabgabe des Ofens aus Tabelle 2 wählen.

2.4. Hygiene der Saunakabine

Liegetücher benutzen, um die Bänke vor Schweiß zu schützen.

Bänke, Wände und Boden der Sauna mindestens alle sechs Monate waschen. Bürste und Saunareinigungsmittel verwenden.

Staub und Schmutz vom Ofen mit feuchtem Tuch abwischen. Kalkablagerungen am Ofen mit 10 % Zitronensäure entfernen und spülen.

3. INSTRUCTIONS FOR INSTALLATION

3.1. Before Installation

Before installing the heater, study the instructions for installation. Check the following points:

- Is the output and type of the heater suitable for the sauna room? **The cubic volumes given in table 2 should be followed.**
- Is the supply voltage suitable for the heater?
- The location of the heater fulfils the minimum requirements concerning safety distances given in fig. 6 and table 2.

It is absolutely necessary to install the heater according to these values. Neglecting them causes a risk of fire. Only one electrical heater may be installed in the sauna room.

3. INSTALLATIONSANLEITUNG

3.1. Vor der Montage

Bevor Sie den Saunaofen installieren, lesen Sie die Montageanleitung und überprüfen Sie folgende Dinge:

- Ist der zu montierende Saunaofen in Leistung und Typ passend für die Saunakabine? **Die Rauminhaltswerte in Tabelle 2 dürfen weder über noch unterschritten werden.**
- Ist die Netzspannung für den Saunaofen geeignet?
- Der Montageort des Ofens erfüllt die in Abbildung 6 und Tabelle 2 angegebenen Sicherheitsmindestabstände.

Diese Abstände müssen unbedingt eingehalten werden, da ein Abweichen Brandgefahr verursacht. In einer Sauna darf nur ein Saunaofen installiert werden.

Heater Ofen	Output Leistung	Sauna room Saunakabine			Electrical connections Elektroanschlüsse				
		Cubic vol. Rauminhalt		Height Höhe	400 V 3N~		230 V 1N~		To sensor (BC-E) An Fühler (BC-E)
Model and dimensions/ Modell und Maße		min. m ³	max. m ³	min. mm	Connecting cable Anschlusskabel	Fuse Sicherung	Connecting cable Anschlusskabel	Fuse Sicherung	
Width/Breite • BC 480 mm • BC-E 450 mm Depth/Tiefe 310 mm Height/Höhe 540 mm Weight/Gewicht 11 kg Stones/Steine max. 20 kg	kW				mm ²	A	mm ²	A	mm ²
BC45/BC45E	4,5	3	6	1900	5 x 1,5	3 x 10	3 x 2,5	1 x 20	4 x 0,25
BC60/BC60E	6,0	5	8	1900	5 x 1,5	3 x 10	3 x 2,5	1 x 35	4 x 0,25
BC80/BC80E	8,0	7	12	1900	5 x 2,5	3 x 16	3 x 6	1 x 35	4 x 0,25
BC90E	9,0	8	14	1900	5 x 2,5	3 x 16	3 x 10	1 x 50	4 x 0,25

Table 2. Installation details

Tabelle 2. Montageinformationen

The heater can be mounted in a recess with a minimum height of 1900 millimetres.

Der Saunaofen kann in einer Wandnische angebracht werden, deren Höhe min. 1900 mm beträgt.

	A min. from side to wall, upper platform or rail von der Seitenfläche zur Wand, zur oberen Bank oder zum oberen Geländer	B min.	C min. from front surface to upper platform or rail von der Vorderfläche zur oberen Bank oder zum oberen Geländer
BC45/BC45E	35	20	35
BC60/BC60E	50	30	50
BC80/BC80E	100	30	80
BC90E	120	40	100

Figure 6. Safety distances (all dimensions in millimeters)

Abbildung 6. Sicherheitsmindestabstände (alle Abmessungen in Millimetern)

3.2. Fastening the Heater on a Wall

See figure 7.

1. Remove both cardboard covers before installation.
2. Fasten the wall-mounting rack on the wall by using the screws which come with the rack.
NOTE! There must be a support, e.g. a board, behind the panel, so that the fastening screws can be screwed into a thicker wooden material than the panel. If there are no boards behind the panel, the boards can also be fastened on the panel.
3. The right- or left-handedness of the heater can be changed by installing it to the rack correspondingly. Make sure the clip fastens in the hole properly.
4. Lift the heater to the rack on the wall so that the fastening hooks of the lower part of the rack go behind the edge of the heater body. Lock the edge of the heater onto the rack by a screw.

3.2. Befestigung des Saunaofens an der Wand

Siehe Abbildung 7.

1. Beide Schutzpappen vor der Montage entfernen!
2. Befestigen Sie das Montagegestell mit den dazu gelieferten Schrauben an der Wand.
ACHTUNG! An den Stellen, an denen die Befestigungsschrauben angebracht werden, muss sich hinter den Paneelen als Stütze z.B. ein Brett befinden, in dem die Schrauben fest sitzen. Falls sich hinter den Paneelen keine Bretter befinden, können diese auch vor den Paneelen angebracht werden.
3. Der Saunaofen kann zur Bedienung durch Rechts- oder Linkshänder unterschiedlich an der Wand montiert werden. Versichere, dass die Befestigungs-Ösen richtig dafür vorgesehene Aufhängung sitzen.
4. Heben Sie den Saunaofen so auf das Gestell an der Wand, daß die Befestigungshaken unten am Gestell hinter den Rand des Saunaofenrumpfes kommen. Schrauben Sie den oberen Rand des Saunaofens am Montagegestell fest.

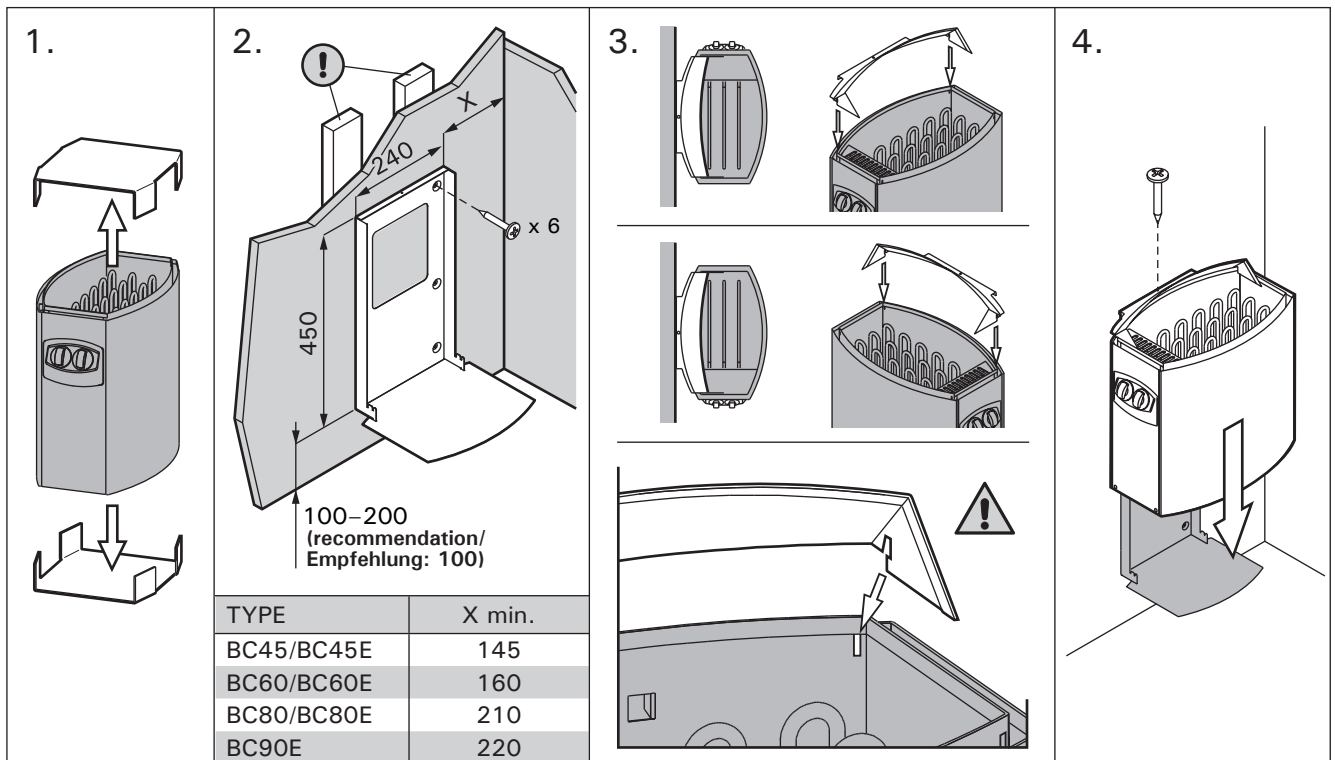

Figure 7. Fastening the heater on a wall (all dimensions in millimeters)
Abbildung 7. Befestigung des Saunaofens an der Wand (alle Abmessungen in Millimetern)

3.3. Electrical Connections

The heater may only be connected to the electrical network in accordance with the current regulations by an authorised, professional electrician.

- The heater is semi-stationarily connected to the junction box (figure 8: A) on the sauna wall. The junction box must be splash-proof, and its maximum height from the floor must not exceed 500 mm.
- The connecting cable (figure 8: B) must be of rubber cable type H07RN-F or its equivalent. **NOTE! Due to thermal embrittlement, the use of PVC-insulated wire as the connecting cable of the heater is forbidden.**
- If the connecting and installation cables are higher than 1000 mm from the floor in the sauna or inside the sauna room walls, they must be able to endure a minimum temperature of 170 °C when loaded (for example, SSJ). Electrical equipment installed higher than 1000 mm from the sauna floor must be approved for use in a temperature of 125 °C (marking T125).
- In addition to supply connectors, the BC heaters are equipped with a connector (P), which makes the control of the electric heating possible (figure 10). Voltage control is transmitted from the heater when it is switched on. The control cable for electrical heating is brought directly into the junction box of the heater, and from there to the terminal block of the heater along a rubber cable with the same cross-section area as that of the connecting cable.
- **When closing the cover of the connection box make sure that the upper edge of the cover is placed correctly.** If the upper edge is misplaced water can enter the connection box. Figure 8.

3.3. Elektroanschlüsse

Der Anschluss des Saunaofens an das Stromnetz darf nur von einem zugelassenen Elektromonteur unter Beachtung der gültigen Vorschriften ausgeführt werden.

- Der Saunaofen wird halbfest an die Klemmdose (Abb. 8: A) an der Saunawand befestigt. Die Klemmdose muß spritzwasserfest sein und darf höchstens 500 mm über dem Fußboden angebracht werden.
- Als Anschlusskabel (Abb. 8: B) wird ein Gummikabel vom Typ H07RN-F oder ein entsprechendes Kabel verwendet. **ACHTUNG! PVC-isolierte Kabel dürfen wegen ihrer schlechten Hitzebeständigkeit nicht als Anschlusskabel des Saunaofens verwendet werden.**
- Falls der Anschluss oder die Montagekabel höher als in 1000 mm Höhe über dem Boden in die Sauna oder die Saunawände münden, müssen sie belastet mindestens eine Temperatur von 170 °C aushalten (z.B. SSJ). Elektrogeräte, die höher als 1000 mm vom Saunaboden angebracht werden, müssen für den Gebrauch bei 125 °C Umgebungstemperatur zugelassen sein (Vermerk T125).
- Die BC-Saunaöfen sind zusätzlich zum Netzanschluss mit einer Klemme (P) ausgestattet, welche die Möglichkeit zur Steuerung der Elektroheizung bietet (Abb. 10). Der Ofen übernimmt mit dem Einschalten die Spannungsregelung. Das Steuerungskabel für die Elektroheizung wird direkt zur Klemmdose des Saunaofens gelegt und von dort aus durch ein Gummikabel der gleichen Stärke weiter zur Reihenklemme des Saunaofens geleitet.
- **Achten Sie beim Schließen des Deckels des Anschlusskastens darauf, dass sich der Deckel vollständig verschließt.** Wenn der Deckel nicht richtig sitzt, kann Wasser in den Anschlusskasten laufen. Abbildung 8.

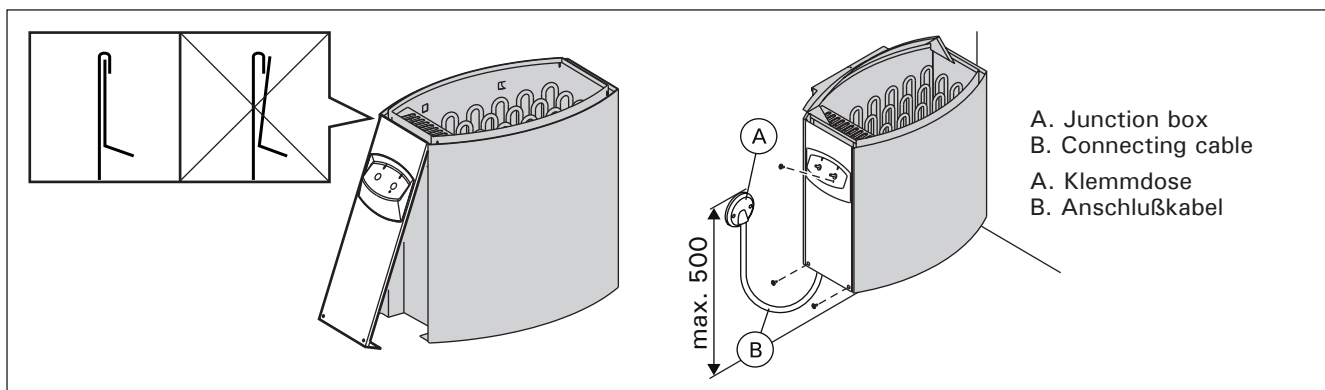

Figure 8. Closing the cover of the connection box (all dimensions in millimeters)
Abbildung 8. Das Verschließen des Anschlusskastens (alle Abmessungen in Millimetern)

3.3.1. Electric Heater Insulation Resistance

When performing the final inspection of the electrical installations, a "leakage" may be detected when measuring the heater's insulation resistance. The reason for this is that the insulating material of the heating elements has absorbed moisture from the air (storage, transport). After operating the heater for a few times, the moisture will be removed from the heating elements.

Do not connect the power feed for the heater through the RCD (residual current device)!

3.3.1. Isolationswiderstand des Elektrosaunaofens

Bei der Endkontrolle der Elektroinstallationen kann bei der Messung des Isolationswiderstandes ein "Leck" auftreten, was darauf zurückzuführen ist, daß Feuchtigkeit aus der Luft in das Isolationsmaterial der Heizwiderstände eingetreten ist (bei Lagerung und Transport). Die Feuchtigkeit entweicht aus den Widerständen nach zwei Erwärmungen.

Schalten Sie den Netzstrom des Elektrosaunaofens nicht über den Fehlerstromschutzschalter ein!

3.4. Installation of the Control Unit and Sensors (BC-E)

The control unit includes detailed instructions for fastening the unit on the wall. Install the temperature sensor on the wall of the sauna room above the heater. It should be installed on the lateral centre line of the heater, 100 mm downwards from the ceiling. Figure 6.

Do not place the supply air vent so that the air flow cools the temperature sensor. Figure 5.

3.5. Resetting the Overheat Protector

If the temperature of the sauna room becomes dangerously high, the overheat protector will permanently cut off the supply of the heater. The overheat protector can be reset after the heater has cooled down.

BC

The reset button is located inside the heater's connection box (figure 9). **Only persons authorised to carry out electrical installations can reset the overheat protector.**

Prior to pressing the button, the cause of the fault must be found.

- Are the stones crumbled and pressed together?
- Has the heater been on for a long time while unused?
- Is the sensor of the thermostat out of place or broken?
- Has the heater been banged or shaken?

BC-E

See the installation instructions for control unit.

3.4. Anschluß des Steuergerätes und der Fühler (BC-E)

In Verbindung mit dem Steuergerät werden genauere Anweisungen zu dessen Befestigung an der Wand gegeben. Der Temperaturfühler wird an der Saunawand oberhalb des Saunaofens, 100 mm unterhalb der Decke auf der Achse in Breitenrichtung des Saunaofens angebracht. Abbildung 6.

Luftzufuhr nicht so anbringen, dass sie den Temperaturfühler abkühlt. Abbildung 5.

3.5. Zurückstellen des Überhitzungsschutzes

Wenn die Temperatur in der Saunakabine gefährlich stark ansteigt, unterbricht der Überhitzungsschutz die Stromzufuhr zum Ofen permanent. Der Überhitzungsschutz kann nach Abkühlen des Ofens zurückgesetzt werden.

BC

Der Rücksetzknopf befindet sich im Anschlussgehäuse des Ofens (Abb. 9). **Nur eine zu Elektroinstallationen befugte Person darf diese Arbeit ausführen.**

Vor Betätigung des Knopfes muß die Ursache der Fehlfunktion festgestellt werden:

- Sind die Steine im Saunaofen verkeilt oder spröde?
- War der Saunaofen lange angeschaltet und wurde nicht benutzt?
- Ist der Thermostatfühler an einem falschen Platz oder defekt?
- War der Saunaofen starken Stößen ausgesetzt?

BC-E

Siehen Sie Gebrauchs- und Montageanleitung des Steuergeräts.

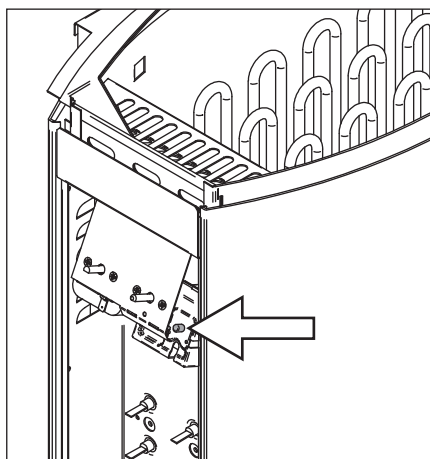

Figure 9. Reset button for overheat protector
Abbildung 9. Rücksetzknopf des Überhitzungsschutzes

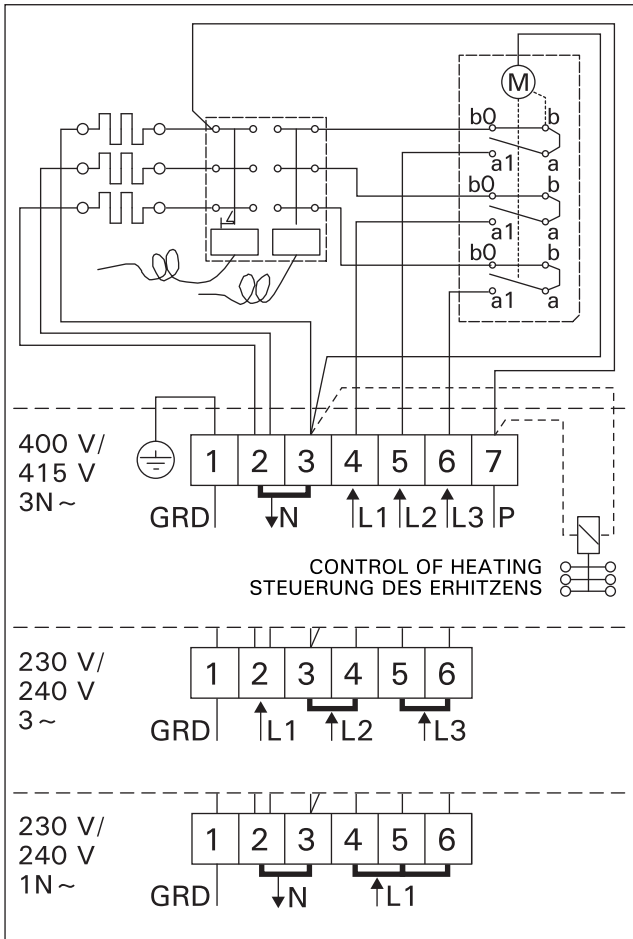

Figure 10. Electrical connections of BC heater
Abbildung 10. Elektroanschlüsse des Saunaofens BC

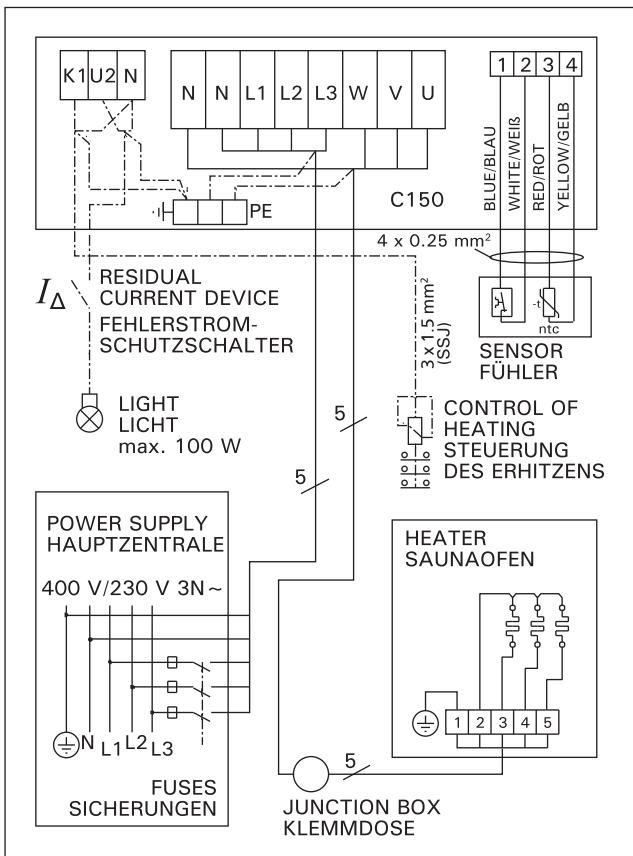

Figure 12a. 3-phase electrical connections of control unit C150 and BC-E heater
Abbildung 12a. 3-phasiger Elektroanschlüsse das Steuergerät C150 und des Saunaofens BC-E

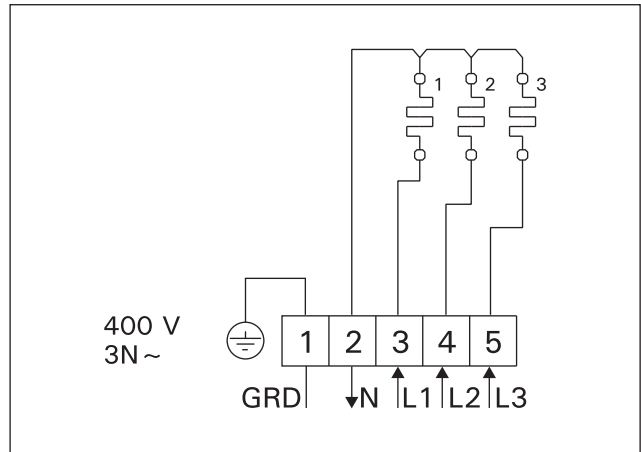

Figure 11. Electrical connections of BC-E heater
Abbildung 11. Elektroanschlüsse des Saunaofens BC-E

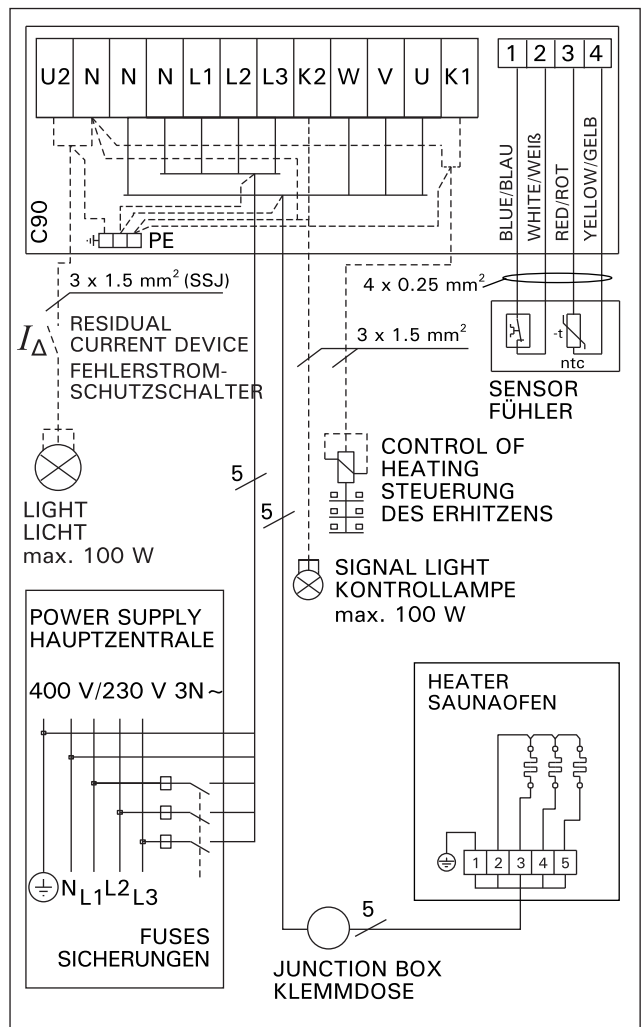
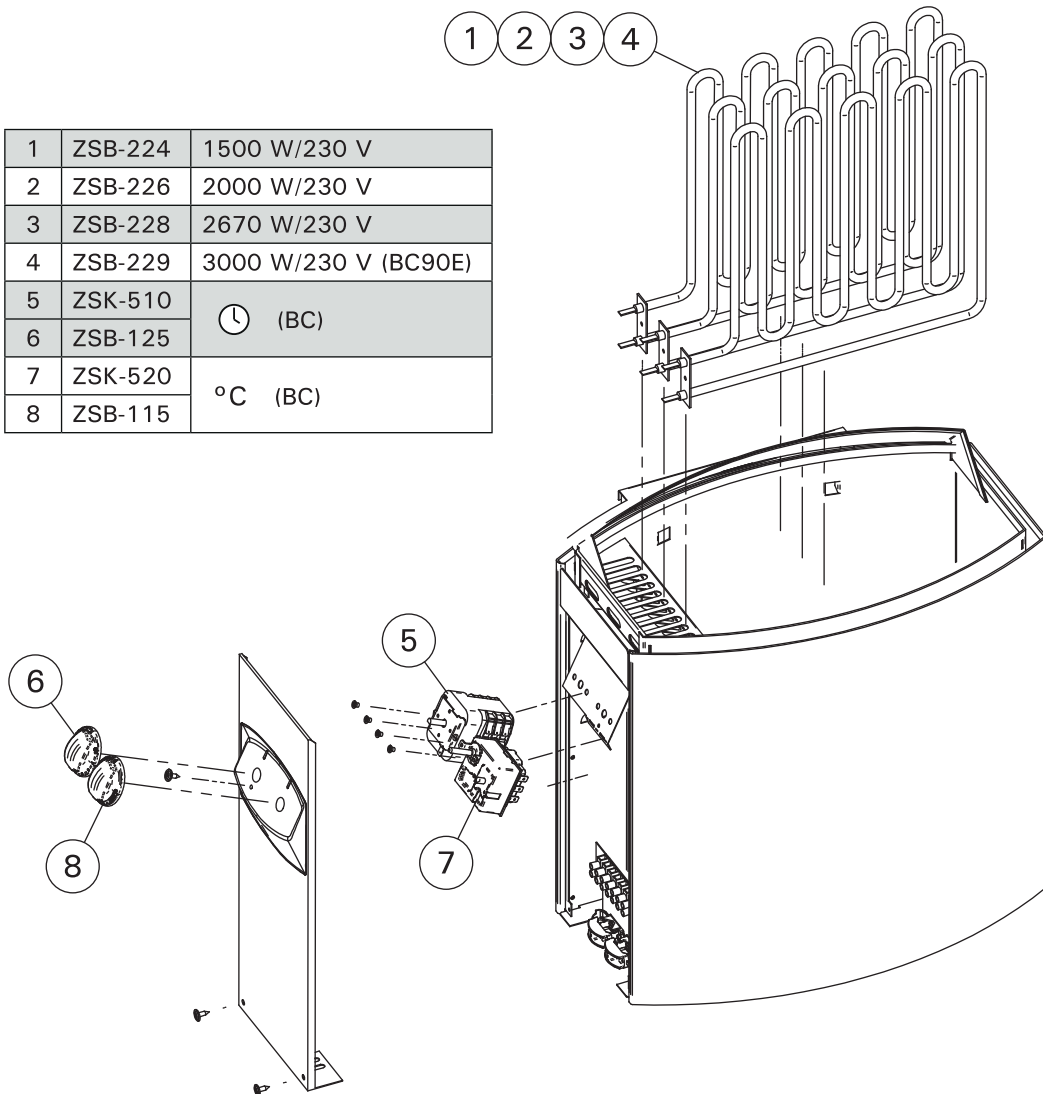

Figure 12b. 3-phase electrical connections of control unit C90 and BC-E heater
Abbildung 12b. 3-phasiger Elektroanschlüsse das Steuergerät C90 und des Saunaofens BC-E

4. SPARE PARTS

4. ERSATZTEILE

1	ZSB-224	1500 W/230 V
2	ZSB-226	2000 W/230 V
3	ZSB-228	2670 W/230 V
4	ZSB-229	3000 W/230 V (BC90E)
5	ZSK-510	⌚ (BC)
6	ZSB-125	
7	ZSK-520	°C (BC)
8	ZSB-115	



HARVIA

Harvia Oy
 PL12
 40951 Muurame
 Finland
www.harvia.fi

Instruction Manual

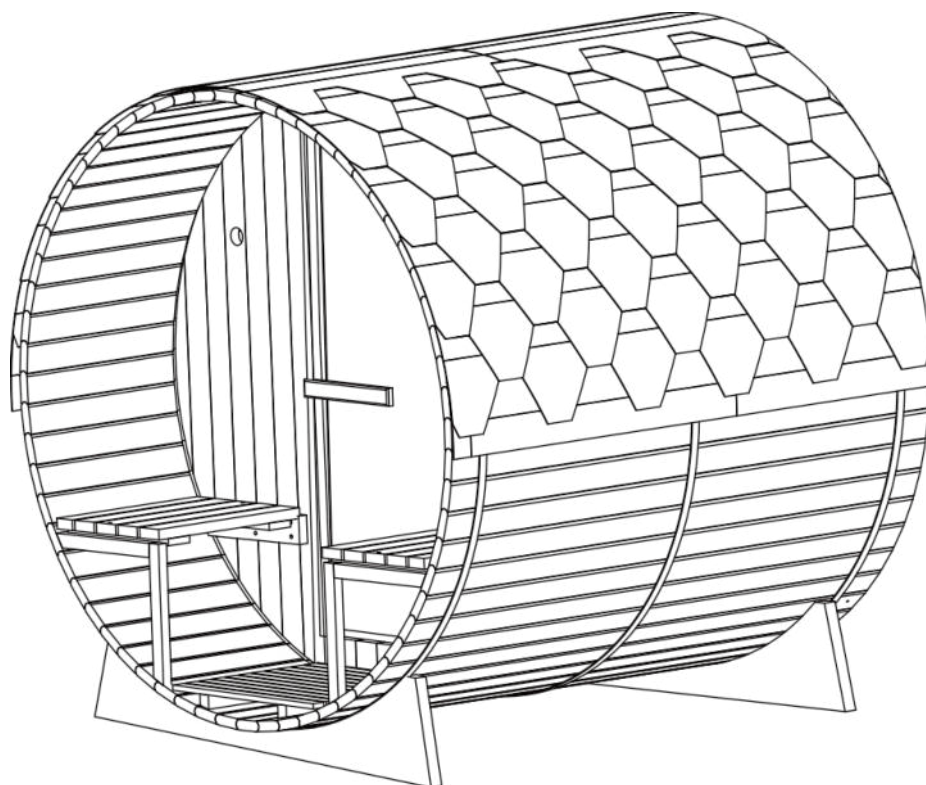

— Infrared makes life more healthy—

Due to our continued product improvement, product illustrated on this instruction manual may vary slightly from the actual product.

Recommendations

Read this manual carefully before using your sauna for the first time.

We recommend you keep it in a safe place for future reference.

- Wood is a living element, to maintain its original appearance, it is important to treat the outside of the wood against moisture.
- Install the sauna on a perfectly flat and hard surface.
- Do not use liquid cleaning products. Disconnect the sauna before cleaning and use a wet rag .
- Protect the sauna's electrical cable to avoid it being crushed or pinched.
- Prior to replacing certain components, ensure that they are specified by the manufacturer or that they have the same features as the original parts. Incorrect replacement can cause a fire, a short circuit or damage to the sauna. We strongly recommend using a qualified technician.
- To avoid the risk of burns or electric shocks, do not use any metal tools.
- Do not put animals in the sauna.
- Do not leave the sauna switched on without supervision.
- Do not leave the sauna switched on for more than 3 hours at a time to avoid premature deterioration of the equipment. After 3 hours continuous usage, switch off the sauna for at least one hour.
- We recommend that you do not install a locking system on the sauna door.
- Check compliance of your electrical installation prior to connecting your sauna to the power supply.

Safety

IMPORTANT :

Please read the safety instructions carefully before installing and using your sauna cabin. They are essential for your safety, so please adhere strictly to them.

Beware of hyperthermia, heat stroke or heat exhaustion which can be caused or aggravated by noncompliance with the safety instructions. Symptoms are fever, a rapid pulse, dizziness, fainting, lethargy and numbness in all or part of the body. The effects are: reduced awareness of the heat, ignorance of imminent risks, loss of consciousness.

The sauna must not be used by:

- Children under 6 years of age.
- People with severe reactions to sunlight.
- Elderly or disabled people.
- People with previous medical conditions such as heart disease, high or low blood pressure, blood circulation problems or diabetes without prior medical advice.
- Pregnant women. Excessive temperature can endanger the foetus.
- Persons suffering from dehydration, open sores, eye disorders, burns or sunstroke.

Children between 6 and 16 years of age may use the sauna provided that they are continuously supervised by a responsible adult and that the temperature does not exceed 60°C (140°F).

In the event of problems involving health, medication or injury to muscles or ligaments, do not use the sauna without previously consulting a doctor and obtaining approval.

If surgical implants are worn, do not use the sauna without previously consulting a doctor and obtaining his approval.

Do not use the sauna after strenuous activity.

Wait 30 minutes for your body to cool down.

Do not spend more than 40 minutes in the sauna at any one time.

Do not consume alcohol or drugs before or during the session.

Do not sleep in the sauna when it is in operation.

To avoid the risk of overheating, connect your sauna to a sufficiently powerful electrical outlet and do not connect other electrical equipment to the same wall socket.

To avoid any risk of electrocution or damage to the sauna, do not use it:

- During thunderstorms.
- If the electrical cable is damaged, it must be replaced by a qualified person.
- If the electrical cable overheats, it must be checked by a qualified person.
- If you have to change a bulb, wait until the sauna is switched off and cooled down.

Dry your hands before connecting or disconnecting the electricity.

Never work with wet hands or feet.

Do not switch the electricity or the heating system rapidly on or off as this could damage the electrical system.

Do not try to repair the sauna by yourself without the agreement of the sauna's distributor or manufacturer.

Unauthorized attempts to repair it will invalidate the manufacturer's warranty.

Do not use any type of detergent inside the sauna.







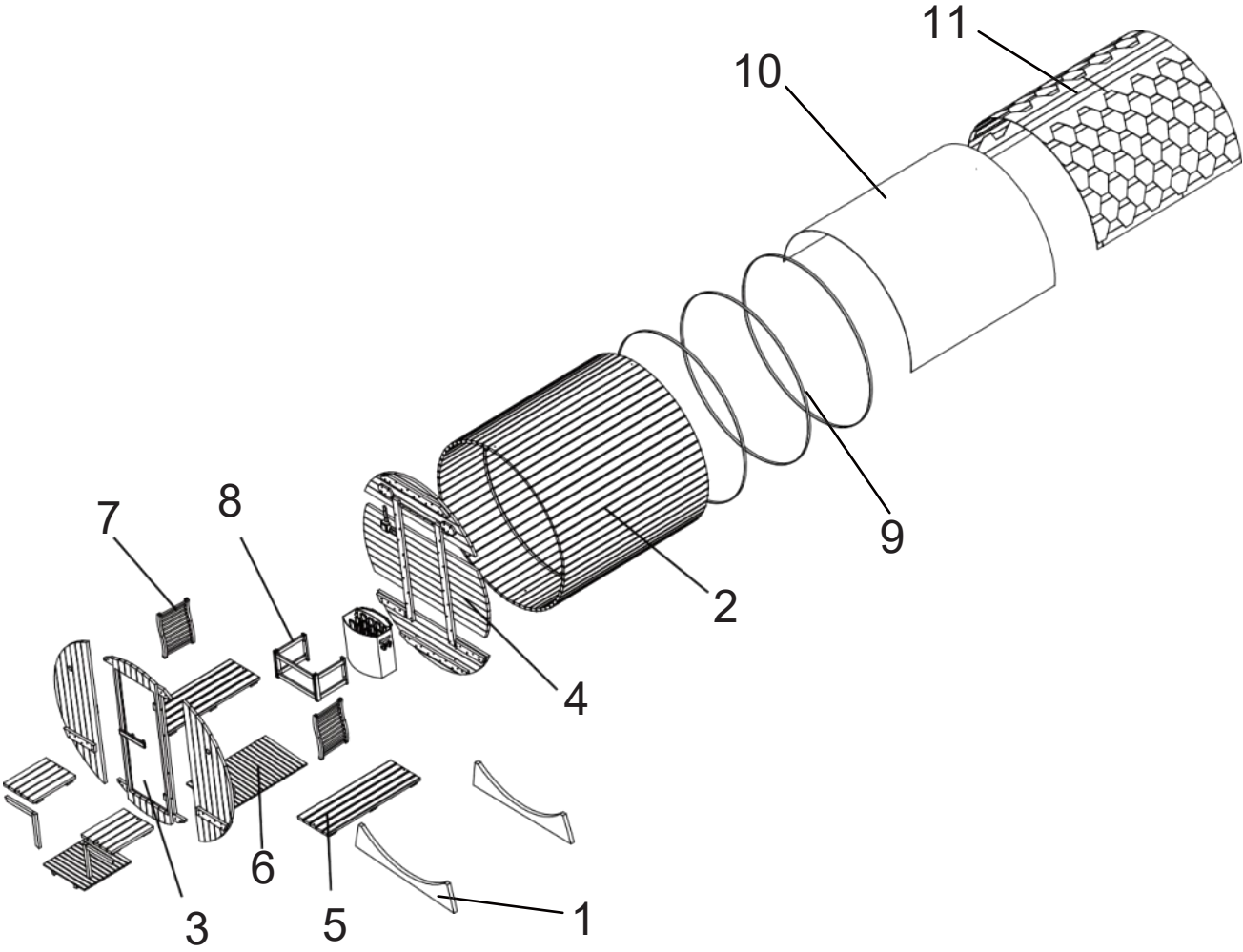



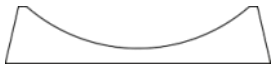

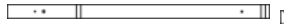
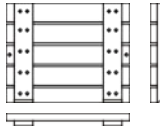

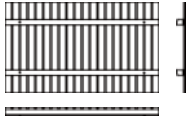
Do not pile up or store objects inside or on top of the sauna.

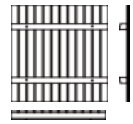
Do not place flammable materials or chemical agents near the sauna.

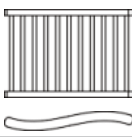
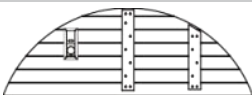
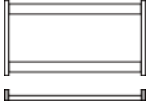
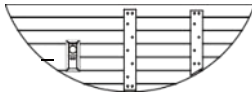
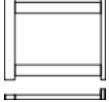
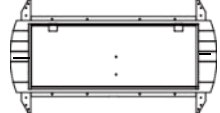

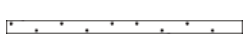
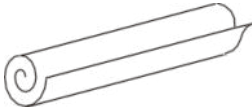

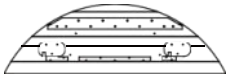
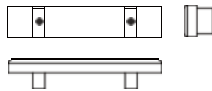
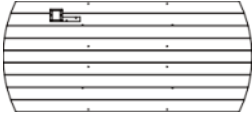
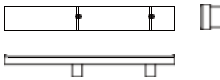

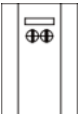
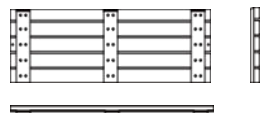
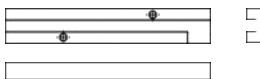
Description sauna



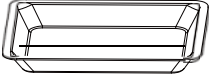

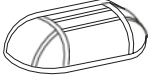

Description sauna

1		(1400x300x33mm) 2x	5.2		(426x398x30mm) 2x
2.1		(1800x93x30mm) 2x	5.3		(532x425x50mm) 2x
2.2		(1800x93x30mm) 1x	6.1		(990x585x40mm) 1x
2.3		(1800x93x30mm) 60x	6.2		(535x585x40mm) 1x
2.4		(1800x93x30mm) 1x	7		(520x330x65mm) 2x
3.1		(1758x575x30mm) 1x	8.1		(560x300x40mm) 1x
3.2		(1650x575x30mm) 1x	8.2		(378x300x40mm) 2x
3.3		(1758x952x30mm) 1x	9		3x Barrel hoop
4.1		(1404x80x20mm) 1x	10		(3000x1800mm) 1x
4.2		(1404x80x20mm) 1x	11		(1000x320mm) 60x
4.3		(1574x488x30mm) 1x	12		(250x50x45mm) 1x
4.4		(1758x783x30mm) 1x	13		(350x50x45mm) 1x
4.5		(1574x488x30mm) 1x	14		1x Sauna stove
5.1		(1152x425x50mm) 2x	15		(177x80x30mm) 1x

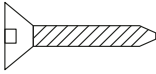
Description sauna

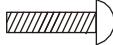
16		1x Water pan	20		1x Hygrometer
17		2x Explosion proof lampshade	21		1x Hourglass
18		2x Cup plate	22		1x Wooden spoon
19		1x Wooden barrel			

							
Ø5x50	Ø4x50	Ø4x30	Ø3x35	Ø4x12	Ø6x70		
44x	20x	8x	66x	240x	2x	2x	

Read the assembly instructions carefully before starting.

Choice of location

Designed solely for exterior installation.

Select a space:

- In a dry area, on a flat stable surface that can support the weight of your sauna.
- The height must be sufficient for you to reach the ceiling and carry out electrical connections and maintenance.
- Away from any source of water, flames or flammable materials.

Practical advice

- Note that sauna assembly requires 3 adults.
- Clearly identify each panel before you begin
- During assembly, position your sauna's mains cable so that it is easily accessible.
- Note that there are variations between the models.

IMPORTANT :

Please check the countersink and hole diameter of the drill holes to avoid damaging the wood.

Tools needed



Screwdriver



Tape measure



Pencil



Cutter



2 Spanner

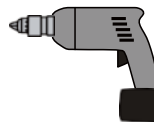

Electric
screwdriver



Wood spiral drill



Allen Wrench



Step ladder

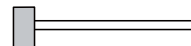

Mallet

Assemble instructions

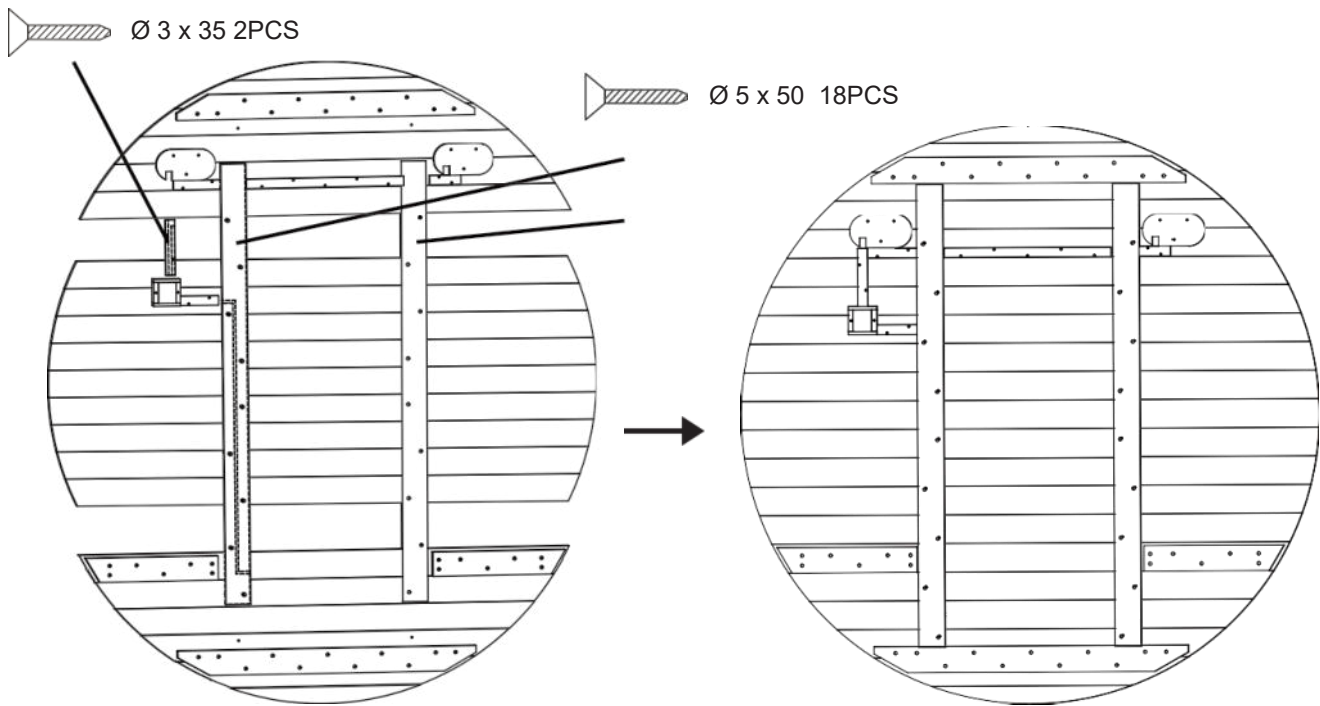
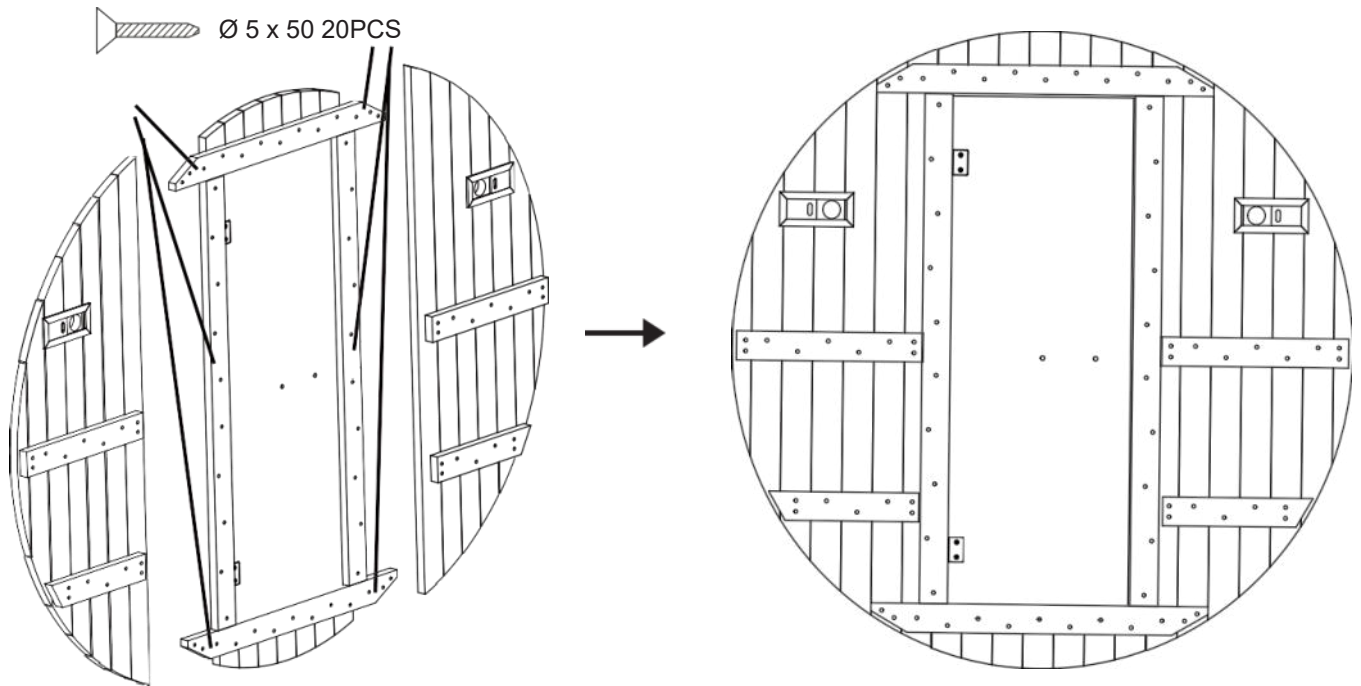

The front and rear panels need to be assembled as a whole first.
The front panel is divided into three parts on the left and right, and the rear panel is divided into three parts on the top and bottom.

Assemble instructions

Assemble steps

 Ø 5 x 50 2PCS

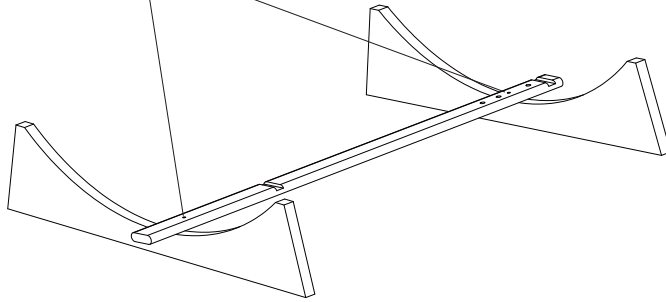

Undersupport

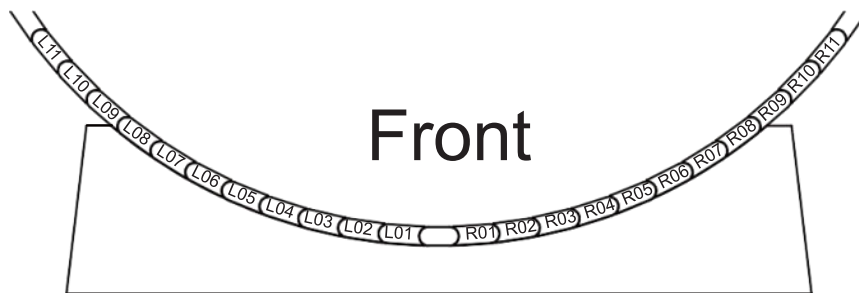
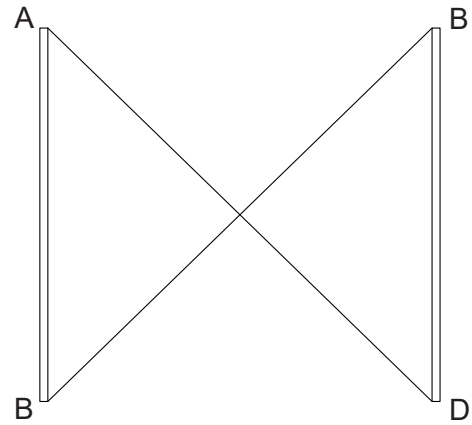

Each slat is numbered and labeled.

The left side is L01 L02 L03..... L38 from bottom to top;

The right side is R01 R02 R03..... R38 from bottom to top.

Assemble instructions

Assemble steps

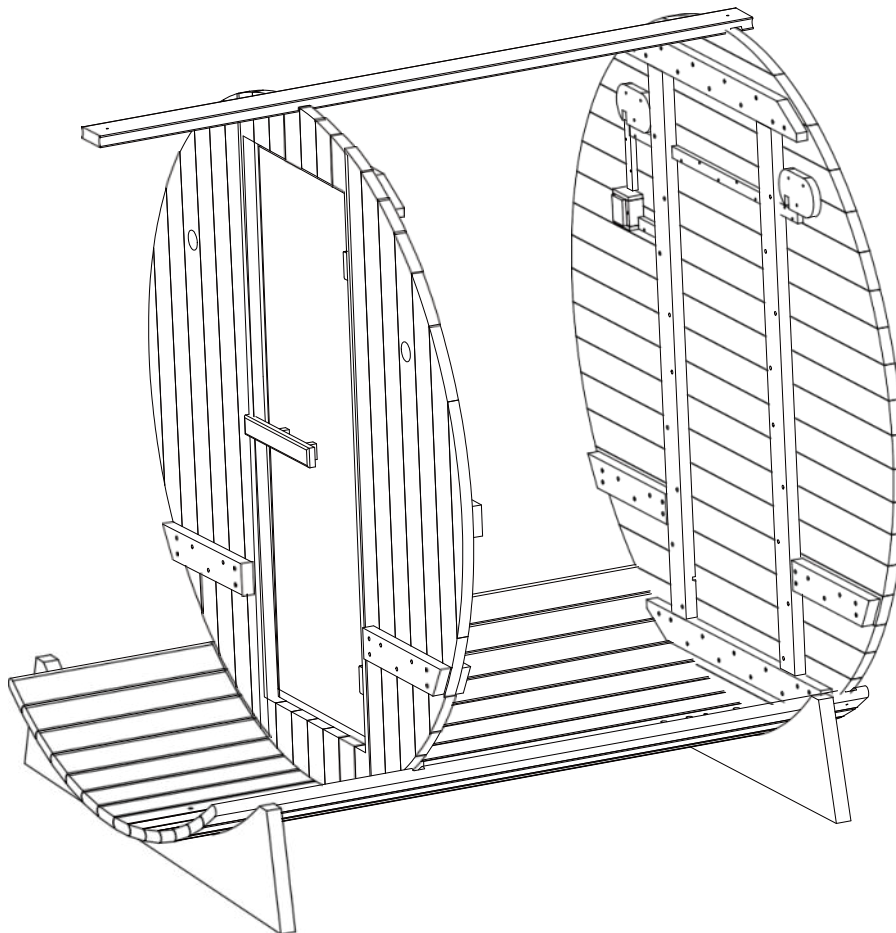
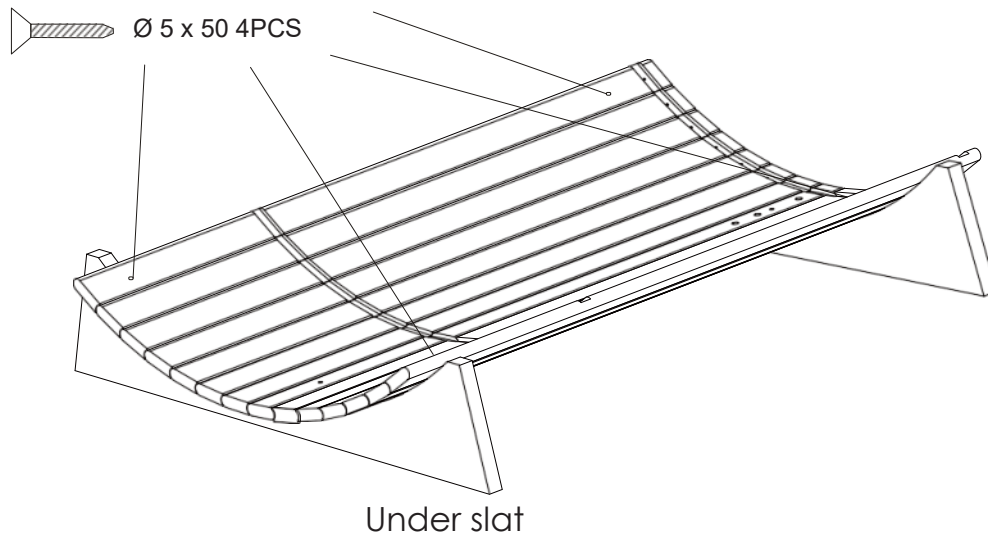

The top Flat shall be temporarily installed as a fixed protective measure during installation.

Assemble instructions

Assemble steps

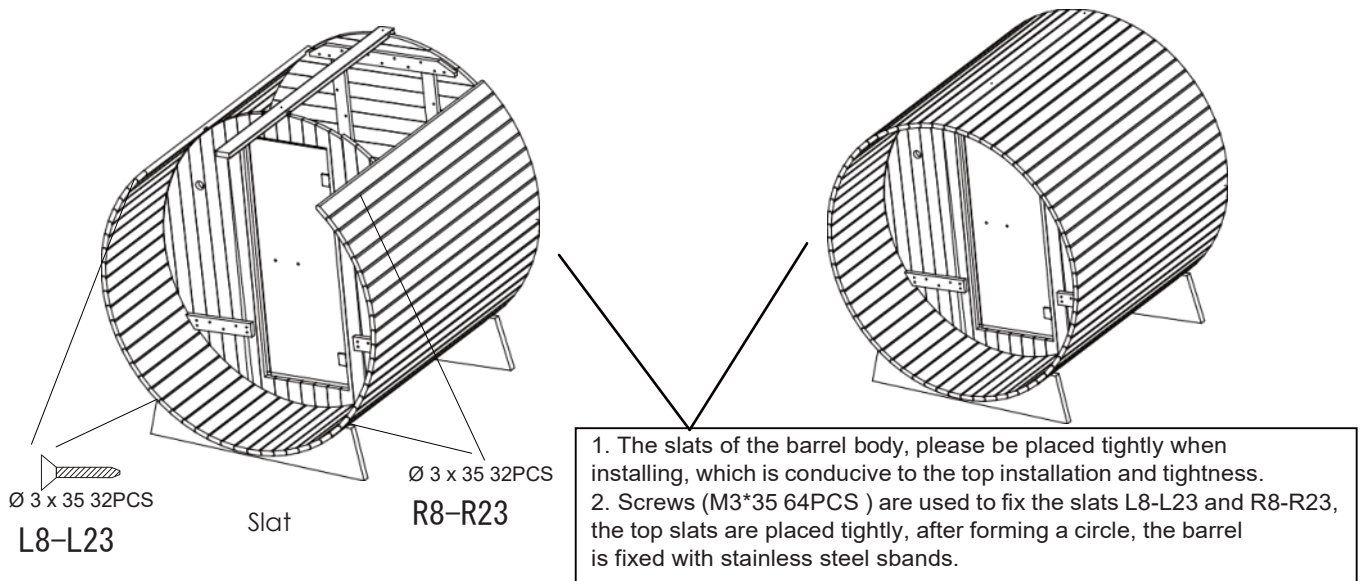

According to actual installation needs, one or two thin plates in the middle can be removed after loosening the screws.

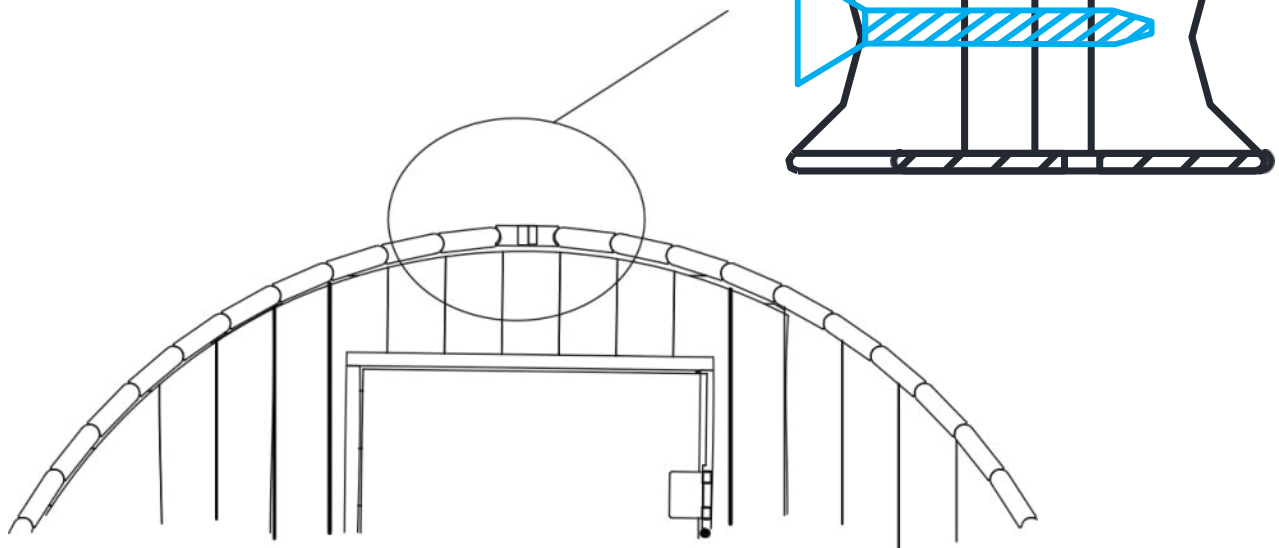

Assemble instructions

Assemble steps

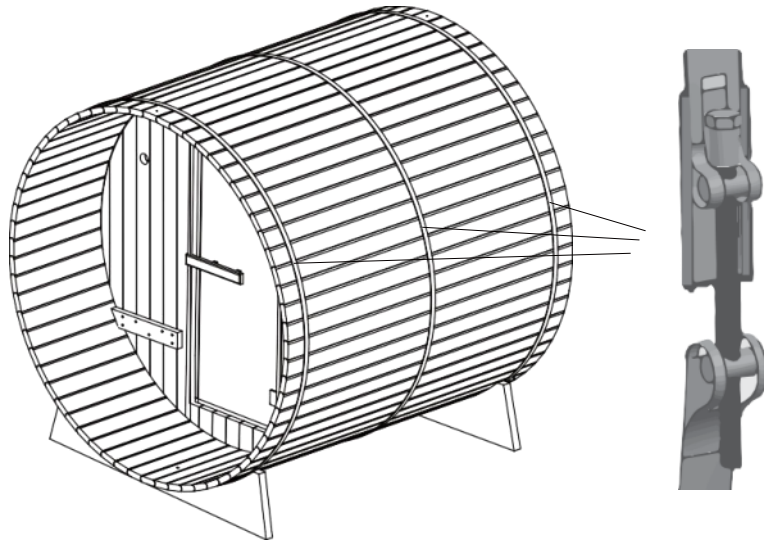

Stainless steel bands

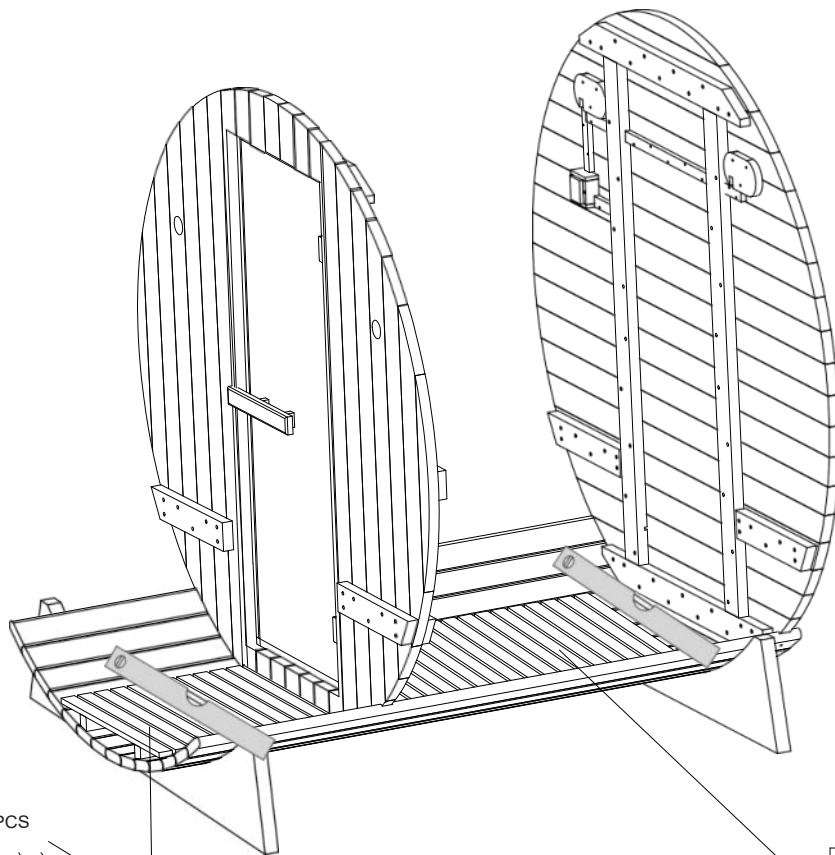

$\text{Ø } 4 \times 50 \text{ 4PCS}$

$\text{Ø } 4 \times 50 \text{ 4PCS}$

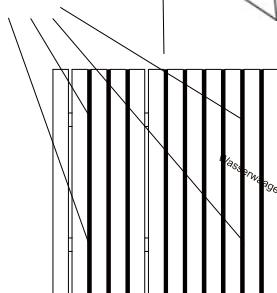

Wasserwaage

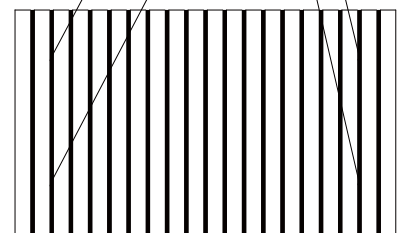

Footrest

Assemble instructions

Assemble steps

The support of the inner and outer seat plates has been pre installed on the front and rear plates.
 The outer base plate needs another support frame, and the support frame locks the screws onto the Flat noodles.
 The inner base plate does not need another support frame.
 The seat plate lock screws need to be fixed on the support side of the front and rear plates.

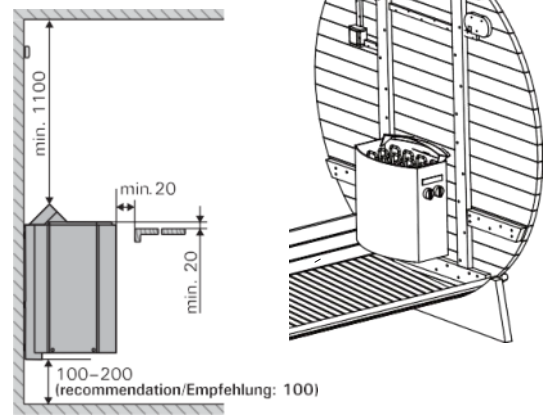
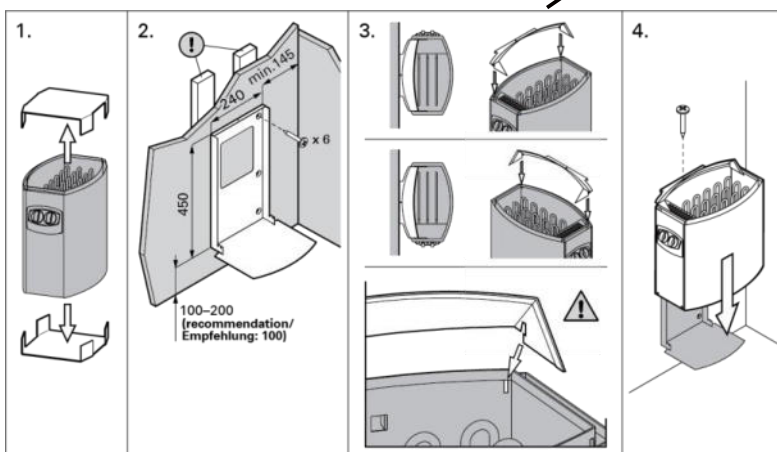
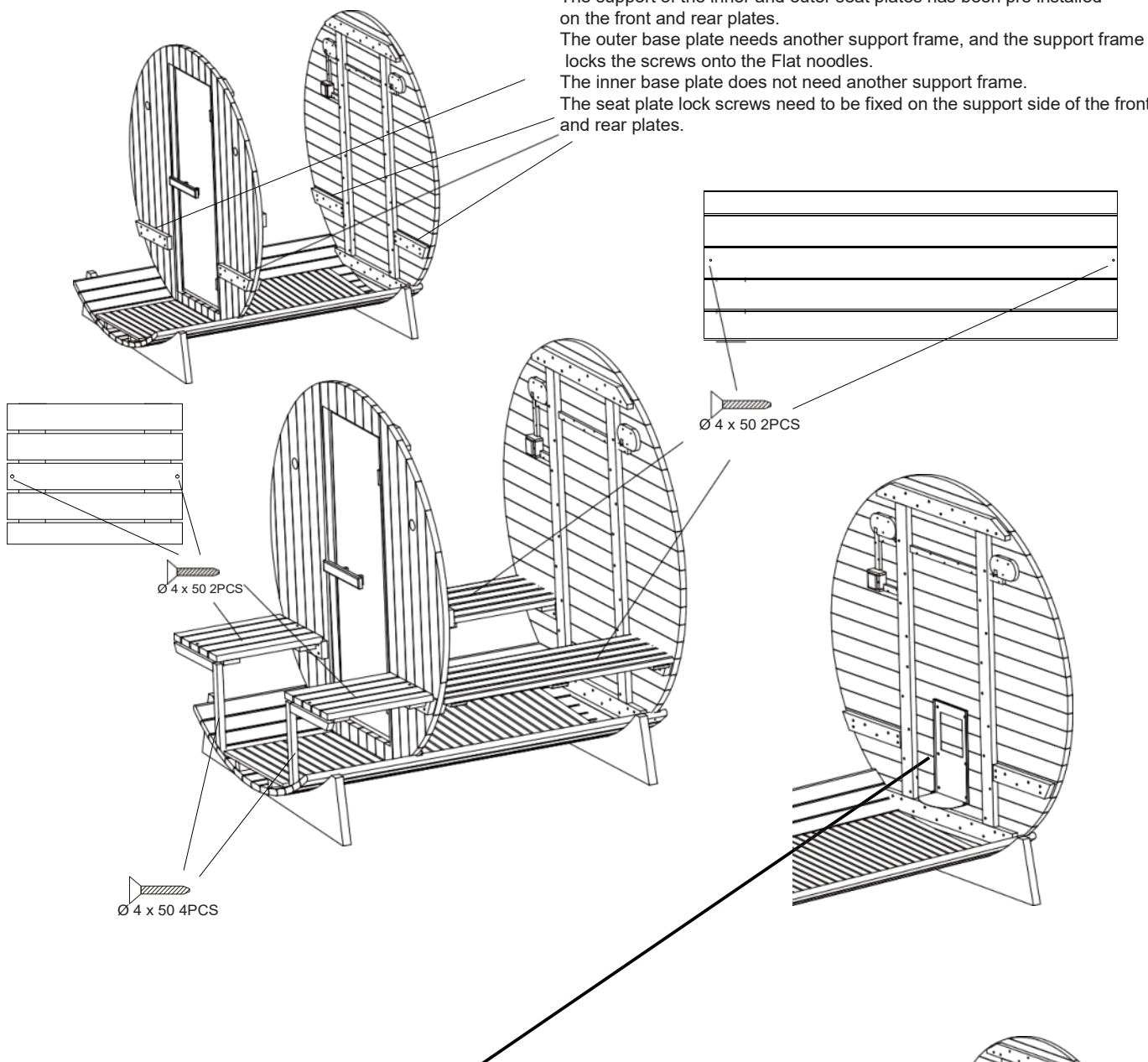

The installation of a sauna requires the installation of the wall bracket of the furnace frame first, and then the furnace is hung up. Please refer to the diagram for specific information. For more detailed information, please read the manual provided with the sauna stove.

The sauna stove is a universal cable connected to an external customer power supply. The wires of the lamp should be connected to the wiring base of the sauna stove and powered through the sauna stove.

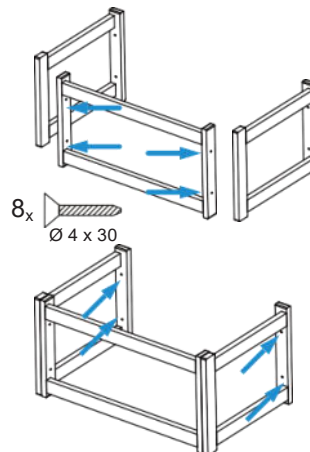
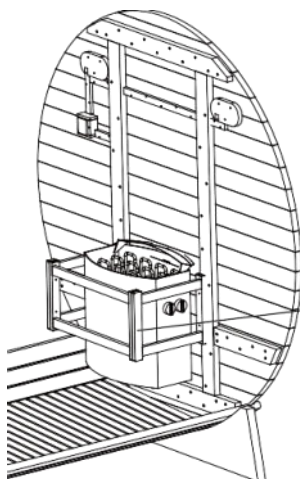
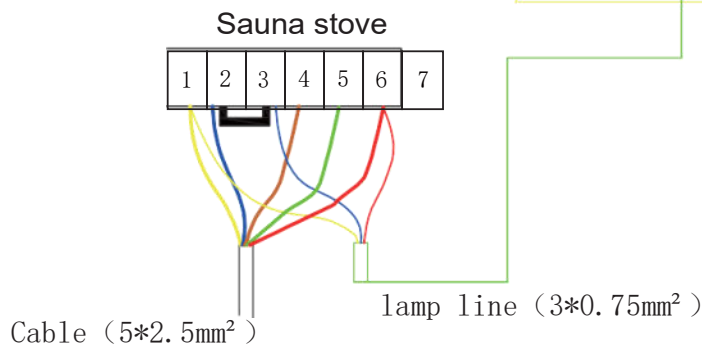
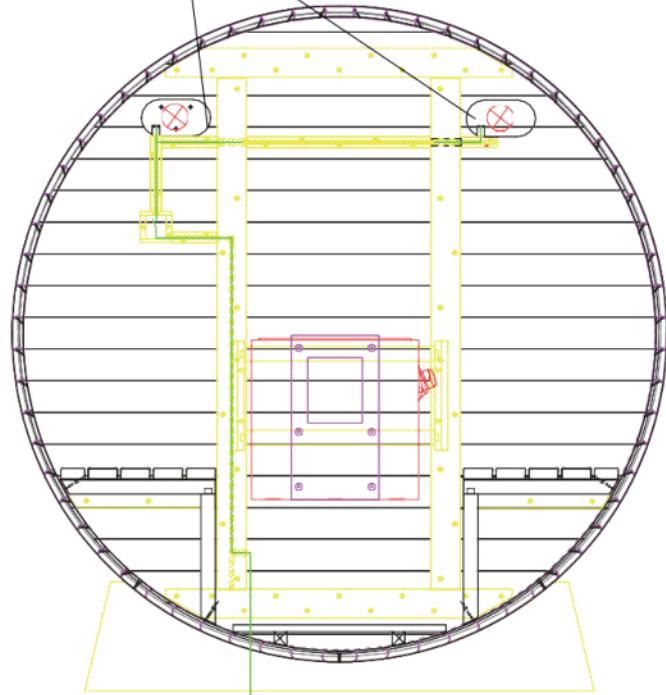
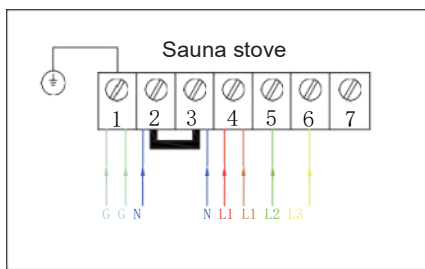
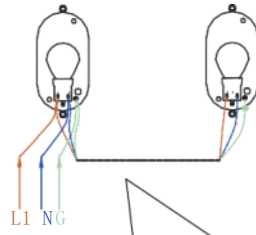

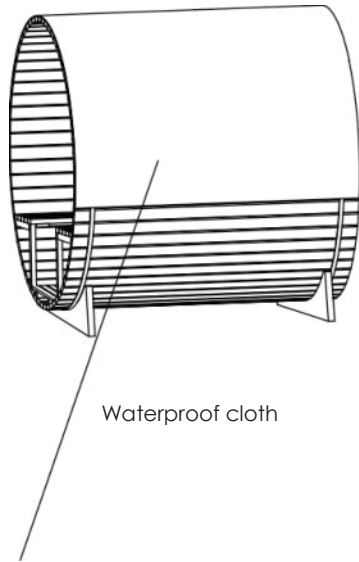

Waterproof cloth

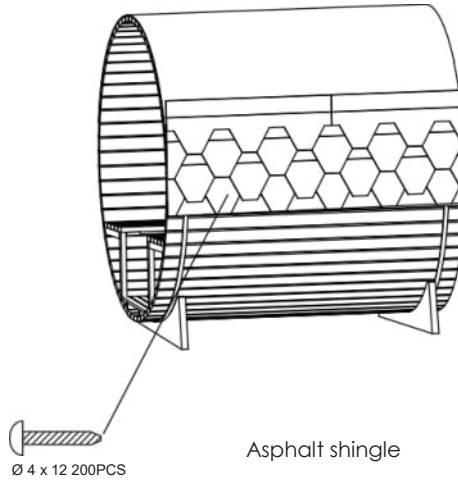

Asphalt shingle

Ø 4 x 12 200PCS

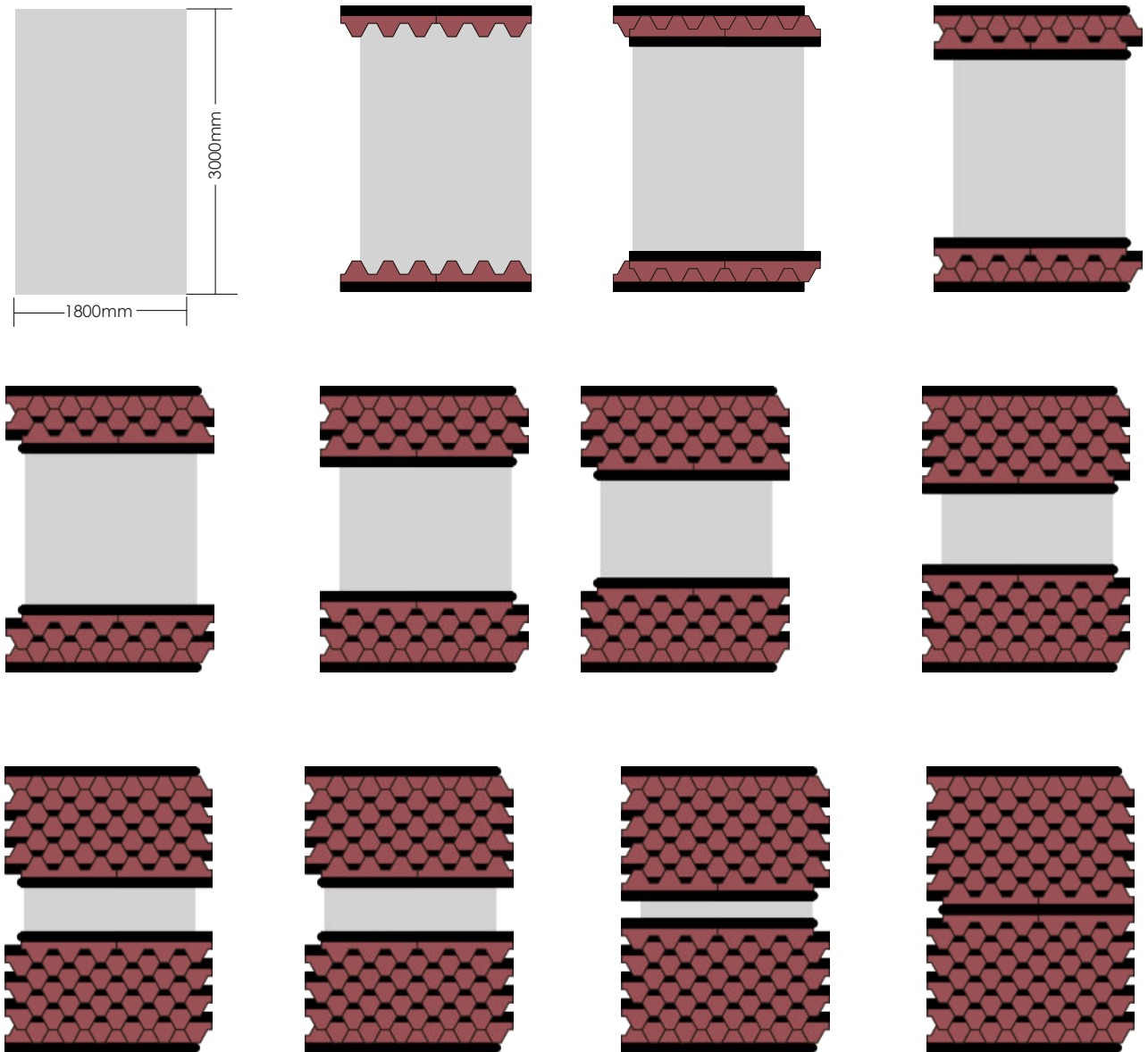
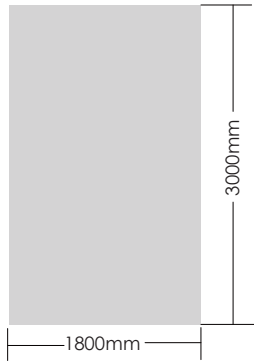

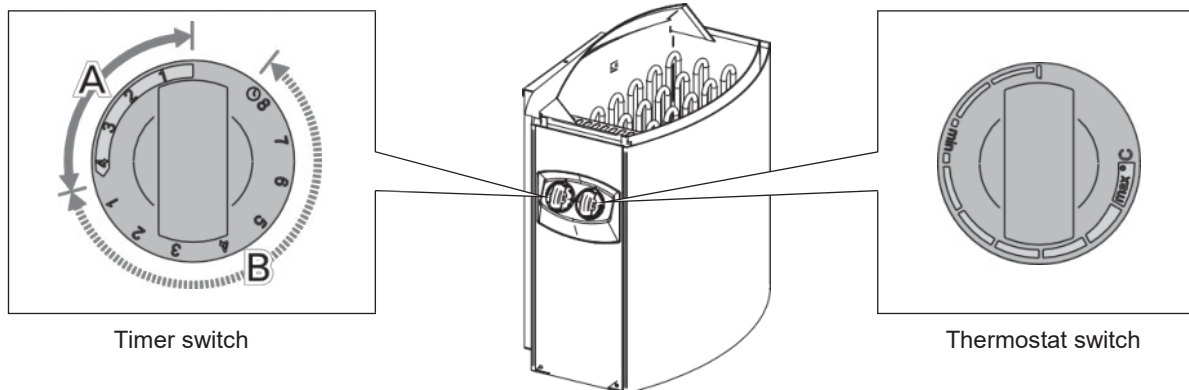

1. Heater On

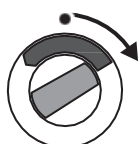

Turn the timer switch to the "on" section (section A in figure 2, 0–4 hours). The heater starts heating immediately.

2. Pre-setting Time (timed switch-on)



Turn the timer switch to the "pre-setting" section (section B in figure 2, 0–8 hours). The heater starts heating when the timer has turned the switch back to the "on" section. After this, the heater will be on for about four hours.

For more detailed information on the specific use and precautions of the sauna stove, please read the manual provided with the sauna stove.

Maintenance

Protection of wood

Brush each exterior barrel slat and apply a wood stain when full assembly to protect the wood.

This wood stain had to be renewed according to the recommendations of the product used

Maintenance

IMPORTANT :

Disconnect the cabin's power supply cable before undertaking any work.

Problems identified	Possible reasons	Solutions
Electric stove does not heat up.	Power supply cable disconnected.	Check power supply cable connection.
	The general power supply is cut.	Check that the switchboard and wall plug are working.
	Stove is overheat protected.	Refer to the electric stove manual.
Sauna light fitting no longer work.	Light cable not fully plug.	Plug the cable.
	Light is defective.	Contact your dealer.

Servicing

1. Disconnect your sauna.
2. Use a vacuum cleaner to remove dust from crevices in the woodwork.
3. Clean the cabin with a damp cotton cloth and use a small amount of soap if necessary. Rinse with a damp cloth.
4. Clean the glass with a window / glass cleaner and a soft colth.
5. Maintain the exterior of the sauna every 2 years with a suitable product.

IMPORTANT :

The wood should be treated with a protective product only on the outside of the sauna.

No treatment should be applied inside the sauna.

Do not use benzene, alcohol, chemical agents or strong detergents on the sauna since chemical products can damage the wood. Do not spray water on your sauna.

Please read the instructions provided with the sauna stove for the installation and use of the stove.

The heater may only be connected to the electrical network in accordance with the current regulations by an authorised, professional electrician.

BC45, BC60, BC80 BC45E, BC60E, BC80E, BC90E

EN

Instructions for Installation and Use of Electric Sauna Heater

DE

Gebrauchs- und Montageanleitung des Elektrosaunaofens



BC



BC-E

These instructions for installation and use are intended for the owner or the person in charge of the sauna, as well as for the electrician in charge of the electrical installation of the heater. After completing the installation, the person in charge of the installation should give these instructions to the owner of the sauna or to the person in charge of its operation. Please read the instructions for use carefully before using the heater.

The heater is designed for the heating of a sauna room to bathing temperature. It is not to be used for any other purpose.

Congratulations on your choice!

Guarantee:

- The guarantee period for heaters and control equipment used in saunas by families is two (2) years.
- The guarantee period for heaters and control equipment used in saunas by building residents is one (1) year.
- The guarantee does not cover any faults resulting from failure to comply with installation, use or maintenance instructions.
- The guarantee does not cover any faults resulting from the use of stones not recommended by the heater manufacturer.

CONTENTS

1. INSTRUCTIONS FOR USE	3
1.1. Piling of the Sauna Stones.....	3
1.1.1. Maintenance	3
1.2. Heating of the Sauna.....	4
1.3. Using the Heater	4
1.3.1. Heater On	4
1.3.2. Pre-setting Time (timed switch-on)	4
1.3.3. Heater Off.....	5
1.3.4. Setting the Temperature	5
1.4. Throwing Water on Heated Stones	5
1.5. Instructions for Bathing	6
1.6. Warnings	6
1.7. Troubleshooting	6
2. SAUNA ROOM	8
2.1. Sauna Room Structure	8
2.1.1. Blackening of the sauna walls.....	8
2.2. Sauna Room Ventilation.....	9
2.3. Heater Output.....	9
2.4. Sauna Room Hygiene.....	9
3. INSTRUCTIONS FOR INSTALLATION	10
3.1. Before Installation	10
3.2. Fastening the Heater on a Wall	11
3.3. Electrical Connections.....	12
3.3.1. Electric Heater Insulation Resistance.....	12
3.4. Installation of the Control Unit and Sensors (BC-E) ..	13
3.5. Resetting the Overheat Protector.....	13
4. SPARE PARTS	15

Diese Montage- und Gebrauchsanleitung richtet sich an den Besitzer der Sauna oder an die für die Pflege der Sauna verantwortliche Person, sowie an den für die Montage des Saunaofens zuständigen Elektromonteur. Wenn der Saunaofen montiert ist, wird diese Montage- und Gebrauchsanleitung an den Besitzer der Sauna oder die für die Pflege der Sauna verantwortliche Person übergeben. Lesen Sie vor Inbetriebnahme des Ofens die Bedienungsanleitung sorgfältig durch.

Der Ofen dient zum Erwärmen von Saunakabinen auf Saunatemperatur. Die Verwendung zu anderen Zwecken ist verboten.

Wir beglückwünschen Sie zu Ihrer guten Wahl!

Garantie:

- Die Garantiezeit für in Familiensaunen verwendete Saunaöfen und Steuergeräte beträgt zwei (2) Jahre.
- Die Garantiezeit für Saunaöfen und Steuergeräte, die in öffentlichen Saunen in Privatgebäuden verwendet werden, beträgt ein (1) Jahr.
- Die Garantie deckt keine Defekte ab, die durch fehlerhafte Installation und Verwendung oder Missachtung der Wartungsanweisungen entstanden sind.
- Die Garantie kommt nicht für Schäden auf, die durch Verwendung anderer als vom Werk empfohlener Saunaofensteine entstehen.

INHALT

1. BEDIENUNGSANLEITUNG	3
1.1. Aufschichten der Saunaofensteine.....	3
1.1.1. Wartung	3
1.2. Erhitzen der Saunakabine	4
1.3. Benutzung des Ofens.....	4
1.3.1. Ofen ein	4
1.3.2. Vorwahlzeit (zeitgesteuertes Einschalten)	4
1.3.3. Ofen aus.....	5
1.3.4. Einstellen der Temperatur.....	5
1.4. Aufguss	5
1.5. Anleitungen zum Saunen.....	6
1.6. Warnungen.....	6
1.7. Störungen	6
2. SAUNAKABINE	8
2.1. Struktur der Saunakabine	8
2.1.1. Schwärzung der Saunawände.....	8
2.2. Belüftung der Saunakabine	9
2.3. Leistungsabgabe des Ofens	9
2.4. Hygiene der Saunakabine	9
3. INSTALLATIONSANLEITUNG	10
3.1. Vor der Montage	10
3.2. Befestigung des Saunaofens an der Wand	11
3.3. Elektroanschlüsse.....	12
3.3.1. Isolationswiderstand des Elektrosaunaofens... ..	12
3.4. Anschluß des Steuergerätes und der Fühler (BC-E)..	13
3.5. Zurückstellen des Überhitzungsschutzes.....	13
4. ERSATZTEILE	15

1. INSTRUCTIONS FOR USE

1.1. Piling of the Sauna Stones

The piling of the sauna stones has a great effect on the functioning of the heater (figure 1).

Important information on sauna stones:

- The stones should be 5–10 cm in diameter.
- Use solely angular split-face sauna stones that are intended for use in a heater. Peridotite, olivine-dolerite and olivine are suitable stone types.
- **Neither light, porous ceramic "stones" nor soft soapstones should be used in the heater. They do not absorb enough heat when warmed up. This can result in damage in heating elements.**
- Wash off dust from the stones before piling them into the heater.

Please note when placing the stones:

- Do not drop stones into the heater.
- Do not wedge stones between the heating elements.
- Place the stones sparsely to ensure that air can circulate between them.
- Pile the stones so that they support each other instead of lying their weight on the heating elements.
- Do not form a high pile of stones on top of the heater.
- No such objects or devices should be placed inside the heater stone space or near the heater that could change the amount or direction of the air flowing through the heater.

1. BEDIENUNGSANLEITUNG

1.1. Aufschichten der Saunaofensteine

Die Schichtung der Ofensteine hat eine große Auswirkung auf die Effizienz des Ofens (Abb. 1).

Wichtige Informationen zu Saunaofensteinen:

- Die Steine sollten einen Durchmesser von 5–10 cm haben.
- Verwenden Sie nur spitze Saunasteine mit rauer Oberfläche, die für die Verwendung in Saunaöfen vorgesehen sind. Geeignete Gesteinsarten sind Peridotit, Olivin-Dolerit und Olivin.
- **Im Saunaofen sollten weder leichte poröse „Steine“ aus Keramik noch weiche Specksteine verwendet werden. Sie absorbieren beim Erhitzen nicht genügend Wärme, was zu einer Beschädigung der Heizelemente führen kann.**
- Die Steine sollten vor dem Aufschichten von Steinstaub befreit werden.

Beachten Sie beim Platzieren der Steine Folgendes:

- Lassen Sie die Steine nicht einfach in den Ofen fallen.
- Vermeiden Sie ein Verkeilen von Steinen zwischen den Heizelementen.
- Schichten Sie die Steine in lockerer Anordnung, so dass Luft zwischen ihnen hindurchströmen kann.
- Schichten Sie die Steine so aufeinander, dass sie nicht gegen die Heizelemente drücken.
- Schichten Sie die Steine oben auf dem Ofen nicht zu einem hohen Stapel auf.
- In der Steinkammer oder in der Nähe des Saunaofens dürfen sich keine Gegenstände oder Geräte befinden, die die Menge oder die Richtung des durch den Saunaofen führenden Luftstroms ändern.

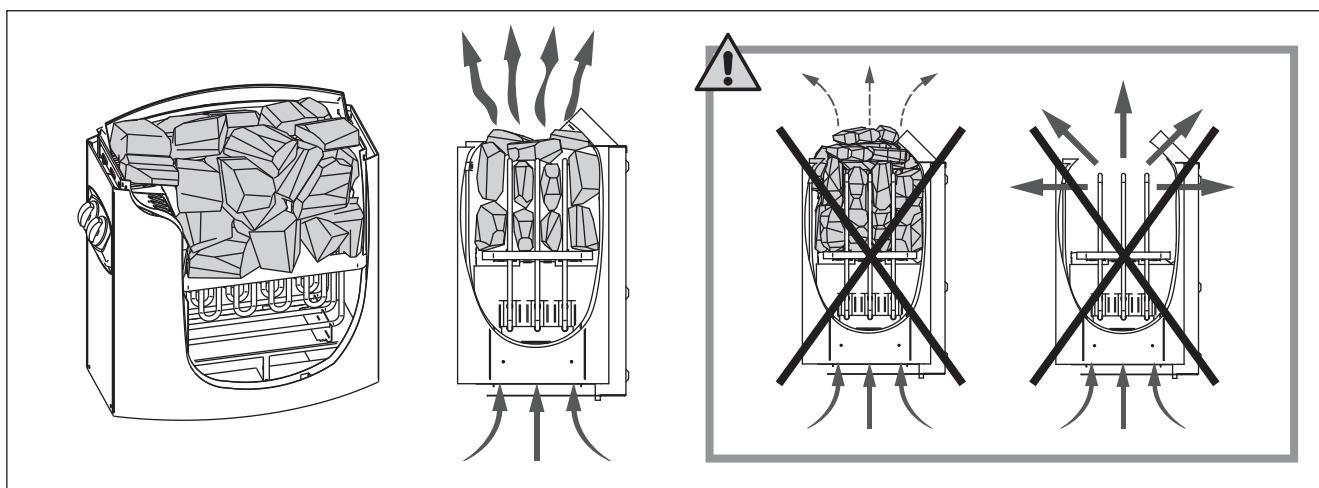

Figure 1. Piling of the sauna stones
Abbildung 1. Aufschichtung der Saunaofensteine

1.1.1. Maintenance

Due to large variation in temperature, the sauna stones disintegrate in use. Rearrange the stones at least once a year or even more often if the sauna is in frequent use. At the same time, remove any pieces of stones from the bottom of the heater and replace any disintegrated stones with new ones. By doing this, the heating capability of the heater stays optimal and the risk of overheating is avoided.

1.1.1. Wartung

Aufgrund der großen Wärmeänderungen werden die Saunasteine spröde und brüchig. Die Steine sollten mindestens einmal jährlich neu aufgeschichtet werden, bei regelmäßigem Gebrauch öfter. Bei dieser Gelegenheit entfernen Sie bitte auch Staub und Gesteinssplitter aus dem unteren Teil des Saunaofens und ersetzen beschädigte Steine. Hierdurch bleibt die Heizleistung des Ofens optimal, und das Risiko der Überhitzung wird vermieden.

1.2. Heating of the Sauna

When operating the heater for the first time, both the heater and the stones emit smell. To remove the smell, the sauna room needs to be efficiently ventilated.

If the heater output is suitable for the sauna room, it will take about an hour for a properly insulated sauna to reach the required bathing temperature (▷ 2.3.). The sauna stones normally reach the bathing temperature at the same time as the sauna room. A suitable temperature for the sauna room is about 65–80 °C.

1.3. Using the Heater

Before switching the heater on always check that there isn't anything on top of the heater or inside the given safety distance. ▷ 1.6.

- Heater models BC45, BC60 and BC80 are equipped with a timer and a thermostat. The timer is for setting the on-time for the heater and the thermostat is for setting a suitable temperature. ▷ 1.3.1.–1.3.4.
- Heater models BC45E, BC60E, BC80E and BC90E are controlled from a separate control unit. See the instructions for use of the selected control unit model.

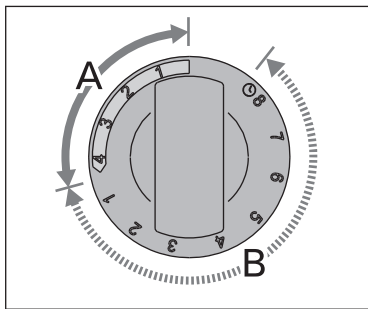

Figure 2. Timer switch
Abbildung 2. Schalter der Zeitschaltuhr

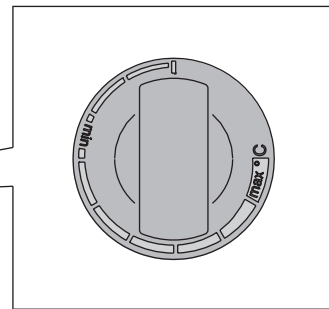
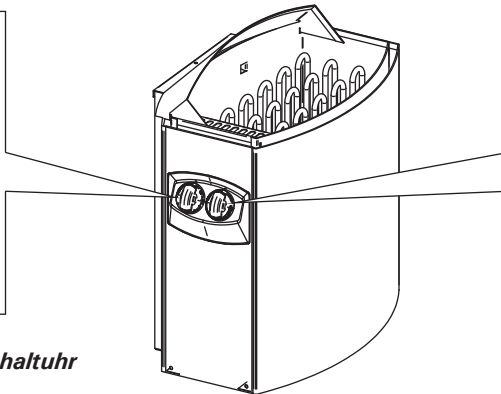

Figure 3. Thermostat switch
Abbildung 3. Thermostatschalter

1.3.1. Heater On



Turn the timer switch to the "on" section (section A in figure 2, 0–4 hours). The heater starts heating immediately.

1.3.2. Pre-setting Time (timed switch-on)



Turn the timer switch to the "pre-setting" section (section B in figure 2, 0–8 hours). The heater starts heating when the timer has turned the switch back to the "on" section. After this, the heater will be on for about four hours.

Example: You want to go walking for three hours and have a sauna bath after that. Turn the timer switch to the "pre-setting" section at number 2.

The timer starts. After two hours, the heater starts heating. Because it takes about one hour for the sauna to be heated, it will be ready for bathing after about three hours, that is, when you come back from your walk.

1.2. Erhitzen der Saunakabine

Beim ersten Erwärmen sondern sich von Saunaofen und Steinen Gerüche ab. Um diese zu beseitigen, muss die Saunakabine gründlich gelüftet werden.

Bei einer für die Saunakabine angemessenen Ofenleistung ist eine isolierte Sauna innerhalb von einer Stunde auf die erforderliche Saunatemperatur aufgeheizt (▷ 2.3.). Die Saunaofensteine erwärmen sich gewöhnlicherweise in derselben Zeit auf Aufgusstemperatur wie die Saunakabine. Die passende Temperatur in der Saunakabine beträgt etwa 65 bis 80 °C.

1.3. Benutzung des Ofens

Bitte überprüfen Sie, bevor Sie den Ofen anschalten, dass keine Gegenstände auf dem Ofen oder in unmittelbarer Nähe des Ofens liegen. ▷ 1.6.

- Die Ofenmodelle BC45, BC60 und BC80 sind mit einer Zeitschaltuhr und einem Thermostat ausgestattet. Die Zeitschaltuhr regelt die Einschaltzeit des Ofens und das Thermostat die Temperatur. ▷ 1.3.1.–1.3.4.
- Die Ofenmodelle BC45E, BC60E, BC80E und BC90E werden mit einem separaten Steuergerät bedient. Beachten Sie die mitgelieferte Bedienungsanleitung der Steuerung.

1.3.1. Ofen ein

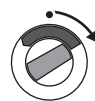

Stellen Sie den Schalter der Zeitschaltuhr in den Abschnitt "ein" (Abschnitt A in Abb. 2, 0–4 Stunden). Der Ofen beginnt sofort zu heizen.

1.3.2. Vorwahlzeit (zeitgesteuertes Einschalten)



Stellen Sie den Schalter der Zeitschaltuhr in den Abschnitt "Vorwahl" (Abschnitt B in Abb. 2, 0–8 Stunden). Der Ofen beginnt zu heizen, wenn die Zeitschaltuhr den Schalter zurück in den Abschnitt "ein" gedreht hat. Danach bleibt der Ofen etwa vier Stunden lang an.

Beispiel: Sie möchten drei Stunden lang spazieren gehen und danach ein Saunabad nehmen. Stellen Sie den Schalter der Zeitschaltuhr in den Abschnitt "Vorwahl" auf Nummer 2.

Die Zeitschaltuhr beginnt zu laufen. Nach zwei Stunden beginnt der Ofen zu heizen. Da es etwa eine Stunde dauert, bis die Sauna erhitzt ist, wird sie nach etwa drei Stunden für das Saunabad bereit sein, also dann, wenn Sie von Ihrem Spaziergang zurückkehren.

1.3.3. Heater Off



The heater switches off, when the timer turns the switch back to zero. You can switch the heater off at any time by turning the timer switch to zero yourself.

Switch the heater off after bathing. Sometimes it may be advisable to leave the heater on for a while to let the wooden parts of the sauna dry properly.

NOTE! Always check that the heater has switched off and stopped heating after the timer has turned the switch to zero.

1.3.4. Setting the Temperature

The purpose of the thermostat (figure 3) is to keep the temperature in the sauna room on a desired level. By experimenting, you can find the setting that suits you best.

Begin experimenting at the maximum position. If, during bathing, the temperature rises too high, turn the switch counter-clockwise a little. Note that even a small difference within the maximum section will change the temperature of the sauna considerably.

1.4. Throwing Water on Heated Stones

The air in the sauna room becomes dry when warmed up. Therefore, it is necessary to throw water on the heated stones to reach a suitable level of humidity in the sauna. The effect of heat and steam on people varies – by experimenting, you can find the levels of temperature and humidity that suit you best.

NOTE! The maximum volume of the ladle is 0.2 litres. If an excessive amount of water is poured on the stones, only part of it will evaporate and the rest may splash as boiling hot water on the bathers. Never throw water on the stones when there are people near the heater, because hot steam may burn their skin.

NOTE! The water to be thrown on the heated stones should meet the requirements of clean household water (table 1). Only special aromas designed for sauna water may be used. Follow the instructions given on the package.

1.3.3. Ofen aus



Der Ofen wird ausgeschaltet, wenn die Zeitschaltuhr den Schalter zurück auf null gedreht hat. Sie können den Ofen jederzeit selbst ausschalten, indem Sie den Schalter der Zeitschaltuhr auf null stellen.

Schalten Sie den Ofen nach dem Saunabad aus. Manchmal ist es ratsam, den Ofen noch eine Weile weiter laufen zu lassen, um die Holzteile der Sauna richtig trocknen zu lassen.

ACHTUNG! Vergewissern Sie sich stets, dass der Ofen ausgeschaltet ist und nicht mehr heizt, wenn die Zeitschaltuhr den Schalter zurück auf null gedreht hat.

1.3.4. Einstellen der Temperatur

Zweck des Thermostats (Abb. 3) ist es, die Temperatur in der Saunakabine auf der gewünschten Höhe zu halten. Durch Ausprobieren können Sie ermitteln, welche Einstellung für Sie am besten geeignet ist.

Beginnen Sie mit der höchsten Einstellung. Wenn die Temperatur während des Saunabades zu hoch ansteigt, drehen Sie den Schalter ein Stück gegen den Uhrzeigersinn. Beachten Sie, dass im oberen Temperaturbereich auch kleine Änderungen die Temperatur in der Sauna beträchtlich beeinflussen.

1.4. Aufguss

Die Saunaluft trocknet bei Erwärmung aus, daher sollte zur Erlangung einer angenehmen Luftfeuchtigkeit auf die heißen Steine des Saunaofens Wasser gegossen werden. Die Auswirkungen von Hitze und Dampf sind von Mensch zu Mensch unterschiedlich – durch Ausprobieren finden Sie die Temperatur- und Luftfeuchtigkeitswerte, die für Sie am besten geeignet sind.

ACHTUNG! Die Kapazität der Saunakelle sollte höchstens 0,2 l betragen. Auf die Steine sollten keine größeren Wassermengen auf einmal gegossen werden, da beim Verdampfen sonst kochend heißes Wasser auf die Badenden spritzen könnte. Achten Sie auch darauf, daß Sie kein Wasser auf die Steine gießen, wenn sich jemand in deren Nähe befindet. Der heiße Dampf könnte Brandwunden verursachen.

ACHTUNG! Als Aufgusswasser sollte nur Wasser verwendet werden, das die Qualitätsvorschriften für Haushaltswasser erfüllt (Tabelle 1). Im Aufgusswasser dürfen nur für diesen Zweck ausgewiesene Duftstoffe verwendet werden. Befolgen Sie die Anweisungen auf der Packung.

Water property Wassereigenschaft	Effect Wirkung	Recommendation Empfehlung
Humus concentration Humusgehalt	Colour, taste, precipitates Farbe, Geschmack, Ablagerungen	< 12 mg/l
Iron concentration Eisengehalt	Colour, odour, taste, precipitates Farbe, Geruch, Geschmack, Ablagerungen	< 0,2 mg/l
Hardness: most important substances are manganese (Mn) and lime, i.e. calcium (Ca). Wasserhärte: Die wichtigsten Stoffe sind Mangan (Mn) und Kalk, d.h. Kalzium (Ca).	Precipitates Ablagerungen	Mn: < 0,05 mg/l Ca: < 100 mg/l
Chlorinated water Gechlortes Wasser	Health risk Gesundheitsschädlich	Forbidden to use Darf nicht verwendet werden
Seawater Salzwasser	Rapid corrosion Rasche Korrosion	Forbidden to use Darf nicht verwendet werden

Table 1. Water quality requirements
Tabelle 1. Anforderungen an die Wasserqualität

1.5. Instructions for Bathing

- Begin by washing yourself.
- Stay in the sauna for as long as you feel comfortable.
- Forget all your troubles and relax.
- According to established sauna conventions, you must not disturb other bathers by speaking in a loud voice.
- Do not force other bathers from the sauna by throwing excessive amounts of water on the stones.
- Cool your skin down as necessary. If you are in good health, you can have a swim if a swimming place or pool is available.
- Wash yourself after bathing.
- Rest for a while and let your pulse go back to normal. Have a drink of fresh water or a soft drink to bring your fluid balance back to normal.

1.6. Warnings

- **Staying in the hot sauna for long periods of time makes the body temperature rise, which may be dangerous.**
- **Keep away from the heater when it is hot. The stones and outer surface of the heater may burn your skin.**
- **Keep children away from the heater.**
- **Do not let young, handicapped or ill people bathe in the sauna on their own.**
- **Consult your doctor about any health-related limitations to bathing.**
- **Consult your child welfare clinic about taking little babies to the sauna.**
- **Be very careful when moving in the sauna, as the platform and floors may be slippery.**
- **Never go to a hot sauna if you have taken alcohol, strong medicines or narcotics.**
- **Never sleep in a hot sauna.**
- **Sea air and a humid climate may corrode the metal surfaces of the heater.**
- **Do not hang clothes to dry in the sauna, as this may cause a risk of fire. Excessive moisture content may also cause damage to the electrical equipment.**

1.7. Troubleshooting

Note! All service operations must be done by professional maintenance personnel.

The heater does not heat.

- Check that the fuses to the heater are in good condition.
- Check that the connection cable is connected (▷ 3.3.).
- Turn the timer switch to the "on" section (▷ 1.3.1.).
- Turn the thermostat to a higher setting (▷ 1.3.4.).
- Check that the overheat protector has not gone off. The timer works but the heater does not heat. (▷ 3.5.)

The sauna room heats slowly. The water thrown on the sauna stones cools down the stones quickly.

- Check that the fuses to the heater are in good

1.5. Anleitungen zum Saunen

- Waschen Sie sich vor dem Saunen.
- Bleiben Sie in der Sauna, solange Sie es als angenehm empfinden.
- Vergessen Sie jeglichen Stress, und entspannen Sie sich.
- Zu guten Saunamanieren gehört, daß Sie Rücksicht auf die anderen Badenden nehmen, indem Sie diese nicht mit unnötig lärmigem Benehmen stören.
- Verjagen Sie die anderen auch nicht mit zu vielen Aufgüssen.
- Lassen Sie Ihre erhitzte Haut zwischendurch abkühlen. Falls Sie gesund sind, und die Möglichkeit dazu besteht, gehen Sie auch schwimmen.
- Waschen Sie sich nach dem Saunen.
- Ruhen Sie sich aus, bis Sie sich ausgeglichen fühlen. Trinken Sie klares Wasser oder einen Softdrink, um Ihren Flüssigkeitshaushalt zu stabilisieren.

1.6. Warnungen

- **Ein langer Aufenthalt in einer heißen Sauna führt zum Ansteigen der Körpertemperatur, was gefährlich sein kann.**
- **Achtung vor dem heißen Saunaofen. Die Steine sowie das Gehäuse werden sehr heiß und können die Haut verbrennen.**
- **Halten Sie Kinder vom Ofen fern.**
- **Kinder, Gehbehinderte, Kranke und Schwache dürfen in der Sauna nicht alleingelassen werden.**
- **Gesundheitliche Einschränkungen bezogen auf das Saunen müssen mit dem Arzt besprochen werden.**
- **Über das Saunen von Kleinkindern sollten Sie sich in der Mütterberatungsstelle beraten lassen.**
- **Gehen Sie nicht in die Sauna, wenn Sie unter dem Einfluß von Narkotika (Alkohol, Medikamenten, Drogen usw.) stehen.**
- **Schlafen Sie nie in einer erhitzten Sauna.**
- **Meer- und feuchtes Klima können die Metalloberflächen des Saunaofens rosten lassen.**
- **Benutzen Sie die Sauna wegen der Brandgefahr nicht zum Kleider- oder Wäschetrocknen, außerdem können die Elektrogeräte durch die hohe Feuchtigkeit beschädigt werden.**

1.7. Störungen

Achtung! Alle Wartungsmaßnahmen müssen von qualifiziertem technischem Personal durchgeführt werden.

Der Ofen wärmt nicht.

- Vergewissern Sie sich, dass die Sicherungen des Ofens in gutem Zustand sind.
- Überprüfen Sie, ob das Anschlusskabel eingesteckt ist (▷ 3.3.).
- Stellen Sie den Schalter der Zeitschaltuhr in den Abschnitt "ein" (▷ 1.3.1.).
- Stellen Sie das Thermostat auf eine höhere Einstellung (▷ 1.3.4.).
- Überprüfen Sie, ob der Überhitzungsschutz ausgelöst wurde. Die Zeitschaltuhr läuft, aber der Ofen wärmt nicht. (▷ 3.5.)

Die Saunakabine erhitzt sich zu langsam. Das auf die Saunaofensteine geworfene Wasser kühlt die Steine schnell ab.

condition.

- Check that all heating elements glow when the heater is on.
- Turn the thermostat to a higher setting (▷ 1.3.4.).
- Check that the heater output is sufficient (▷ 2.3.).
- Check the sauna stones (▷ 1.1.). Too tightly piled stones, the settling of stones with time or wrong stone type can hinder the air flow through the heater, which results in reduced heating efficiency.
- Check that the sauna room ventilation has been arranged correctly (▷ 2.2.).

The sauna room heats quickly, but the temperature of the stones remain insufficient.

Water thrown on the stones runs through.

- Turn the thermostat to a lower setting (▷ 1.3.4.).
- Check that the heater output is not too high (▷ 2.3.).
- Check that the sauna room ventilation has been arranged correctly (▷ 2.2.).

The sauna room heats unevenly.

- Check that the heater has been installed in the correct height. The heater heats the sauna best, when it is installed 100 mm from the floor. The maximum installation height is 200 mm. (▷ 3.2.)

Panel or other material near the heater blackens quickly.

- Check that the requirements for safety distances are fulfilled (▷ 3.1.).
- Check the sauna stones (▷ 1.1.). Too tightly piled stones, the settling of stones with time or wrong stone type can hinder the air flow through the heater, which may result in overheating of surrounding materials.
- Also see section 2.1.1.

The heater emits smell.

- See section 1.2.
- The hot heater may emphasize odours mixed in the air that are not, however, caused by the sauna or the heater. Examples: paint, glue, oil, seasoning.

The heater makes noise.

- BC: The timer is a mechanical device and it makes a ticking sound when it is functioning normally. If the timer ticks even when the heater is switched off, check the timer's wiring.
- Occasional bangs are most likely caused by stones cracking due to heat.
- The thermal expansion of heater parts can cause noises when the heater warms up.

- Vergewissern Sie sich, dass die Sicherungen des Ofens in gutem Zustand sind.
- Vergewissern Sie sich, dass bei eingeschaltetem Ofen alle Heizelemente glühen.
- Stellen Sie das Thermostat auf eine höhere Einstellung (▷ 1.3.4.).
- Überprüfen Sie, ob die Ofenleistung ausreichend ist (▷ 2.3.).
- Überprüfen Sie die Saunaofensteine (▷ 1.1.). Eine zu feste Stapelung der Steine, das Absetzen der Steine mit der Zeit und falsche Steinsorten können den Luftstrom durch den Ofen behindern, was zu einer verminderten Heizleistung führt.
- Vergewissern Sie sich, dass die Belüftung der Saunakabine korrekt eingerichtet wurde (▷ 2.2.).

Die Saunakabine erwärmt sich schnell, aber die Temperatur der Steine ist unzureichend. Das auf die Steine geworfene Wasser läuft durch.

- Stellen Sie das Thermostat auf eine niedrigere Einstellung (▷ 1.3.4.).
- Überprüfen Sie, ob die Ofenleistung nicht zu hoch ist (▷ 2.3.).
- Vergewissern Sie sich, dass die Belüftung der Saunakabine korrekt eingerichtet wurde (▷ 2.2.).

Die Saunakabine erhitzt sich ungleichmäßig.

- Vergewissern Sie sich, dass der Ofen in der richtigen Höhe angebracht wurde. Der Ofen kann die Sauna am besten erhitzen, wenn er 100 mm über dem Boden angebracht wird. Die maximale Montagehöhe beträgt 200 mm. (▷ 3.2.)

Panele und andere Materialien neben dem Ofen werden schnell schwarz.

- Überprüfen Sie, ob die Anforderungen für Sicherheitsabstände eingehalten werden (▷ 3.1.).
- Überprüfen Sie die Saunaofensteine (▷ 1.1.). Eine zu feste Stapelung der Steine, das Absetzen der Steine mit der Zeit und falsche Steinsorten können den Luftstrom durch den Ofen behindern, was zu einer Überhitzung der umliegenden Materialien führen kann.
- Siehe auch Abschnitt 2.1.1.

Der Ofen gibt Gerüche ab.

- Siehe Abschnitt 1.2.
- Ein heißer Ofen kann Gerüche in der Luft verstärken, die jedoch nicht durch die Sauna oder den Ofen selbst verursacht wurden. Beispiele: Farbe, Klebstoff, Öl, Würzmittel.

Der Ofen verursacht Geräusche.

- BC: Die Zeitschaltuhr ist ein mechanisches Gerät und verursacht daher ein tickendes Geräusch, wenn sie normal funktioniert. Ertönt das Ticken, obwohl der Ofen nicht eingeschaltet ist, untersuchen Sie die Anschlüsse der Zeitschaltuhr.
- Plötzliche Knall-Geräusche entstehen manchmal durch Steine, die aufgrund der Hitze platzen.
- Die Ausdehnung der Ofenteile wegen der Hitze kann bei der Erwärmung des Ofens Geräusche verursachen.

2. SAUNA ROOM

2.1. Sauna Room Structure

2. SAUNAKABINE

2.1. Struktur der Saunakabine

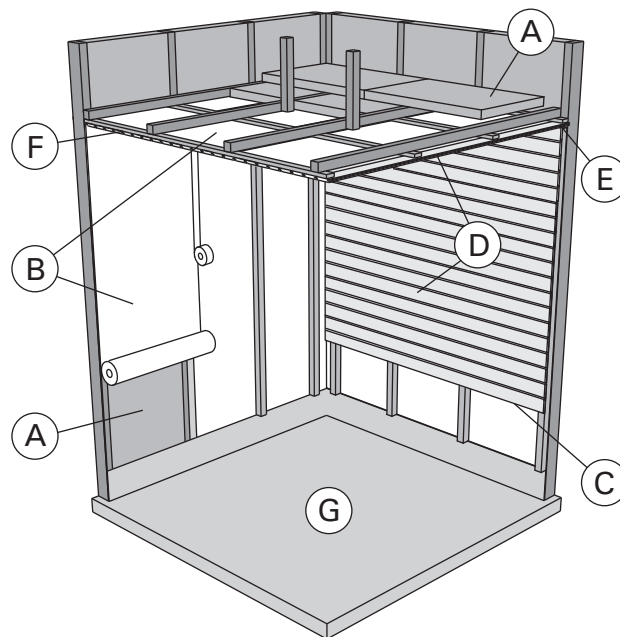

Figure 4.
Abbildung 4.

- A. Insulation wool, thickness 50–100 mm. The sauna room must be insulated carefully so that the heater output can be kept moderately low.
- B. Moisture protection, e.g. aluminium paper. Place the glossy side of the paper towards the sauna. Tape the seams with aluminium tape.
- C. Vent gap of about 10 mm between the moisture protection and panel (recommendation).
- D. Low mass 12–16 mm thick panel board. Before starting the panelling, check the electric wiring and the reinforcements in the walls required by the heater and benches.
- E. Vent gap of about 3 mm between the wall and ceiling panel.
- F. The height of the sauna is usually 2100–2300 mm. The minimum height depends on the heater (see table 2). The space between the upper bench and ceiling should not exceed 1200 mm.
- G. Use floor coverings made of ceramic materials and dark joint grouts. Particles disintegrating from the sauna stones and impurities in the sauna water may stain and/or damage sensitive floor coverings.

NOTE! Check from the fire authorities which parts of the firewall can be insulated. Flues which are in use must not be insulated.

NOTE! Light protective covers which are installed directly to the wall or ceiling may be a fire risk.

2.1.1. Blackening of the sauna walls

It is perfectly normal for the wooden surfaces of the sauna room to blacken in time. The blackening may be accelerated by

- sunlight
- heat from the heater
- protective agents on the walls (protective agents have a poor heat resistance level)
- fine particles disintegrating from the sauna stones which rise with the air flow.

- A. Isolierwolle, Stärke 50–100 mm. Die Saunakabine muss sorgfältig isoliert werden, damit der Ofen nicht zu viel Leistung erbringen muss.
- B. Feuchtigkeitsschutz, z.B. Aluminiumpapier. Die glänzende Seite des Papiers muss zur Sauna zeigen. Nähte mit Aluminiumband abdichten.
- C. Etwa 10 mm Luft zwischen Feuchtigkeitsschutz und Täfelung (Empfehlung).
- D. Leichtes, 12–16 mm starkes Täfelbrett. Vor Beginn der Täfelung elektrische Verkabelung und für Ofen und Bänke benötigte Verstärkungen in den Wänden überprüfen.
- E. Etwa 3 mm Luft zwischen Wand und Deckentäfelung.
- F. Die Höhe der Sauna ist normalerweise 2100–2300 mm. Die Mindesthöhe hängt vom Ofen ab (siehe Tabelle 2). Der Abstand zwischen oberer Bank und Decke sollte höchstens 1200 mm betragen.
- G. Bodenabdeckungen aus Keramik und dunkle Zementschlämme verwenden. Aus den Saunasteinen entweichende Partikel und Verunreinigungen im Wasser können sensible Böden verfärben oder beschädigen.

ACHTUNG! Fragen Sie die Behörden, welcher Teil der feuerfesten Wand isoliert werden kann. Rauchfänge, die benutzt werden, dürfen nicht isoliert werden.

ACHTUNG! Leichte, direkt an Wand oder Decke angebrachte Schutzabdeckungen sind ein Brandrisiko.

2.1.1. Schwärzung der Saunawände

Es ist ganz normal, wenn sich die Holzoberflächen einer Sauna mit der Zeit verfärben. Die Schwärzung wird beschleunigt durch

- Sonnenlicht
- Hitze des Ofens
- Täfelungsschutz an den Wänden (mit geringem Hitzewiderstand)
- Feinpartikel, die aus den zerfallenden Saunasteinen in die Luft entweichen.

2.2. Sauna Room Ventilation

The air in the sauna room should change six times per hour. Figure 5 illustrates different sauna room ventilation options.

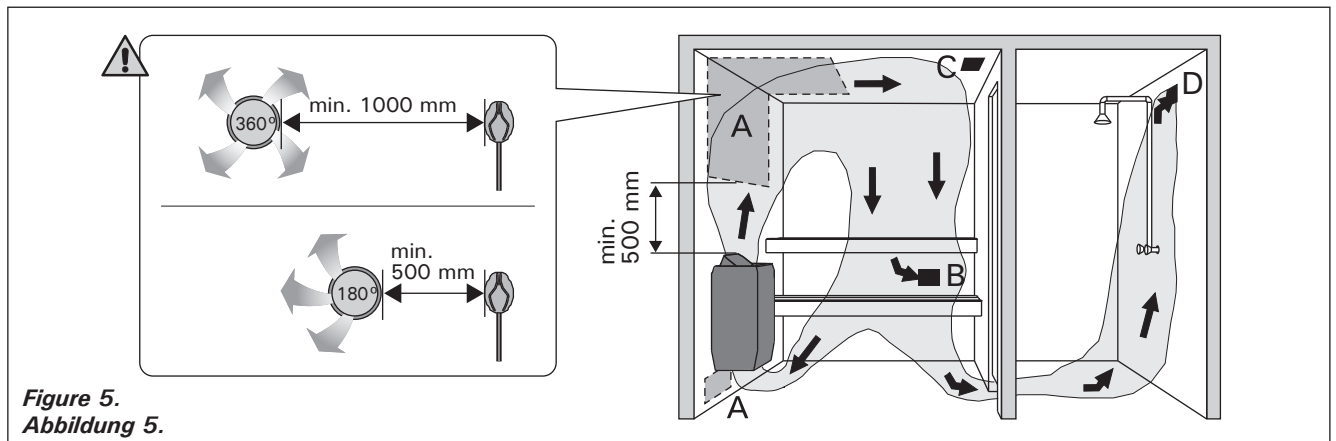

Figure 5.
Abbildung 5.

- A. Supply air vent location. If mechanical exhaust ventilation is used, place the supply air vent above the heater. If gravity exhaust ventilation is used, place the supply air vent below or next to the heater. The diameter of the supply air pipe must be 50–100 mm. **BC-E: Do not place the supply air vent so that the air flow cools the temperature sensor (see the temperature sensor installation instructions in the control unit installation instructions)!**
- B. Exhaust air vent. Place the exhaust air vent near the floor, as far away from the heater as possible. The diameter of the exhaust air pipe should be twice the diameter of the supply air pipe.
- C. Optional vent for drying (closed during heating and bathing). The sauna can also be dried by leaving the door open after bathing.
- D. If the exhaust air vent is in the washroom, the gap underneath the sauna door must be at least 100 mm. Mechanical exhaust ventilation is mandatory.

2.3. Heater Output

When the walls and ceiling are covered with panels and insulation behind the panels is adequate, the heater output is defined according to the volume of the sauna. Non-insulated walls (brick, glass block, glass, concrete, tile, etc.) increase the need for heater output. Add 1,2 m³ to the volume of the sauna for each non-insulated wall square meter. For example, a 10 m³ sauna room with a glass door equals the output requirement of about a 12 m³ sauna room. If the sauna room has log walls, multiply the sauna's volume by 1,5. Choose the correct heater output from table 2.

2.4. Sauna Room Hygiene

Bench towels should be used during bathing to prevent sweat from getting onto the benches.

The benches, walls and floor of the sauna should be washed thoroughly at least every six months. Use a scrubbing brush and sauna detergent.

Wipe dust and dirt from the heater with a damp cloth. Remove lime stains from the heater using a 10% citric acid solution and rinse.

2.2. Belüftung der Saunakabine

Die Saunaluft sollte sechsmal pro Stunde ausgetauscht werden. Abb. 5 zeigt verschiedene Optionen der Saunabelüftung.

- A. Luftzufuhr. Bei mechanischer Entlüftung Luftzufuhr über dem Ofen anbringen. Bei Schwerkraftentlüftung Luftzufuhr unter oder neben dem Ofen anbringen. Der Durchmesser des Luftzufuhrrohres muss 50–100 mm betragen. **BC-E: Luftzufuhr nicht so anbringen, dass sie den Temperaturfühler abkühlt (zur Anbringung des Temperaturfühlers siehe Installationsanweisungen des Steuergeräts)!**
- B. Entlüftung. Entlüftung in Bodennähe anbringen, so weit weg vom Ofen wie möglich. Der Durchmesser des Entlüftungsrohres sollte doppelt so groß sein wie bei der Luftzufuhr.
- C. Optionale Lüftung zum Trocknen (während Heizung und Bad geschlossen). Die Sauna kann auch durch die offene Tür getrocknet werden.
- D. Wenn die Entlüftung im Waschraum liegt, muss die Lücke unter der Saunatur mindestens 100 mm betragen. Mechanische Entlüftung ist Pflicht.

2.3. Leistungsabgabe des Ofens

Wenn Wand und Decke vertäfelt und ausreichend isoliert sind, richtet sich die Leistungsabgabe des Ofens nach dem Volumen der Sauna. Nicht isolierte Wände (Stein, Glasbausteine, Glas, Beton, Kacheln) erhöhen die benötigte Ofenleistung. Jeder Quadratmeter nicht isolierter Wand entspricht 1,2 m³ mehr Saunavolumen. Eine 10 m³ große Saunakabine mit Glastür z.B. entspricht in der Leistungsabgabe einer 12 m³ großen Sauna. Bei Balkenwänden Saunavolumen mit 1,5 multiplizieren. Korrekte Leistungsabgabe des Ofens aus Tabelle 2 wählen.

2.4. Hygiene der Saunakabine

Liegetücher benutzen, um die Bänke vor Schweiß zu schützen.

Bänke, Wände und Boden der Sauna mindestens alle sechs Monate waschen. Bürste und Saunareinigungsmittel verwenden.

Staub und Schmutz vom Ofen mit feuchtem Tuch abwischen. Kalkablagerungen am Ofen mit 10 % Zitronensäure entfernen und spülen.

3. INSTRUCTIONS FOR INSTALLATION

3.1. Before Installation

Before installing the heater, study the instructions for installation. Check the following points:

- Is the output and type of the heater suitable for the sauna room? **The cubic volumes given in table 2 should be followed.**
- Is the supply voltage suitable for the heater?
- The location of the heater fulfils the minimum requirements concerning safety distances given in fig. 6 and table 2.

It is absolutely necessary to install the heater according to these values. Neglecting them causes a risk of fire. Only one electrical heater may be installed in the sauna room.

3. INSTALLATIONSANLEITUNG

3.1. Vor der Montage

Bevor Sie den Saunaofen installieren, lesen Sie die Montageanleitung und überprüfen Sie folgende Dinge:

- Ist der zu montierende Saunaofen in Leistung und Typ passend für die Saunakabine? **Die Rauminhaltswerte in Tabelle 2 dürfen weder über noch unterschritten werden.**
- Ist die Netzspannung für den Saunaofen geeignet?
- Der Montageort des Ofens erfüllt die in Abbildung 6 und Tabelle 2 angegebenen Sicherheitsmindestabstände.

Diese Abstände müssen unbedingt eingehalten werden, da ein Abweichen Brandgefahr verursacht. In einer Sauna darf nur ein Saunaofen installiert werden.

Heater Ofen	Output Leistung	Sauna room Saunakabine			Electrical connections Elektroanschlüsse				
		Cubic vol. Rauminhalt		Height Höhe	400 V 3N~		230 V 1N~		To sensor (BC-E) An Fühler (BC-E)
Model and dimensions/ Modell und Maße		min. m ³	max. m ³	min. mm	Connecting cable Anschlusskabel	Fuse Sicherung	Connecting cable Anschlusskabel	Fuse Sicherung	
Width/Breite • BC 480 mm • BC-E 450 mm Depth/Tiefe 310 mm Height/Höhe 540 mm Weight/Gewicht 11 kg Stones/Steine max. 20 kg	kW				mm ²	A	mm ²	A	mm ²
BC45/BC45E	4,5	3	6	1900	5 x 1,5	3 x 10	3 x 2,5	1 x 20	4 x 0,25
BC60/BC60E	6,0	5	8	1900	5 x 1,5	3 x 10	3 x 2,5	1 x 35	4 x 0,25
BC80/BC80E	8,0	7	12	1900	5 x 2,5	3 x 16	3 x 6	1 x 35	4 x 0,25
BC90E	9,0	8	14	1900	5 x 2,5	3 x 16	3 x 10	1 x 50	4 x 0,25

Table 2. Installation details

Tabelle 2. Montageinformationen

The heater can be mounted in a recess with a minimum height of 1900 millimetres.

Der Saunaofen kann in einer Wandnische angebracht werden, deren Höhe min. 1900 mm beträgt.

	A min. from side to wall, upper platform or rail von der Seitenfläche zur Wand, zur oberen Bank oder zum oberen Geländer	B min.	C min. from front surface to upper platform or rail von der Vorderfläche zur oberen Bank oder zum oberen Geländer
BC45/BC45E	35	20	35
BC60/BC60E	50	30	50
BC80/BC80E	100	30	80
BC90E	120	40	100

Figure 6. Safety distances (all dimensions in millimeters)

Abbildung 6. Sicherheitsmindestabstände (alle Abmessungen in Millimetern)

3.2. Fastening the Heater on a Wall

See figure 7.

1. Remove both cardboard covers before installation.
2. Fasten the wall-mounting rack on the wall by using the screws which come with the rack.
NOTE! There must be a support, e.g. a board, behind the panel, so that the fastening screws can be screwed into a thicker wooden material than the panel. If there are no boards behind the panel, the boards can also be fastened on the panel.
3. The right- or left-handedness of the heater can be changed by installing it to the rack correspondingly. Make sure the clip fastens in the hole properly.
4. Lift the heater to the rack on the wall so that the fastening hooks of the lower part of the rack go behind the edge of the heater body. Lock the edge of the heater onto the rack by a screw.

3.2. Befestigung des Saunaofens an der Wand

Siehe Abbildung 7.

1. Beide Schutzpappen vor der Montage entfernen!
2. Befestigen Sie das Montagegestell mit den dazu gelieferten Schrauben an der Wand.
ACHTUNG! An den Stellen, an denen die Befestigungsschrauben angebracht werden, muss sich hinter den Paneelen als Stütze z.B. ein Brett befinden, in dem die Schrauben fest sitzen. Falls sich hinter den Paneelen keine Bretter befinden, können diese auch vor den Paneelen angebracht werden.
3. Der Saunaofen kann zur Bedienung durch Rechts- oder Linkshänder unterschiedlich an der Wand montiert werden. Versichere, dass die Befestigungs-Ösen richtig dafür vorgesehene Aufhängung sitzen.
4. Heben Sie den Saunaofen so auf das Gestell an der Wand, daß die Befestigungshaken unten am Gestell hinter den Rand des Saunaofenrumpfes kommen. Schrauben Sie den oberen Rand des Saunaofens am Montagegestell fest.

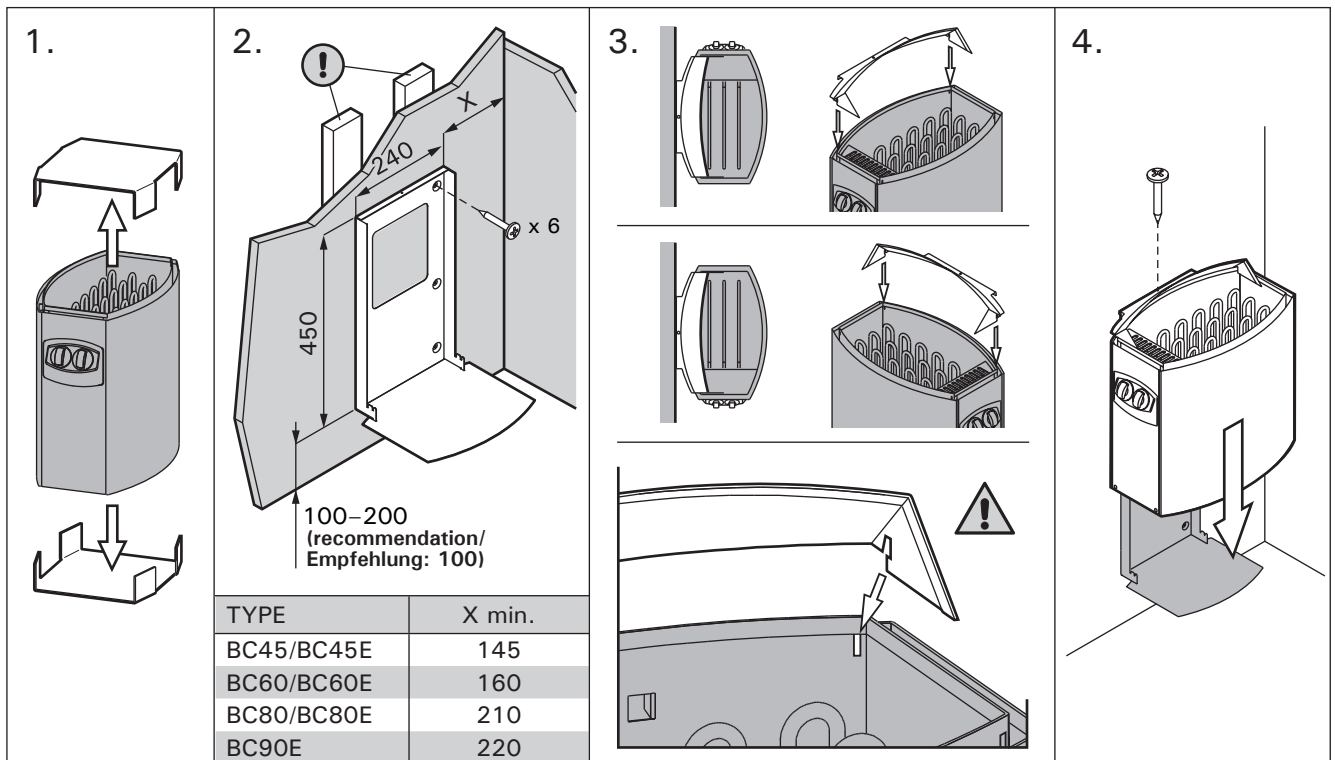

Figure 7. Fastening the heater on a wall (all dimensions in millimeters)
Abbildung 7. Befestigung des Saunaofens an der Wand (alle Abmessungen in Millimetern)

3.3. Electrical Connections

The heater may only be connected to the electrical network in accordance with the current regulations by an authorised, professional electrician.

- The heater is semi-stationarily connected to the junction box (figure 8: A) on the sauna wall. The junction box must be splash-proof, and its maximum height from the floor must not exceed 500 mm.
- The connecting cable (figure 8: B) must be of rubber cable type H07RN-F or its equivalent. **NOTE! Due to thermal embrittlement, the use of PVC-insulated wire as the connecting cable of the heater is forbidden.**
- If the connecting and installation cables are higher than 1000 mm from the floor in the sauna or inside the sauna room walls, they must be able to endure a minimum temperature of 170 °C when loaded (for example, SSJ). Electrical equipment installed higher than 1000 mm from the sauna floor must be approved for use in a temperature of 125 °C (marking T125).
- In addition to supply connectors, the BC heaters are equipped with a connector (P), which makes the control of the electric heating possible (figure 10). Voltage control is transmitted from the heater when it is switched on. The control cable for electrical heating is brought directly into the junction box of the heater, and from there to the terminal block of the heater along a rubber cable with the same cross-section area as that of the connecting cable.
- **When closing the cover of the connection box make sure that the upper edge of the cover is placed correctly.** If the upper edge is misplaced water can enter the connection box. Figure 8.

3.3. Elektroanschlüsse

Der Anschluss des Saunaofens an das Stromnetz darf nur von einem zugelassenen Elektromonteur unter Beachtung der gültigen Vorschriften ausgeführt werden.

- Der Saunaofen wird halbfest an die Klemmdose (Abb. 8: A) an der Saunawand befestigt. Die Klemmdose muß spritzwasserfest sein und darf höchstens 500 mm über dem Fußboden angebracht werden.
- Als Anschlusskabel (Abb. 8: B) wird ein Gummikabel vom Typ H07RN-F oder ein entsprechendes Kabel verwendet. **ACHTUNG! PVC-isolierte Kabel dürfen wegen ihrer schlechten Hitzebeständigkeit nicht als Anschlusskabel des Saunaofens verwendet werden.**
- Falls der Anschluss oder die Montagekabel höher als in 1000 mm Höhe über dem Boden in die Sauna oder die Saunawände münden, müssen sie belastet mindestens eine Temperatur von 170 °C aushalten (z.B. SSJ). Elektrogeräte, die höher als 1000 mm vom Saunaboden angebracht werden, müssen für den Gebrauch bei 125 °C Umgebungstemperatur zugelassen sein (Vermerk T125).
- Die BC-Saunaöfen sind zusätzlich zum Netzanschluss mit einer Klemme (P) ausgestattet, welche die Möglichkeit zur Steuerung der Elektroheizung bietet (Abb. 10). Der Ofen übernimmt mit dem Einschalten die Spannungsregelung. Das Steuerungskabel für die Elektroheizung wird direkt zur Klemmdose des Saunaofens gelegt und von dort aus durch ein Gummikabel der gleichen Stärke weiter zur Reihenklemme des Saunaofens geleitet.
- **Achten Sie beim Schließen des Deckels des Anschlusskastens darauf, dass sich der Deckel vollständig verschließt.** Wenn der Deckel nicht richtig sitzt, kann Wasser in den Anschlusskasten laufen. Abbildung 8.

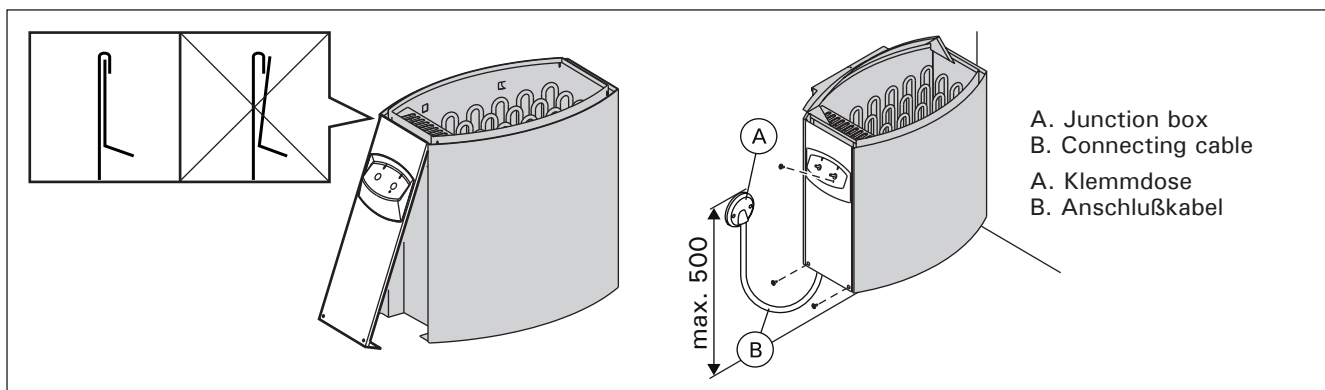

Figure 8. Closing the cover of the connection box (all dimensions in millimeters)
Abbildung 8. Das Verschließen des Anschlusskastens (alle Abmessungen in Millimetern)

3.3.1. Electric Heater Insulation Resistance

When performing the final inspection of the electrical installations, a "leakage" may be detected when measuring the heater's insulation resistance. The reason for this is that the insulating material of the heating elements has absorbed moisture from the air (storage, transport). After operating the heater for a few times, the moisture will be removed from the heating elements.

Do not connect the power feed for the heater through the RCD (residual current device)!

3.3.1. Isolationswiderstand des Elektrosaunaofens

Bei der Endkontrolle der Elektroinstallationen kann bei der Messung des Isolationswiderstandes ein "Leck" auftreten, was darauf zurückzuführen ist, daß Feuchtigkeit aus der Luft in das Isolationsmaterial der Heizwiderstände eingetreten ist (bei Lagerung und Transport). Die Feuchtigkeit entweicht aus den Widerständen nach zwei Erwärmungen.

Schalten Sie den Netzstrom des Elektrosaunaofens nicht über den Fehlerstromschutzschalter ein!

3.4. Installation of the Control Unit and Sensors (BC-E)

The control unit includes detailed instructions for fastening the unit on the wall. Install the temperature sensor on the wall of the sauna room above the heater. It should be installed on the lateral centre line of the heater, 100 mm downwards from the ceiling. Figure 6.

Do not place the supply air vent so that the air flow cools the temperature sensor. Figure 5.

3.5. Resetting the Overheat Protector

If the temperature of the sauna room becomes dangerously high, the overheat protector will permanently cut off the supply of the heater. The overheat protector can be reset after the heater has cooled down.

BC

The reset button is located inside the heater's connection box (figure 9). **Only persons authorised to carry out electrical installations can reset the overheat protector.**

Prior to pressing the button, the cause of the fault must be found.

- Are the stones crumbled and pressed together?
- Has the heater been on for a long time while unused?
- Is the sensor of the thermostat out of place or broken?
- Has the heater been banged or shaken?

BC-E

See the installation instructions for control unit.

3.4. Anschluß des Steuergerätes und der Fühler (BC-E)

In Verbindung mit dem Steuergerät werden genauere Anweisungen zu dessen Befestigung an der Wand gegeben. Der Temperaturfühler wird an der Saunawand oberhalb des Saunaofens, 100 mm unterhalb der Decke auf der Achse in Breitenrichtung des Saunaofens angebracht. Abbildung 6.

Luftzufuhr nicht so anbringen, dass sie den Temperaturfühler abkühlt. Abbildung 5.

3.5. Zurückstellen des Überhitzungsschutzes

Wenn die Temperatur in der Saunakabine gefährlich stark ansteigt, unterbricht der Überhitzungsschutz die Stromzufuhr zum Ofen permanent. Der Überhitzungsschutz kann nach Abkühlen des Ofens zurückgesetzt werden.

BC

Der Rücksetzknopf befindet sich im Anschlussgehäuse des Ofens (Abb. 9). **Nur eine zu Elektroinstallationen befugte Person darf diese Arbeit ausführen.**

Vor Betätigung des Knopfes muß die Ursache der Fehlfunktion festgestellt werden:

- Sind die Steine im Saunaofen verkeilt oder spröde?
- War der Saunaofen lange angeschaltet und wurde nicht benutzt?
- Ist der Thermostatfühler an einem falschen Platz oder defekt?
- War der Saunaofen starken Stößen ausgesetzt?

BC-E

Siehen Sie Gebrauchs- und Montageanleitung des Steuergeräts.

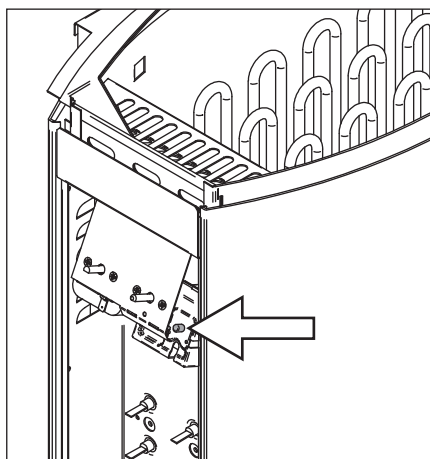

Figure 9. Reset button for overheat protector
Abbildung 9. Rücksetzknopf des Überhitzungsschutzes

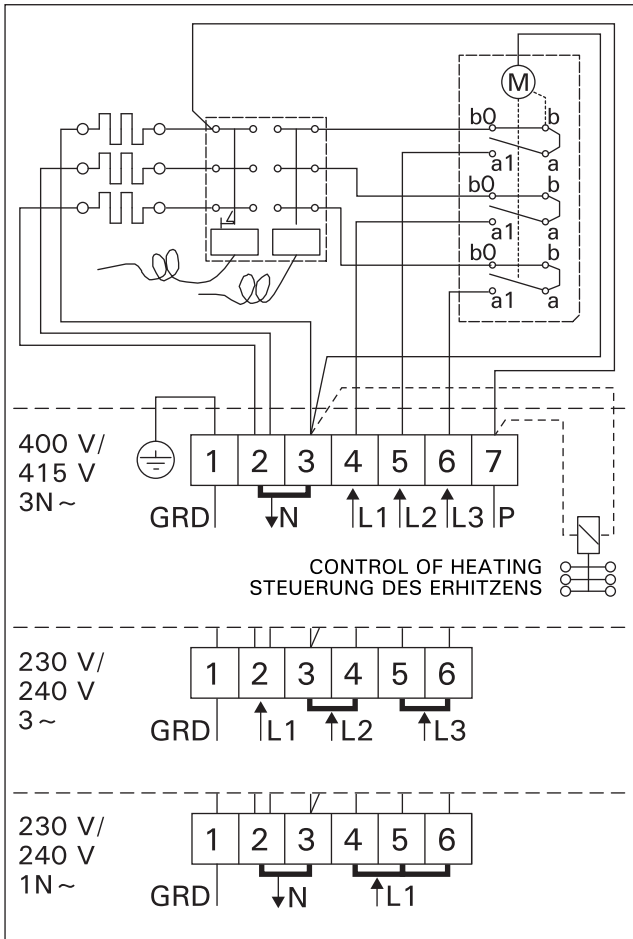

Figure 10. Electrical connections of BC heater
Abbildung 10. Elektroanschlüsse des Saunaofens BC

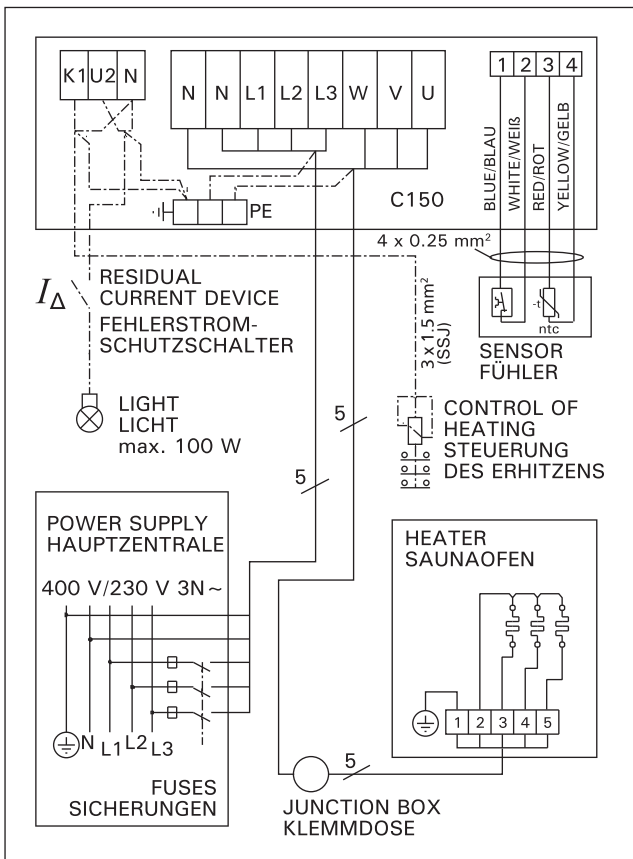

Figure 12a. 3-phase electrical connections of control unit C150 and BC-E heater
Abbildung 12a. 3-phasiger Elektroanschlüsse das Steuergerät C150 und des Saunaofens BC-E

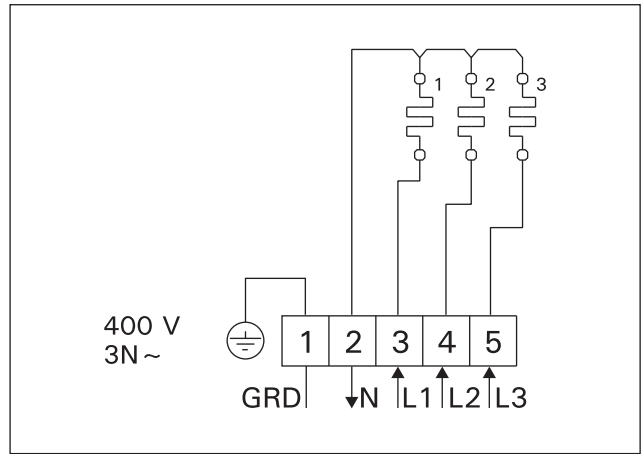

Figure 11. Electrical connections of BC-E heater
Abbildung 11. Elektroanschlüsse des Saunaofens BC-E

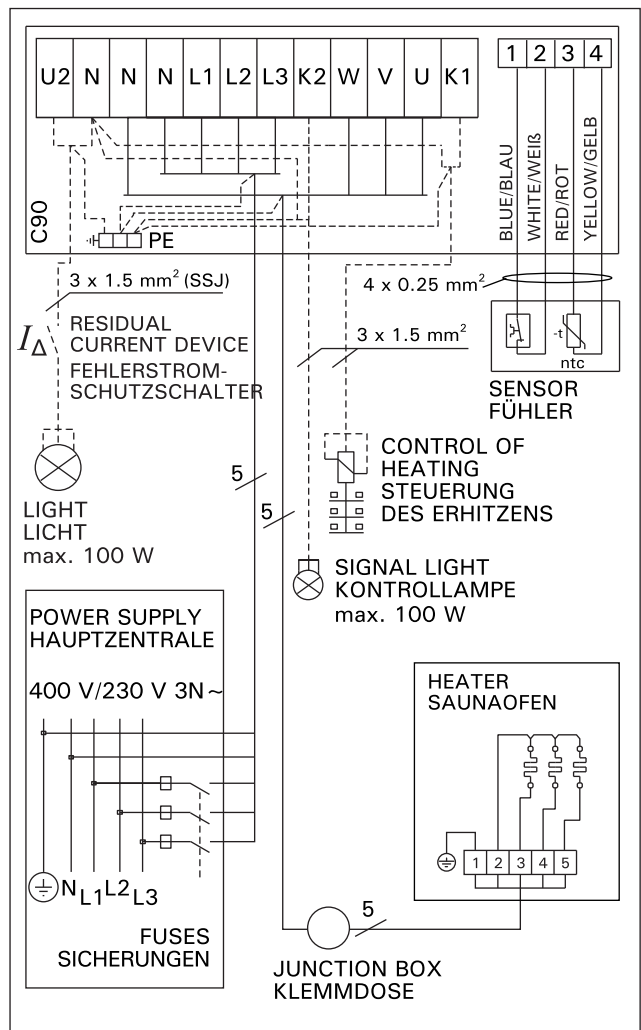
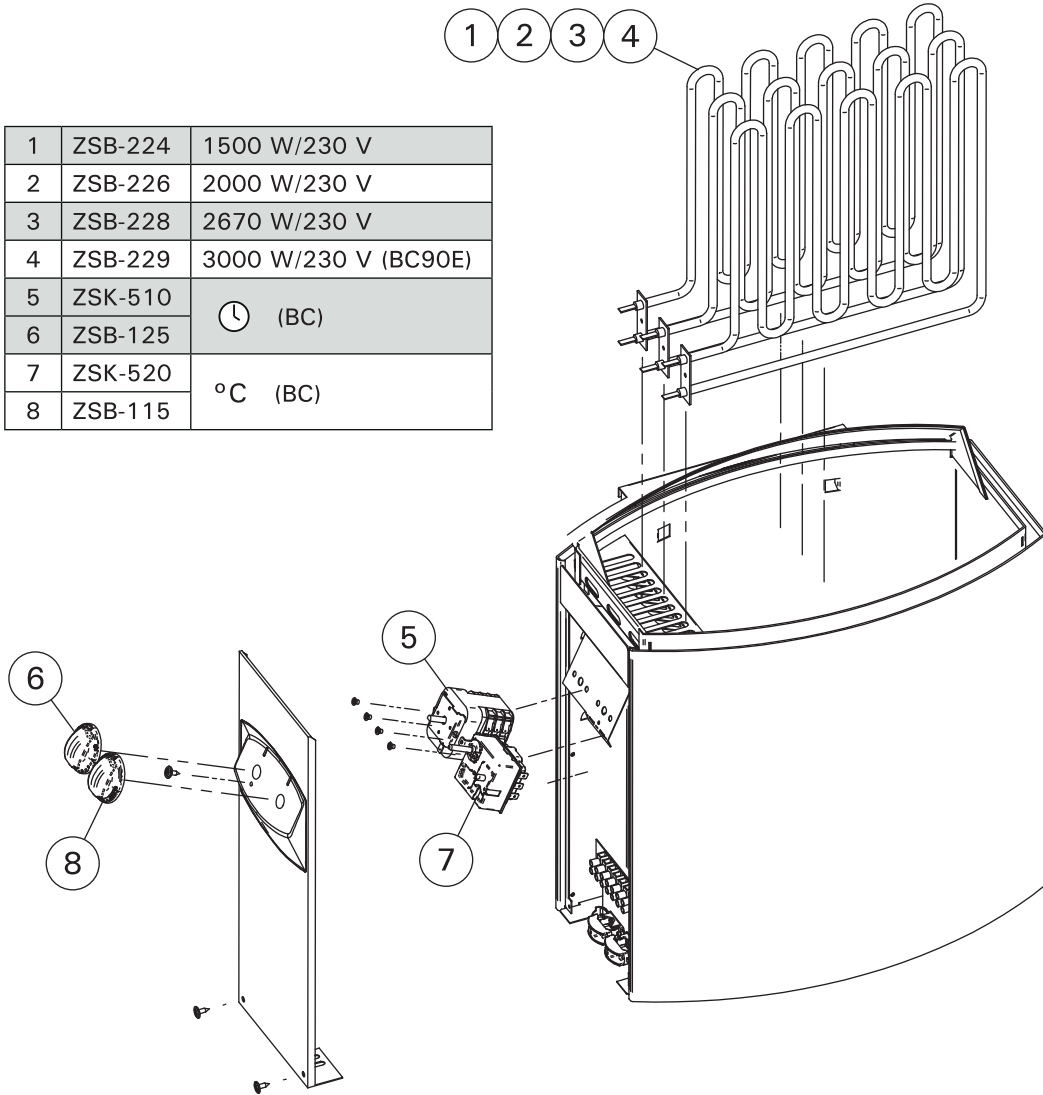

Figure 12b. 3-phase electrical connections of control unit C90 and BC-E heater
Abbildung 12b. 3-phasiger Elektroanschlüsse das Steuergerät C90 und des Saunaofens BC-E

4. SPARE PARTS

4. ERSATZTEILE

1	ZSB-224	1500 W/230 V
2	ZSB-226	2000 W/230 V
3	ZSB-228	2670 W/230 V
4	ZSB-229	3000 W/230 V (BC90E)
5	ZSK-510	⌚ (BC)
6	ZSB-125	
7	ZSK-520	°C (BC)
8	ZSB-115	



HARVIA

Harvia Oy
 PL12
 40951 Muurame
 Finland
www.harvia.fi

Инструкции за монтаж и употреба

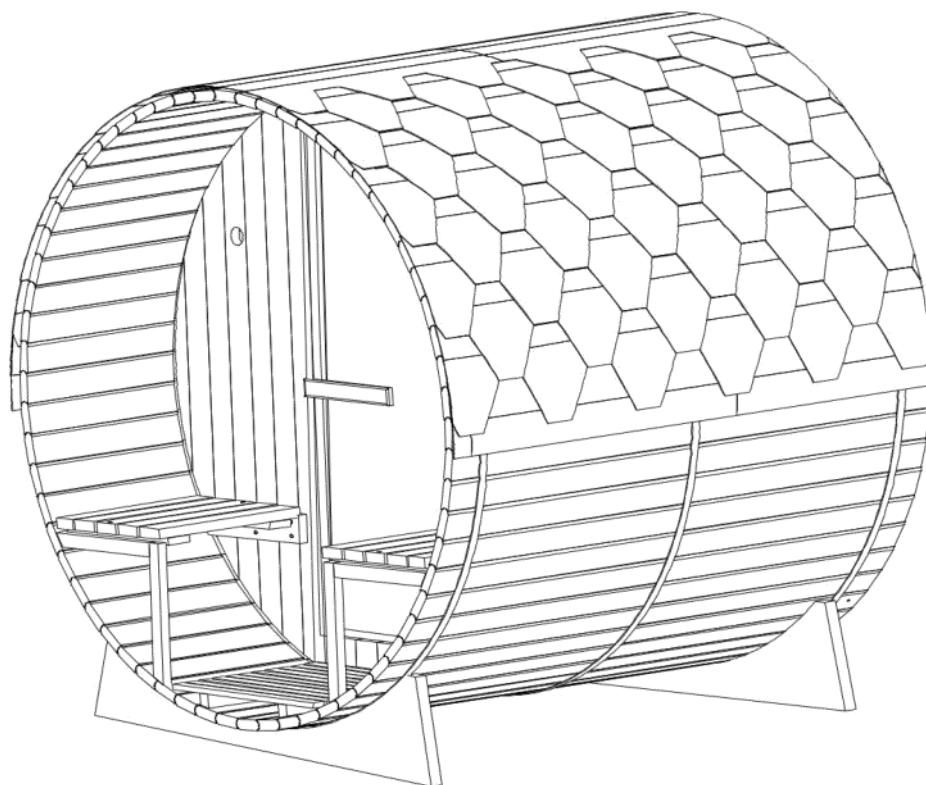

Поради непрекъснатото усъвършенстване на продукта - продуктът, илюстриран в това ръководство, може леко да се различава от действителния продукт.

Препоръки

Прочетете внимателно това ръководство, преди да използвате вашата сауна за първи път.

Препоръчваме ви да го съхранявате на сигурно място, за да можете да го използвате отново в бъдеще.

- Дървото е жив елемент. За да се запази първоначалният му вид, е важно външната страна на дървото да се третира срещу влага.
- Поставете сауната върху идеално равна и твърда повърхност.
- Не използвайте течни почистващи препарати. Преди почистване изключете сауната и използвайте влажна кърпа.
- Защитете захранващия кабел на сауната, така че да не бъде смачкан или прищипан.
- Преди да смените определени компоненти, уверете се, че те са посочени от производителя или имат същите свойства като оригиналните части. Неправилната подмяна може да причини пожар, късо съединение или повреда на сауната. Горещо препоръчваме наемането на квалифициран техник.
- За да избегнете риска от изгаряне или токов удар, не използвайте метални инструменти.
- В сауната не могат да влизат животни.
- Не оставяйте сауната включена без надзор.
- Не оставяйте сауната включена за повече от 3 часа без изключване, за да избегнете повреда на устройството. След 3 часа непрекъсната употреба изключете сауната за поне един час.
- Препоръчваме да не поставяте заключваща система на вратата на сауната.
- Проверете дали електронните части са правилно свързани, преди да свържете вашата сауна към електрическата мрежа.

Сигурност

ВАЖНО! Моля, прочетете внимателно инструкциите за безопасност, преди да настроите и използвате вашата сауна. Инструкциите са важни за вашата безопасност, така че, моля, спазвайте ги стриктно.

Бъдете нащрек за хипертермия, топлинен удар или топлинно изтощение, които могат да бъдат причинени или влошени от неспазване на инструкциите за безопасност. Симптомите включват треска, ускорен сърдечен ритъм, замаяност, припадък, летаргия и изтръпване в цялото или в части от тялото. Последниците са: намалено усещане за топлина, непознаване на непосредствената опасност, загуба на съзнание.

Сауната не може да бъде използвана от:

- Деца под 6 години.
- Хора със силни реакции към слънчева светлина.
- Възрастни хора или хора с увреждания.
- Хора с предшестващи медицински състояния като сърдечни заболявания, високо или ниско кръвно налягане, нарушения на кръвообращението или диабет без предварителен медицински съвет.
- Бременни жени. Прекомерната температура може да застраши плода.
- Хора, страдащи от дехидратация, открити рани, очни заболявания, изгаряния или слънчев удар.

Деца на възраст от 6 до 16 години могат да използват сауната, при условие че са постоянно наблюдавани от отговорен възрастен и температурата не надвишава 60°C. При здравословни проблеми, медикаменти или наранявания на мускулите и връзките можете да използвате сауната само след предварителна консултация с лекар и неговото одобрение. Ако имате хирургически импланти, не трябва да използвате сауната, без първо да се консултирате с лекар и да получите неговото/нейното съгласие. Не използвайте сауната след усилена дейност. Изчакайте 30 минути тялото ви да се охлади. Не прекарвайте повече от 40 минути наведнъж в сауната. Не употребявайте алкохол или наркотици преди или по време на сесията. Не спете в сауната, когато се използва. За да избегнете риска от прегряване, свържете вашата сауна към достатъчно мощен контакт и не свързвайте други електрически уреди към същия контакт.

За да избегнете риска от токов удар или повреда на сауната, тя не трябва да се използва:

- По време на гръмотевична буря.
- Ако електрическият кабел е повреден, той трябва да бъде заменен от квалифицирано лице.
- Ако захранващият кабел прегрее, той трябва да бъде проверен от квалифицирано лице.
- Ако трябва да смените електрическа крушка, изчакайте сауната да се изключи и да се охлади.

Изсушете ръцете си, преди да включите или изключите захранването.

Никога не работете с мокри ръце или крака.

Не включвайте или изключвайте бързо захранването или отоплението, тъй като това може да повреди електрическата система.

Не се опитвайте сами да ремонтирате сауната без разрешението на търговеца на сауна или производителя.

Опитите за неоторизиран ремонт ще анулират гаранцията на производителя.

Не използвайте почистващи продукти в сауната.







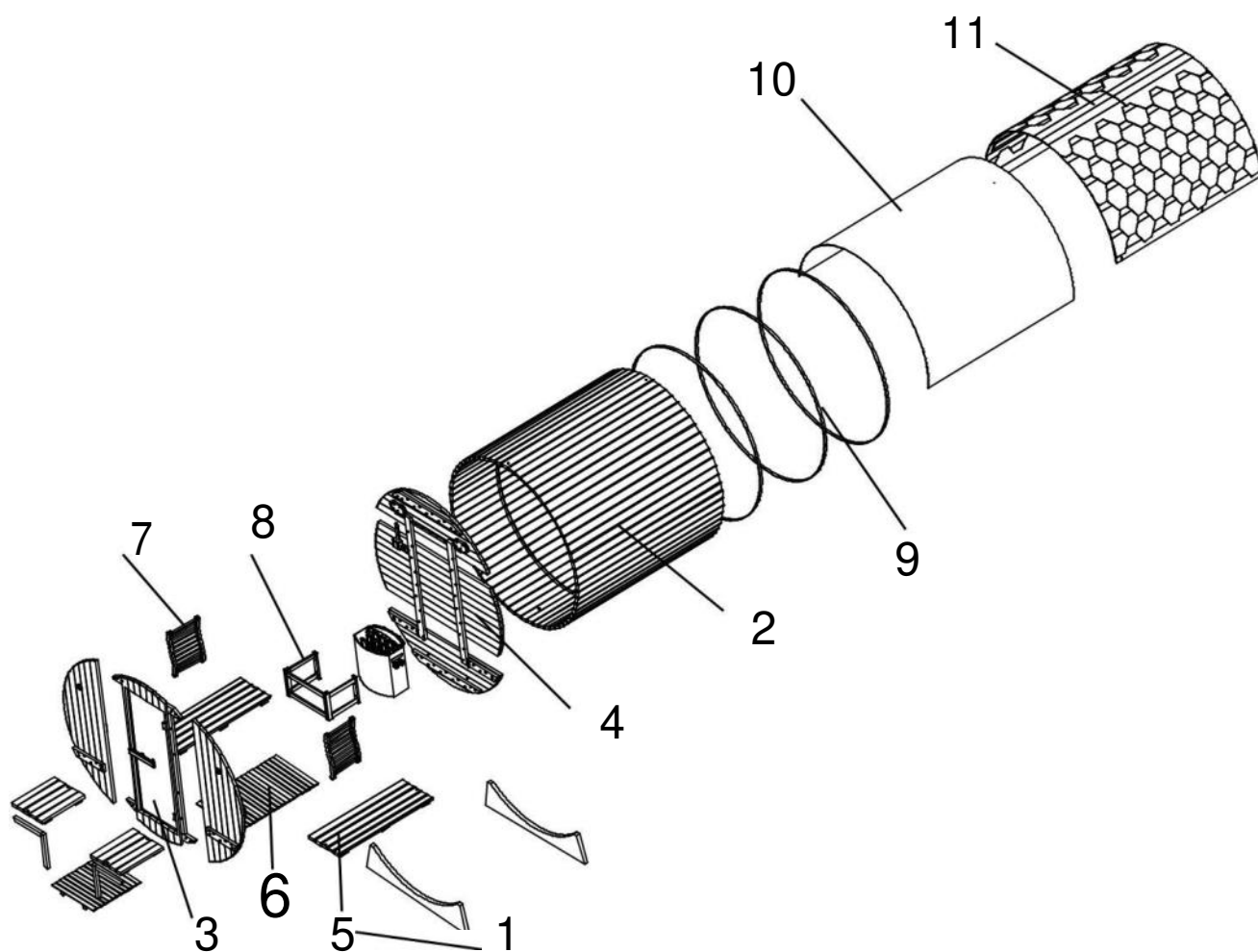



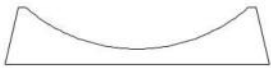

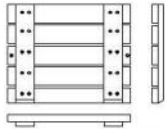
Не натрупвайте и не съхранявайте никакви предмети във или върху сауната.

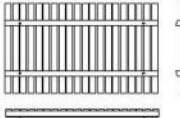
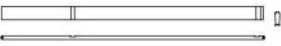
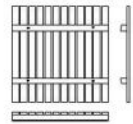
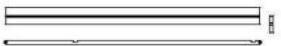
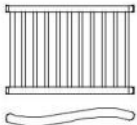
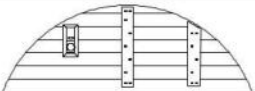
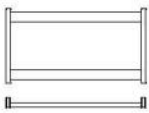
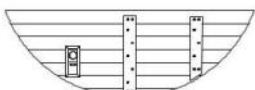
Не поставяйте запалими материали или химически вещества близо до сауната.

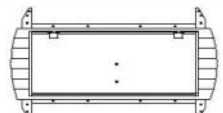

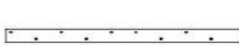
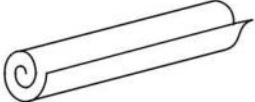

Описание

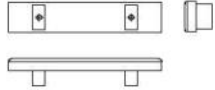
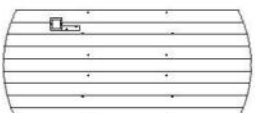
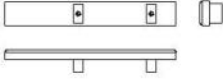
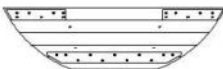
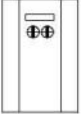
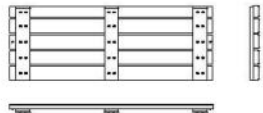
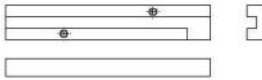



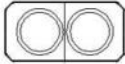
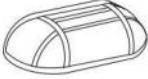

Описание на части

1		(1400x300x33mm) 2x	5.2		(426x398x30mm) 2x
2.1		(1800x93x30mm) 2x	5.3		(532x425x50mm) 2x
2.2		(1800x93x30mm) 1x	6.1		(990x585x40mm) 1x
2.3		(1800x93x30mm) 60x	6.2		(535x585x40mm) 1x
2.4		(1800x93x30mm) 1x	7		(520x330x65mm) 2x
3.1		(1758x575x30mm) 1x	8.1		(560x300x40mm) 1x
3.2		(1650x575x30mm) 1x	8.2		(378x300x40mm) 2x
3.3		(1758x952x30mm) 1x	9		3x Обръча
4.1		(1404x80x20mm) 1x	10		(3000x1800mm) 1x
4.2		(1404x80x20mm) 1x	11		(1000x320mm) 60x
4.3		(1574x488x30mm) 1x	12		(250x50x45mm) 1x
4.4		(1758x783x30mm) 1x	13		(350x50x45mm) 1x
4.5		(1574x488x30mm) 1x	14		1x Арперат
5.1		(1152x425x50mm) 2x	15		(177x80x30mm) 1x

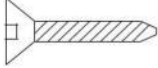
Описание на част

16		1x Тавичка за вода	20		1x Хигрометър
17		2x Плафон за крышка			1x Пясъчен часовник
18		2x Държач за чаша	22		1x Дърена лъжича
19		1x Кофа			

							
Ø5x50	Ø4x50	Ø4x30	Ø3x35	Ø4x12	Ø6x70		
44x	20x	8x	66x	240x	2x	2x	

Прочетете внимателно инструкциите за монтаж, преди да намерите подходящо място за вашата сауна.

Сауната е предназначена само за външен монтаж.

Избор на място:

- В сухо място, върху равна, стабилна повърхност, която може да издържи тежестта на сауната.
- Височината трябва да е такава, че да можете да достигнете тавана и да извършите електрическите връзки и работи по поддръжката.
- Далеч от източници на вода, пламъци или запалими материали..

Практически съвети

- Обърнете внимание, че са необходими най-малко 3ма възрастни за сглобяване на сауната.
- Внимателни огледайте всеки панел преди да започнете
- При монтаж, поставете захранващия кабел на вашата сауна така, че да е лесно достъпен.
- Имайте предвид, че има разлики между отделните модели.

ВАЖНО!

Моля, проверете зенкера и диаметъра на отворите, за да избегнете повреда на дървото.

Необходими инструменти



Отвертка



Ролетка



Молив



Ножче



2 гаечни ключа



Винтоверт



Бургия



Шестограм



Стълба



Чук

Асемблиране

Ø 5 x 50 20PCS

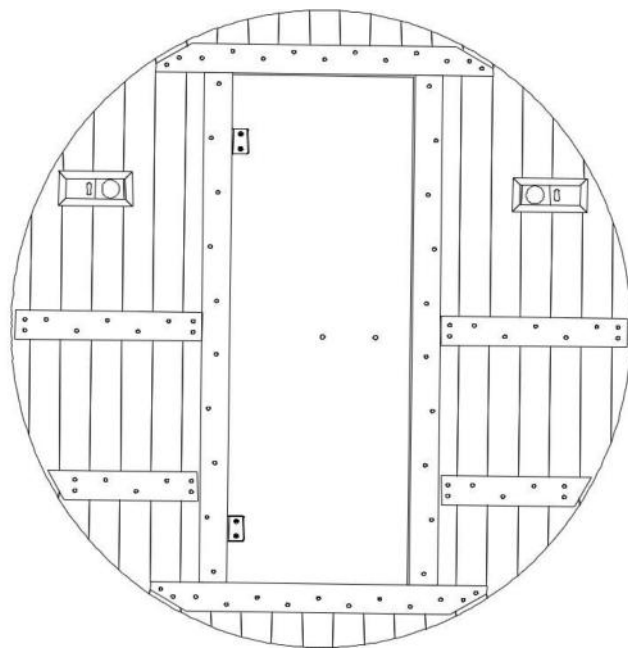
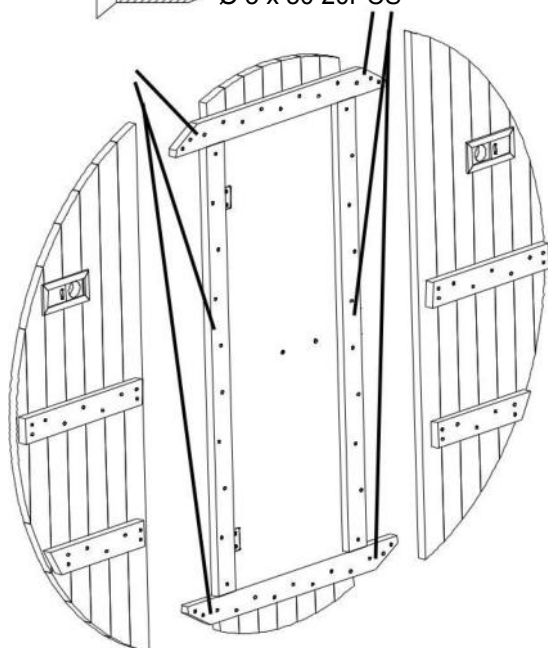

Ø 3 x 35 2PCS

Ø 5 x 50 18PCS

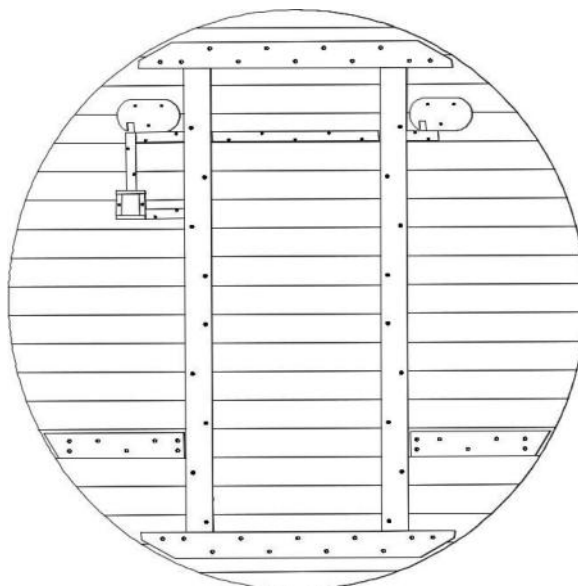
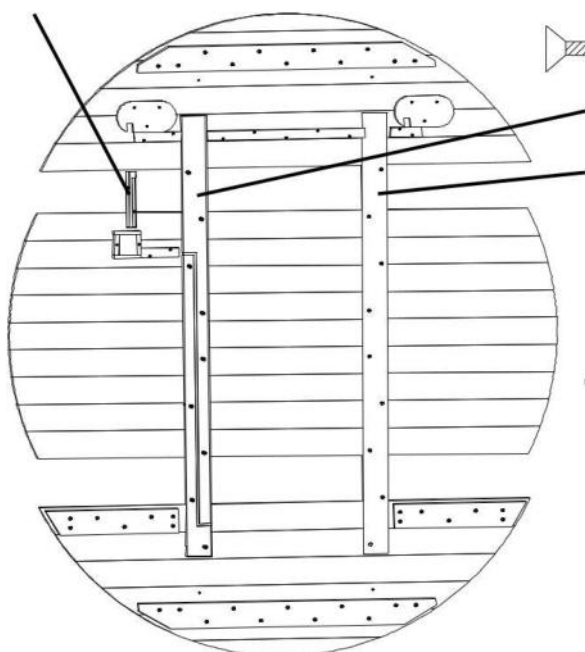

Първо трябва да сглобите предния и задния панел.

Предния панел е разделен на 3 части от ляво и дясно, задния панел е разделен на 3 части от горе и отдолу.

Асемблиране

Ø 5 x 50 2PCS

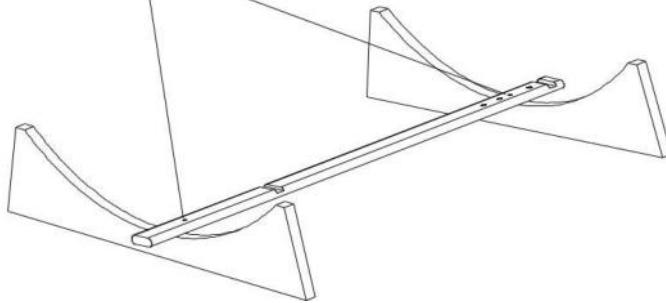

Basis

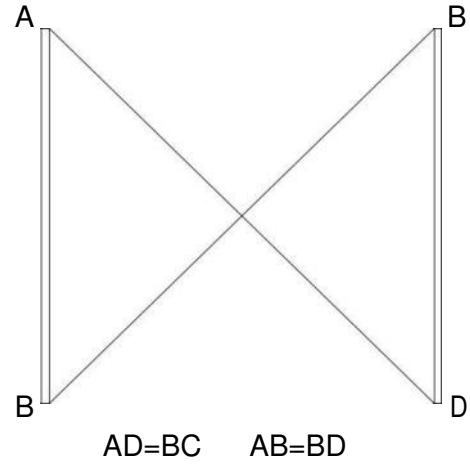

Всяка летва е номерирана и етикетирана.

Лявата страна е L01 L02 L03.....L38 отдолу нагоре;

Дясната страна е R01 R02 R03..... R38 отдолу нагоре.

Асемблиране

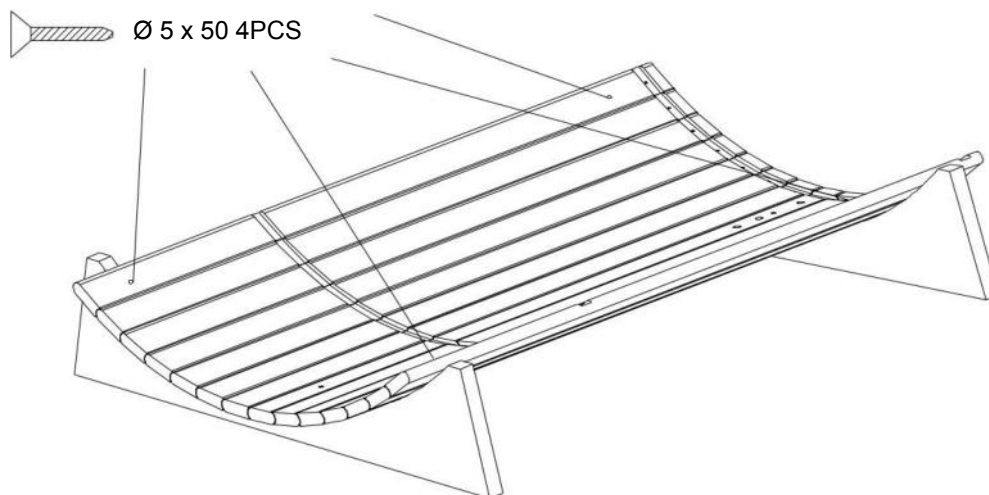

Долни ламели

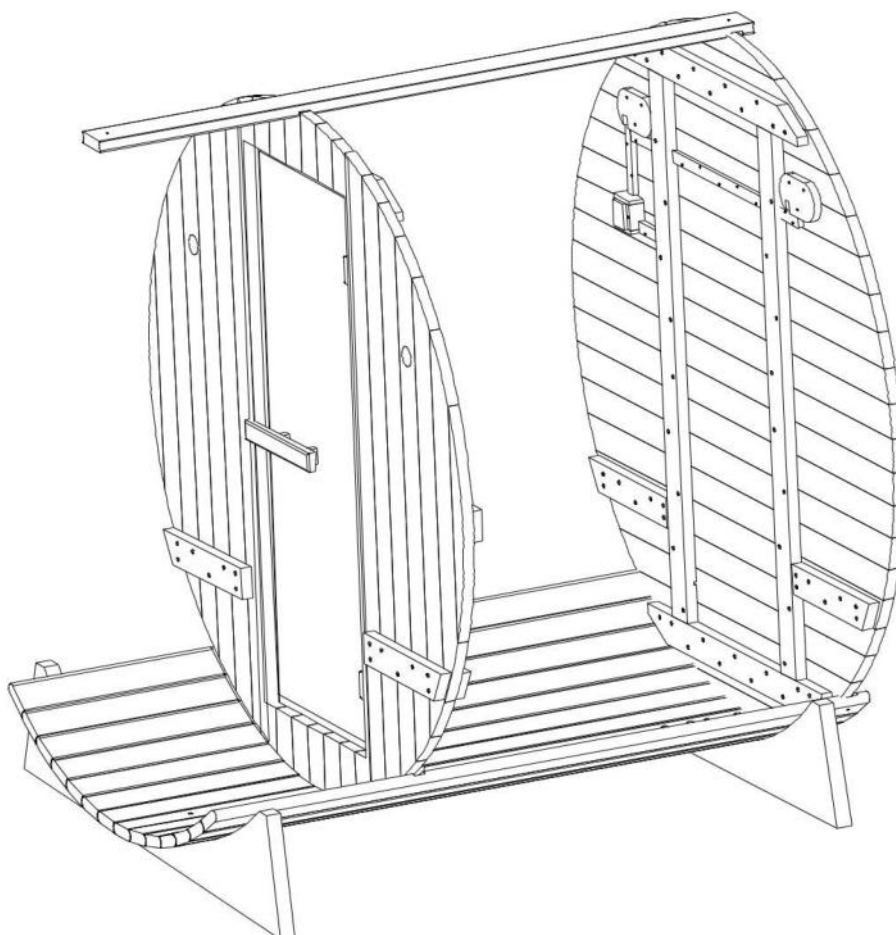

Горната греда се монтира временно като защитна мярка по време на монтажа !

Асемблиране

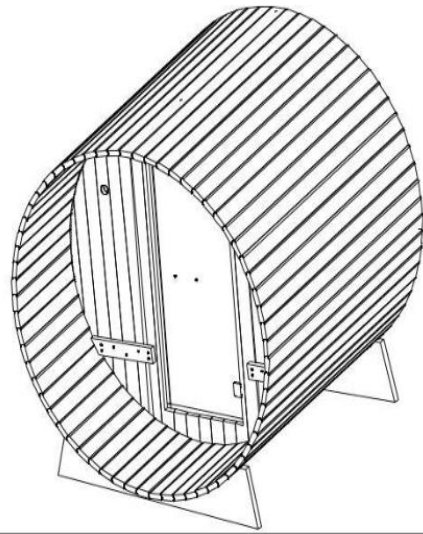
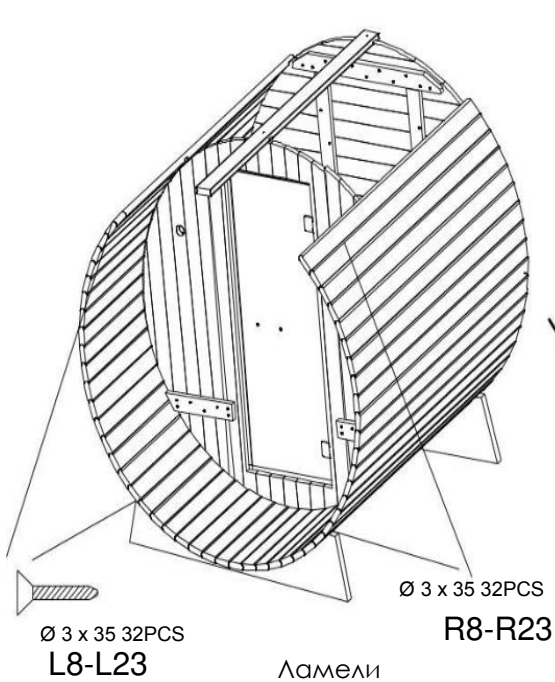

1. Ламелите на корпуса трябва да бъдат поставени плътно при монтаж, което благоприятства горната инсталация и плътност.
2. Винтове (M3*35 64PCS) се използват за фиксиране на ламелите L8-L23 и R8-R23, горните ламели се поставят плътно, след образуване на кръг, цевта е фиксирана с ленти от неръждаема стомана.

Според действителните изисквания за инсталиране, една или две тънки пластини в средата могат да се отстранят след разхлабване на винтовете.

ТЪНКИ ПЛОЧИ

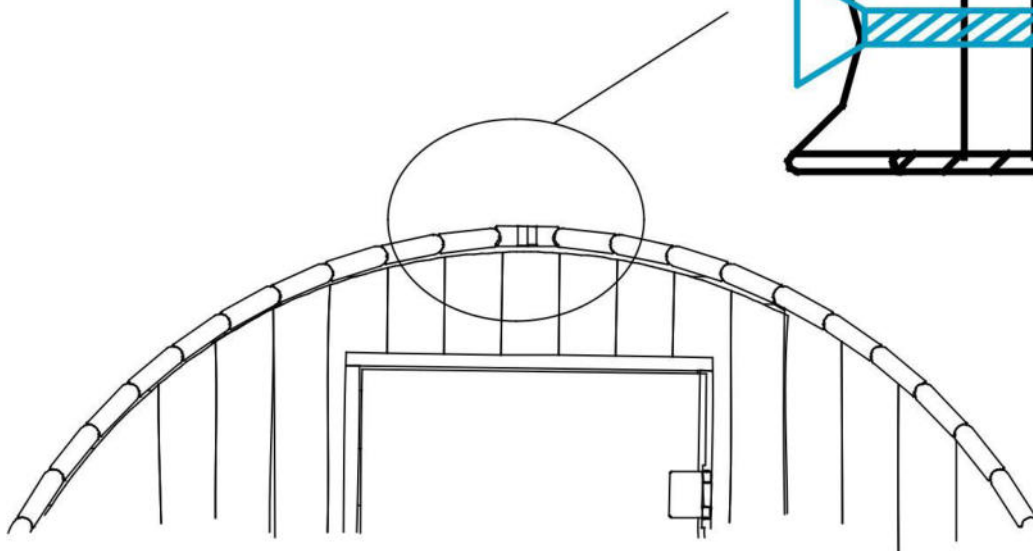
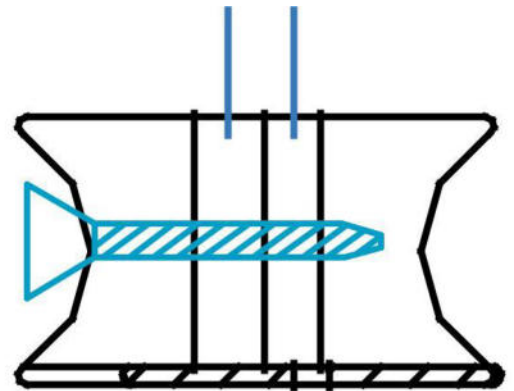

Асемблиране

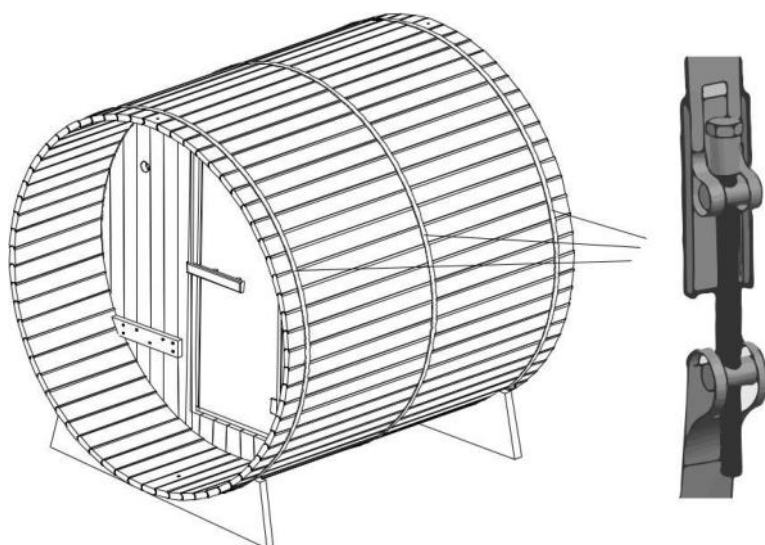

Ленти от неръждаема стомана

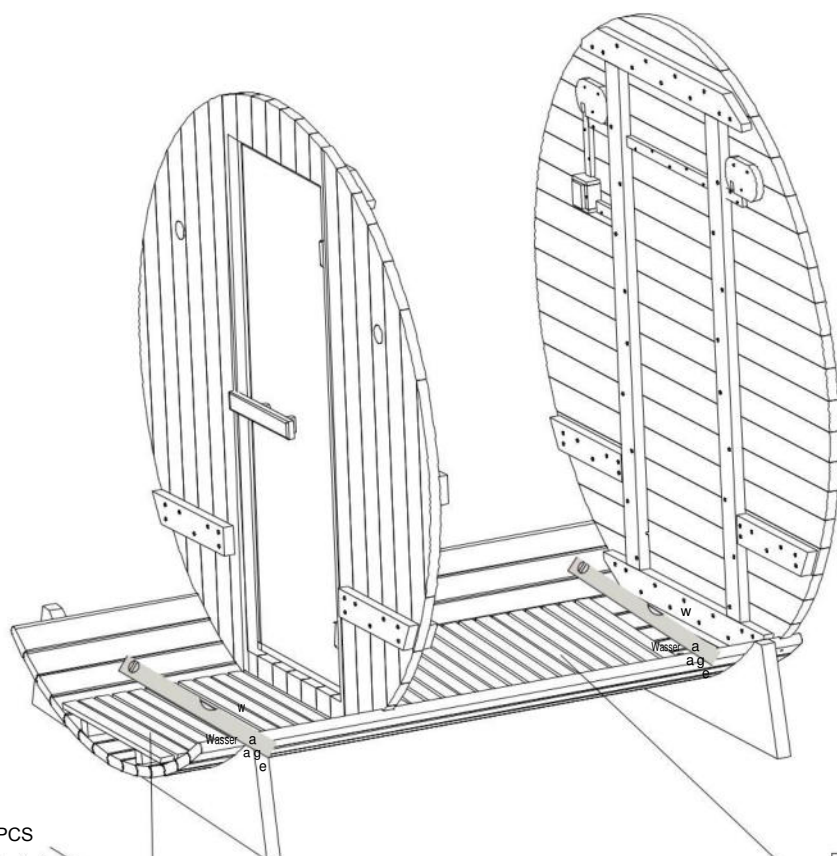

Ø 4 x 50 4PCS

Ø 4 x 50 4PCS

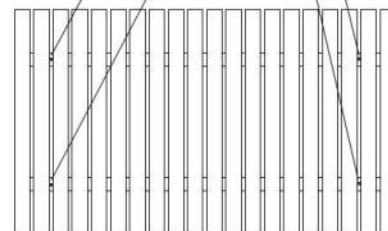
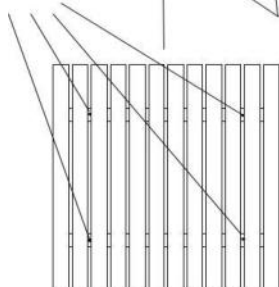

Поставка за крака

Асемблиране

Скобата за вътрешната и външната седалка е предварително монтирана. Външната основна плоча се нуждае от друга опорна рамка, а опорната рамка фиксира винтовете към ламелите. Вътрешната основна плоча не изисква допълнителна опорна рамка. Заклучващите винтове на плочата на седалката трябва да бъдат прикрепени към опорната страна на предната и задната плочи.

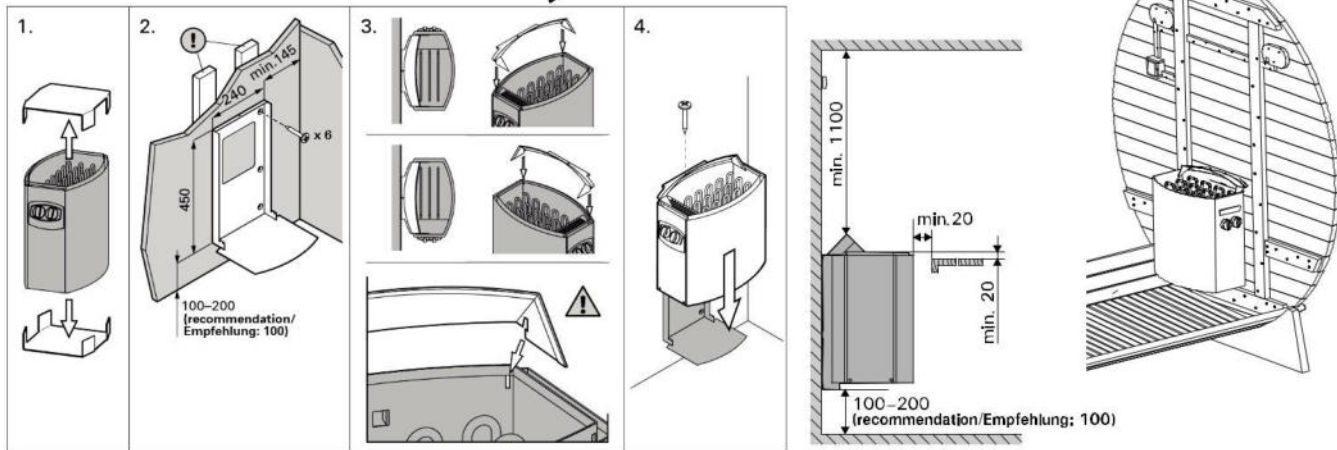
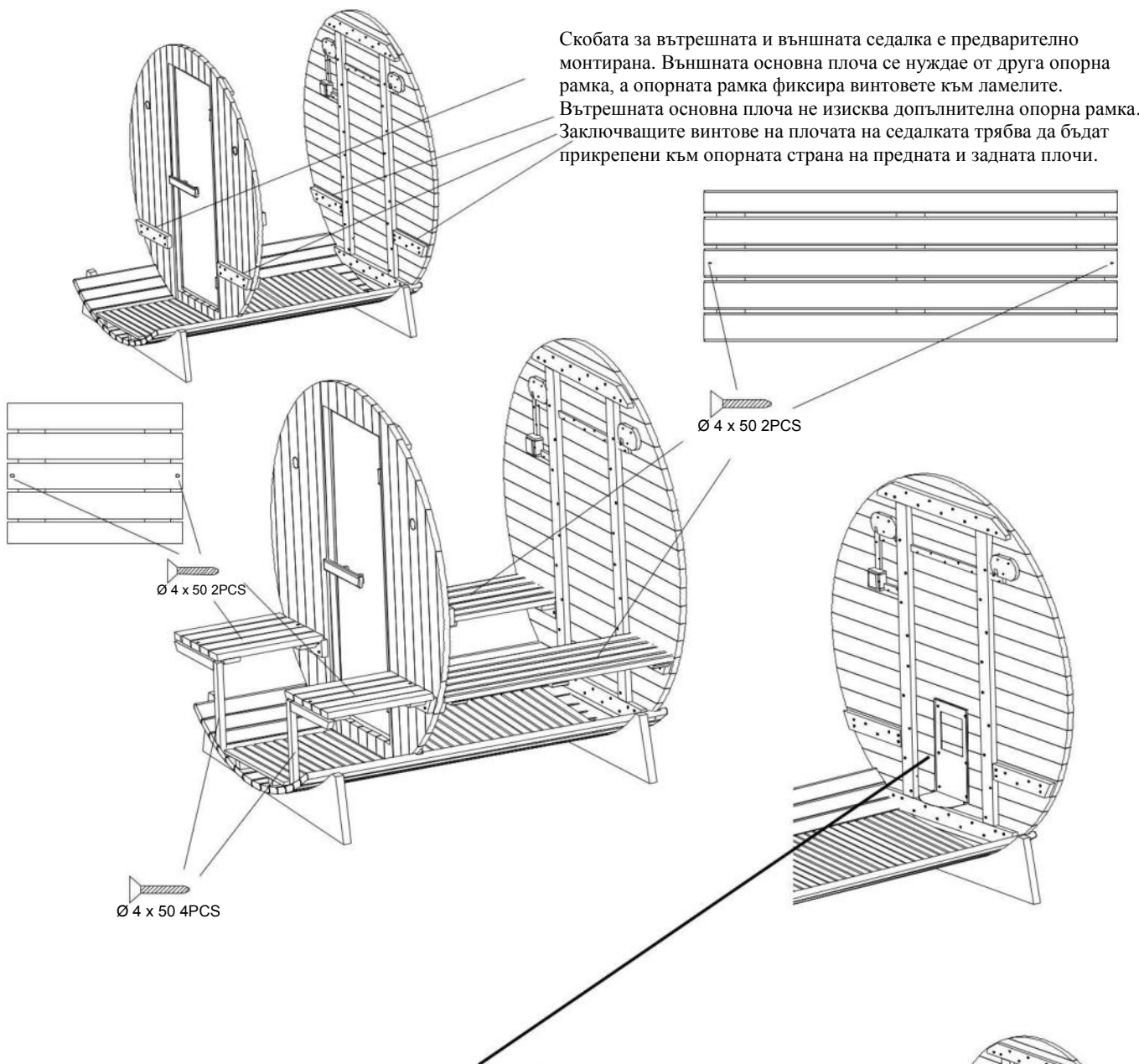

При инсталиране на сауна първо трябва да се монтира стенната скоба на рамката, на агрегата и след това да се окачи агрегата. Моля, вижте диаграмата за по-добра информация. За подробна информация вижте ръководството за агрегата.

Проводниците на лампата трябва да бъдат свързани към гнездото на кабела, на нагревателя и да се захранват от агрегата.

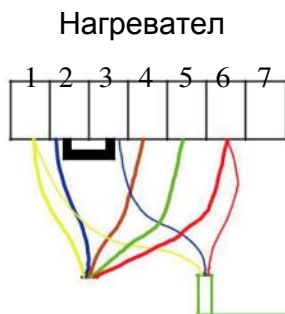
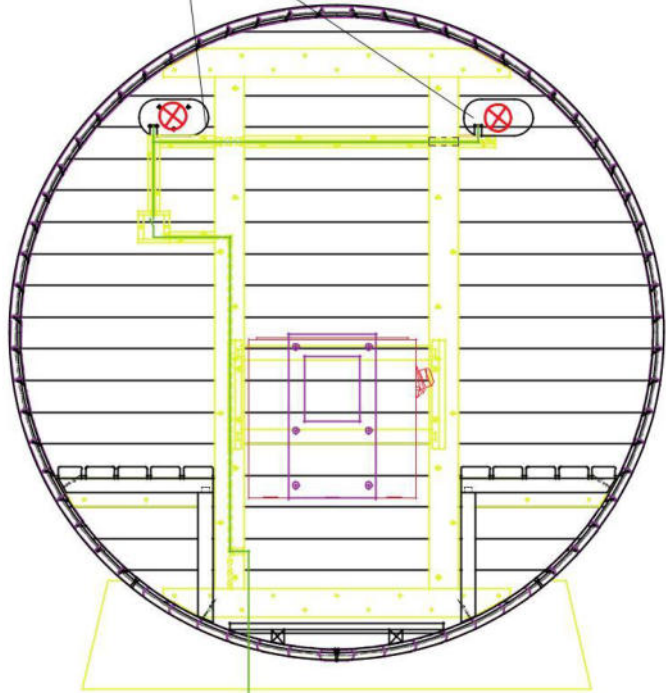
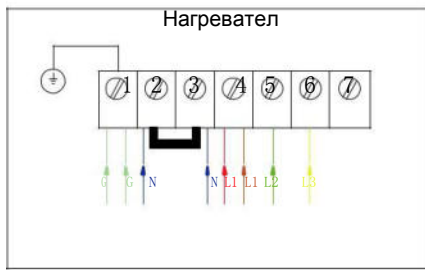
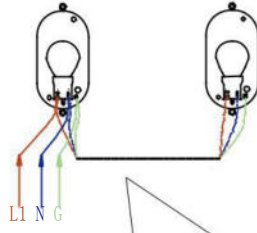

Лампова линия (3*0,75mm²)

Кабел (5*2,5mm²)

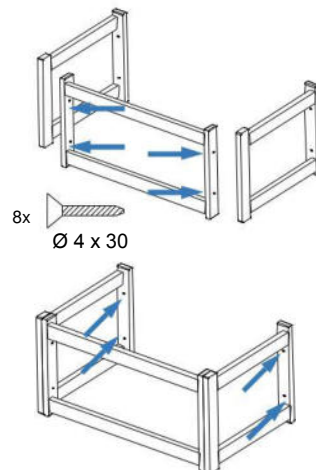
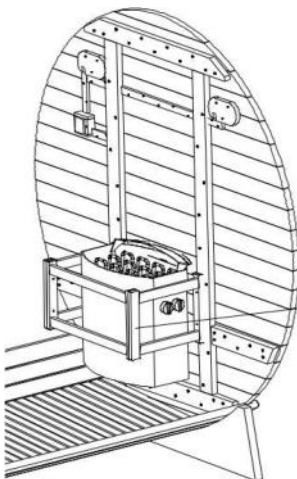

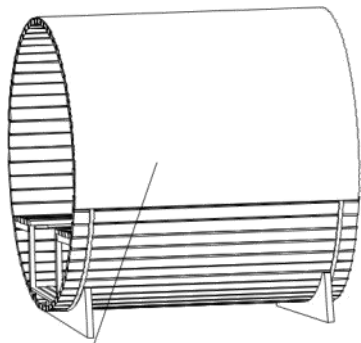

Водоустойчива материя

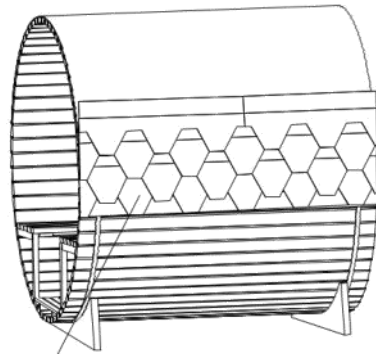

Асвалтова плоча

Ø 4 x 12 200PCS

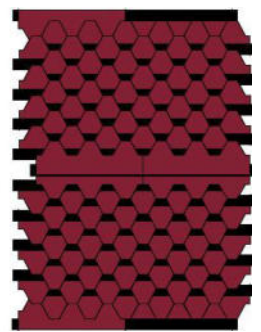
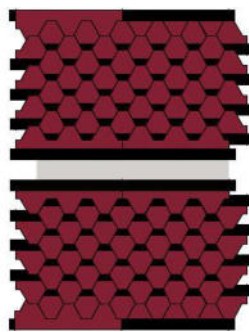
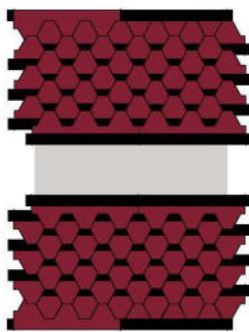
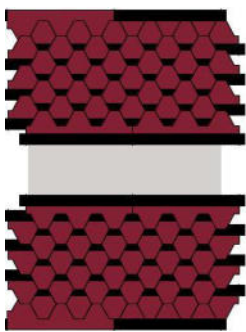
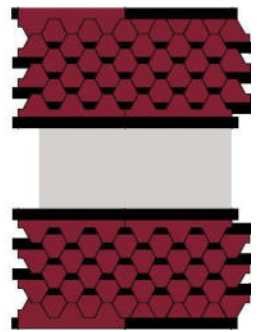
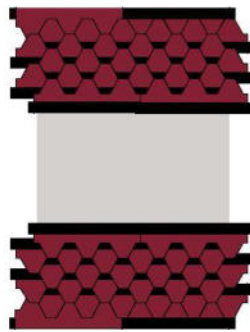
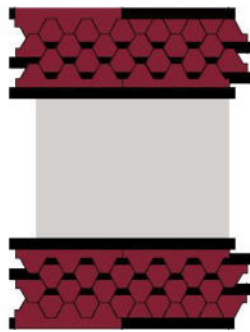
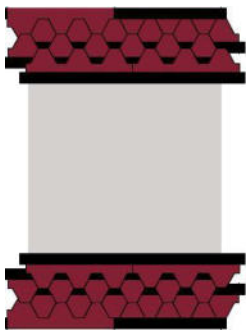
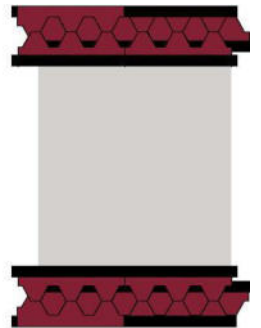
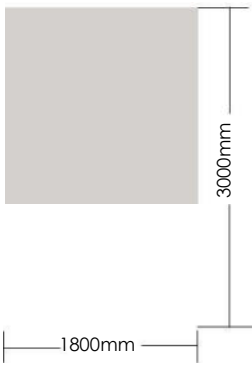

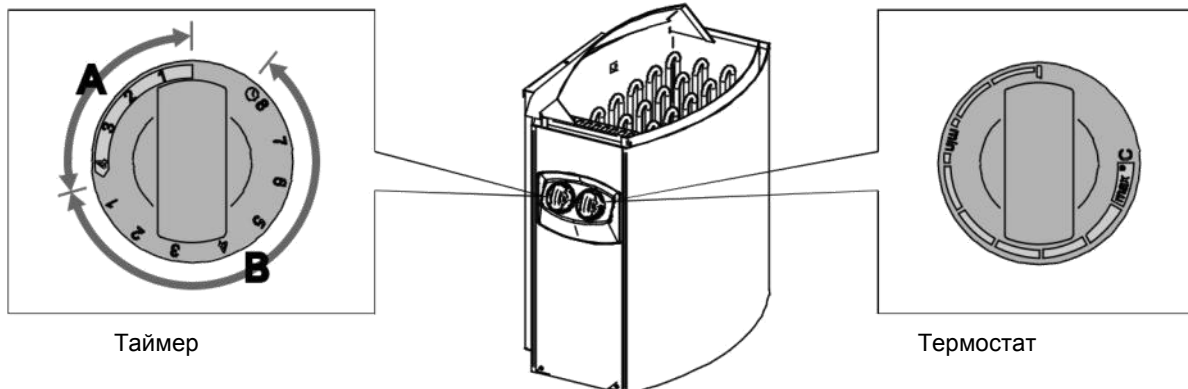

Таймер

Термостат

1. Включено



Превключете превключвателя на таймера на "включено".

(Секция А на фигура 2, 0-4 часа).

Нагревателят започва да загрева веднага.

2. Предварително зададено време за включване



Задайте превключвателя на таймера на раздела "Предварително зададени" (секция В на фигура 2, 0-8 часа). Нагревателят ще започне да загрева, когато таймерът върне превключвателя на "включено". След това нагревателят ще работи около четири часа.

За подробна информация разгледайте ръководството на агрегата за сауна !

Поддръжка

Защита на дървото

Почистете всяка външна летва и нанесете материал за защита на дърво, за да защитите дървото, след като монтажът приключи.

Защитният агент трябва да бъде подновяван според препоръките на използвания продукт

ВАЖНО!

Изключете захранващия кабел на кабината, преди да извършвате каквато и да е работа.

Евентуални проблеми	Възможни причини	Решение
Агрегатът не нагрява	Захранващия кабел не е свързан правилно.	Проверете захранващия кабел
	Общото захранване е прекъснато.	Проверете дали таблото и контакта работят
	Включила се е защитата от прегряване	Проверете в ръководството.
Осветлението не работи	Кабела за осветление не е свързан правилно.	Включете кабела.
	Крушката не работи.	Консултирайте се с вашия доставчик.

Съвети:

1. Изключете сауната си.
2. Използвайте прахосмукачка, за да отстраните праха от фугите в дървената ламперия.
3. Почистете кабината с влажна памучна кърпа, като използвате малко количество сапун, ако е необходимо. Изплакнете с влажна кърпа.
4. Почистете стъклото с препарат за почистване на прозорци/стъкла и мека кърпа.
5. Поддържайте външността на сауната с подходящ продукт на всеки 2 години.

Важно !

Дървото трябва да се третира само с консервант от външната страна на сауната.

В сауната не могат да се извършват процедури. Не използвайте бензол, алкохол, химически агенти или силни почистващи препарати върху сауната, тъй като химическите продукти могат да повредят дървото.

Не пръскайте сауната си с вода.

Моля, прочетете инструкциите, предоставени с печката за сауна, за монтаж и употреба на агрегата.

Нагревателят може да бъде свързан към захранването само от оторизиран електротехник в съответствие с приложимите разпоредби.

AT

Dieses Produkt enthält <2> Lichtquellen der Energieeffizienzklasse <G>

E

This product contains <2> light sources of energy efficiency class <G>

BG

Този продукт съдържа <2> светлинни източника с клас на енергийна ефективност <G>

HU

A termék <2> db <G> energiaosztályú fényforrást tartalmaz.

RO

Acest produs conține <2> surse de lumină din clasa de eficiență energetică <G>

SK

Tento produkt obsahuje <2> svetelné zdroje energetickej triedy <G>

CZ

Tento produkt obsahuje <2> světelné zdroje energetické třídy <G>

SI

Ta izdelek vsebuje <2> svetlobne vire energijske učinkovitosti razreda <G>

HR

Ovaj proizvod sadrži <2> izvor svjetlosti energetske učinkovitosti klase <G>

BC45, BC60, BC80, BC90 BC45E, BC60E, BC80E, BC90E

EN Instructions for Installation and Use of Electric Sauna Heater

BG Инструкции за инсталиране и използване на електрическа
печка за сауна



BC



BC-E

These instructions for installation and use are intended for the owner or the person in charge of the sauna, as well as for the electrician in charge of the electrical installation of the heater. After completing the installation, the person in charge of the installation should give these instructions to the owner of the sauna or to the person in charge of its operation. Please read the instructions for use carefully before using the heater.

The heater is designed for the heating of a sauna room to bathing temperature. It is not to be used for any other purpose.

Congratulations on your choice!

Guarantee:

- The guarantee period for heaters and control equipment used in saunas by families is two (2) years.
- The guarantee period for heaters and control equipment used in saunas by building residents is one (1) year.
- The guarantee does not cover any faults resulting from failure to comply with installation, use or maintenance instructions.
- The guarantee does not cover any faults resulting from the use of stones not recommended by the heater manufacturer.

CONTENTS

1. INSTRUCTIONS FOR USE	3
1.1. Piling of the Sauna Stones.....	3
1.1.1. Maintenance.....	3
1.2. Heating of the Sauna.....	4
1.3. Using the Heater.....	4
1.3.1. Heater On.....	4
1.3.2. Pre-setting Time (timed switch-on).....	4
1.3.3. Heater Off.....	5
1.3.4. Setting the Temperature.....	5
1.4. Throwing Water on Heated Stones.....	5
1.5. Instructions for Bathing.....	6
1.6. Warnings.....	6
1.7. Troubleshooting.....	6
2. SAUNA ROOM	8
2.1. Sauna Room Structure.....	8
2.1.1. Blackening of the sauna walls.....	8
2.2. Sauna Room Ventilation.....	9
2.3. Heater Output.....	9
2.4. Sauna Room Hygiene.....	9
3. INSTRUCTIONS FOR INSTALLATION	10
3.1. Before Installation.....	10
3.2. Fastening the Heater on a Wall.....	11
3.3. Electrical Connections.....	12
3.3.1. Electric Heater Insulation Resistance.....	12
3.4. Installation of the Control Unit and Sensors (BC-E).....	13
3.5. Resetting the Overheat Protector.....	13
4. SPARE PARTS	15

Тези инструкции за монтаж и експлоатация са предназначени за собственика на сауната или лицето, отговорно за поддръжката на сауната, както и за електротехника, отговорен за инсталирането на печката за сауна. Когато печката за сауна е сглобена, тези инструкции за монтаж и експлоатация се предоставят на собственика на сауната или на лицето, отговорно за поддръжката на сауната. Прочетете внимателно инструкциите за експлоатация, преди да използвате фурната.

Печката се използва за загряване на сауната до определена температура. Използването за други цели е забранено.

Поздравяваме Ви за добрия избор!

Гаранция:

- Гаранционният срок за нагревателите и контролерите за сауна, използвани за битови цели, е две (2) години.
- Гаранционният срок за нагревателите и контролерите за сауна, използвани в обществени сауни в частни сгради, е един (1) година.
- Гаранцията не покрива дефекти, причинени от неправилен монтаж и употреба или неспазване на инструкциите за поддръжка.
- Гаранцията не покрива повреди, причинени от използване на камъни, различни от препоръчаните от фабриката.

СЪДЪРЖАНИЕ

1. ИНСТРУКЦИИ ЗА УПОТРЕБА	3
1.1. Натрупване на камъни за сауна.....	3
1.1.1. Поддръжка.....	3
1.2. Затопляне на сауната.....	4
1.3. Използване на нагревателя.....	4
1.3.1. Включен нагревател.....	4
1.3.2. Време за предварителна настройка (включване по време).....	4
1.3.3. Изключен нагревател.....	5
1.3.4. Настройване на температурата.....	5
1.4. Хвърляне на вода върху нагорещени камъни.....	5
1.5. Инструкции за къпане.....	6
1.6. Предупреждения.....	6
1.7. Отстраняване на неизправности.....	6
2. САУНА	8
2.1. Структура на помещението за сауна.....	8
2.1.1. Почерняване на стените на сауната.....	8
2.2. Вентилация на сауната.....	9
2.3. Мощност на нагревателя.....	9
2.4. Хигиена на помещението за сауна.....	9
3. ИНСТРУКЦИИ ЗА ИНСТАЛИРАНЕ	10
3.1. Преди инсталиране.....	10
3.2. Закрепване на нагревателя към стена.....	11
3.3. Електрически връзки.....	12
3.3.1. Съпротивление на изолацията на електрическия нагревател.....	12
3.4. Монтаж на управляващия блок и сензори (BC-E).....	13
3.5. Нулиране на защитата от прегряване.....	13
4. РЕЗЕРВНИ ЧАСТИ	15

1. INSTRUCTIONS FOR USE

1.1. Piling of the Sauna Stones

The piling of the sauna stones has a great effect on the functioning of the heater (figure 1).

Important information on sauna stones:

- The stones should be 5–10 cm in diameter.
- Use solely angular split-face sauna stones that are intended for use in a heater. Peridotite, olivine-dolerite and olivine are suitable stone types.
- **Neither light, porous ceramic “stones” nor soft soapstones should be used in the heater. They do not absorb enough heat when warmed up. This can result in damage in heating elements.**
- Wash off dust from the stones before piling them into the heater.

Please note when placing the stones:

- Do not drop stones into the heater.
- Do not wedge stones between the heating elements.
- Place the stones sparsely to ensure that air can circulate between them.
- Pile the stones so that they support each other instead of lying their weight on the heating elements.
- Do not form a high pile of stones on top of the heater.
- No such objects or devices should be placed inside the heater stone space or near the heater that could change the amount or direction of the air flowing through the heater.

1. РЪКОВОДСТВО ЗА ЕКСПЛОАТАЦИЯ

1.1. Поддръждане на камъни за печка за сауна

Натрупването на камъни за сауна оказва голямо влияние върху функционирането на печката (фигура 1).

Важна информация за камъните за сауна:

- Камъните трябва да са с диаметър 5–10 см.
- Използвайте само ъглови камъни за сауна с разделено лице, които са предназначени за използване в печка. Перидотит, оливин-долерит и оливин са подходящи видове камъни.
- В нагревателя не трябва да се използват нито леки, порести керамични „камъчета“, нито меки сапунени камъни. Те не абсорбират достатъчно топлина при загряване. Това може да доведе до повреда в нагревателните елементи.
- Измийте праха от камъните, преди да ги натрупате в печката..

Моля, имайте предвид, когато поставяте камъните:

- Не пускайте камъни в печката.
- Не поставяйте камъни между нагревателните елементи
- Поставете камъните на рядко, за да осигурите циркулация на въздуха между тях.
- Натрупвайте камъните така, че да се поддържат един друг, вместо да лежат с тежестта си върху нагревателните елементи.
- Не образувайте висока купчина камъни върху печката.
- Не трябва да се поставят такива предмети или устройства в пространството на нагревателя или близо до нагревателя, които могат да променят количеството или посоката на въздуха, протичащ през нагревателя.

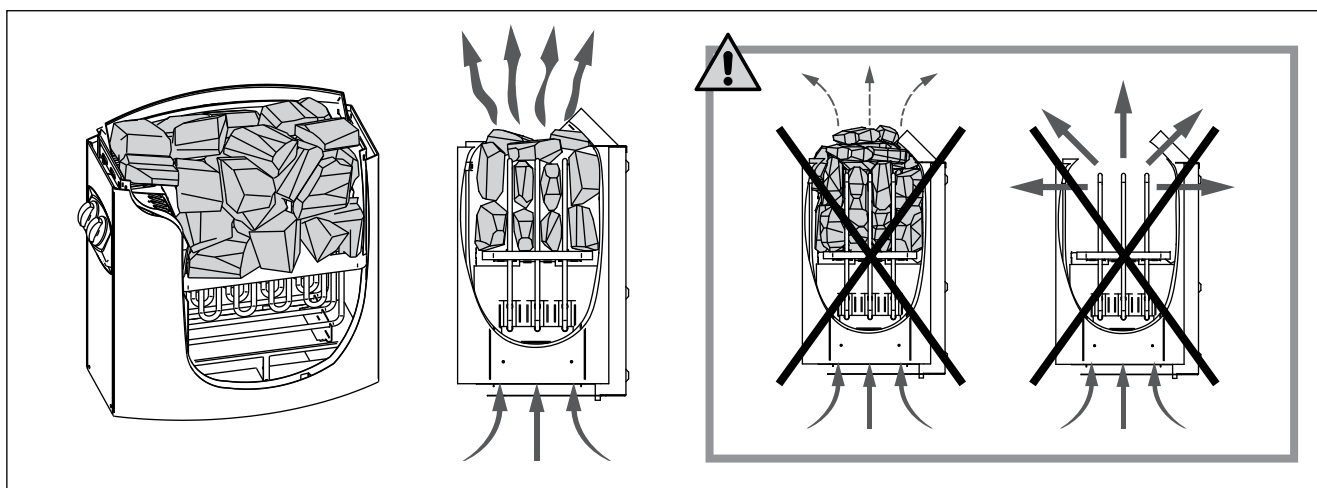

Figure 1. Piling of the sauna stones
Фигура 1. Натрупване на камъни за сауна

1.1.1. Maintenance

Due to large variation in temperature, the sauna stones disintegrate in use. Rearrange the stones at least once a year or even more often if the sauna is in frequent use. At the same time, remove any pieces of stones from the bottom of the heater and replace any disintegrated stones with new ones. By doing this, the heating capability of the heater stays optimal and the risk of overheating is avoided.

1.1.1. Поддръжка

Поради големи колебания в температурата, камъните за сауна се разпадат при употреба. Пренареждайте камъните поне веднъж годишно или дори по-често, ако сауната се използва често. В същото време отстранете всички парчета камъни от дъното на нагревателя и сменете всички разпаднали се камъни с нови. По този начин отоплителният капацитет на нагревателя остава оптимален и рискът от прегряване се избягва.

1.2. Heating of the Sauna

When operating the heater for the first time, both the heater and the stones emit smell. To remove the smell, the sauna room needs to be efficiently ventilated.

If the heater output is suitable for the sauna room, it will take about an hour for a properly insulated sauna to reach the required bathing temperature (▷ 2.3.). The sauna stones normally reach the bathing temperature at the same time as the sauna room. A suitable temperature for the sauna room is about 65–80 °C.

1.3. Using the Heater

Before switching the heater on always check that there isn't anything on top of the heater or inside the given safety distance. ▷ 1.6.

- Heater models BC45, BC60, BC80 and BC90 are equipped with a timer and a thermostat. The timer is for setting the on-time for the heater and the thermostat is for setting a suitable temperature. ▷ 1.3.1.–1.3.4.
- Heater models BC45E, BC60E, BC80E and BC90E are controlled from a separate control unit. See the instructions for use of the selected control unit model.

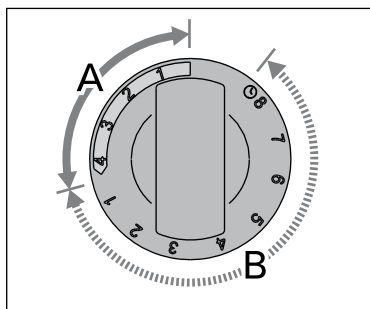

Figure 2. Timer switch
Фигура 2. Превключвател с таймер

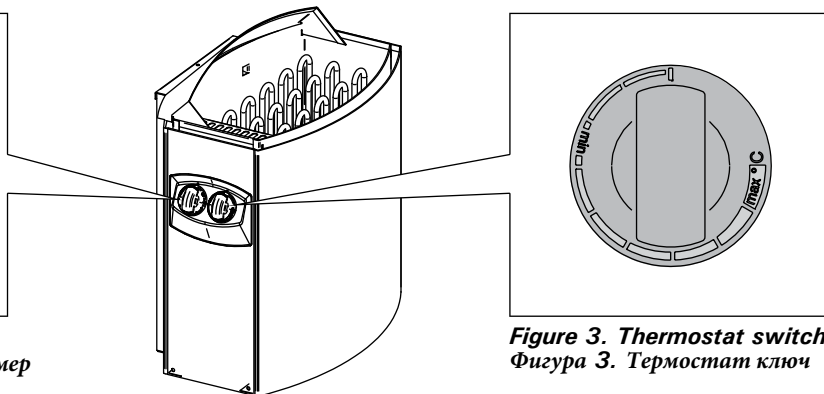
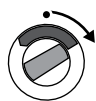

Figure 3. Thermostat switch
Фигура 3. Термостат ключ

1.3.1. Heater On



Turn the timer switch to the "on" section (section A in figure 2, 0–4 hours). The heater starts heating immediately.

1.3.2. Pre-setting Time (timed switch-on)



Turn the timer switch to the "pre-setting" section (section B in figure 2, 0–8 hours). The heater starts heating when the timer has turned the switch back to the "on" section. After this, the heater will be on for about four hours.

Example: You want to go walking for three hours and have a sauna bath after that. Turn the timer switch to the "pre-setting" section at number 2.

The timer starts. After two hours, the heater starts heating. Because it takes about one hour for the sauna to be heated, it will be ready for bathing after about three hours, that is, when you come back from your walk.

1.2. Отопление на сауната

Когато включите нагревателя за първи път, както нагревателят, така и камъните излъчват миризма. За да премахнете миризмата, помещението на сауната трябва да бъде добре вентилирано.

Ако мощността на нагревателя е подходяща за стаята със сауна, ще отнеме около час, за да достигне необходимата температура за къпане на добре изолирана сауна (2.3.). Камъните за сауна обикновено достигат температурата за къпане едновременно със сауната. Подходящата температура за сауната е около 65–80 °C.

1.3. Използване на нагревателя

Преди да включите нагревателя, винаги проверявайте дали няма нищо отгоре на нагревателя или в рамките на даденото безопасно разстояние. 1.6.

- Нагревателите модели BC45, BC60, BC80 и BC90 са оборудвани с таймер и термостат. Таймерът е за настройка на времето за включване на нагревателя, а термостатът е за задаване на подходяща температура. 1.3.1.–1.3.4.
- Нагревателите модели BC45E, BC60E, BC80E и BC90E се управляват от отделен блок за управление. Вижте инструкциите за употреба на избрания модел контролен блок.

1.3.1. Включване на нагревател

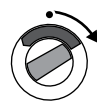

Завъртете превключвателя на таймера в положение „включено“ (секция А на фигура 2, 0–4 часа). Нагревателят започва да загрява веднага.

1.3.2. Предварителна настройка на времето (включване на таймера)



Завъртете превключвателя на таймера в раздел „предварителна настройка“ (секция В на фигура 2, 0–8 часа). Нагревателят започва да загрява, когато таймерът върне превключвателя обратно на „включено“

След това нагревателят ще работи около четири часа.

Пример: Искате да се разходжате три часа и след това да вземете сауна. Завъртете превключвателя на таймера в секцията "предварителна настройка" на номер 2.

Таймерът стартира. След два часа нагревателят започва да загрява. Тъй като загряването на сауната отнема около един час, тя ще бъде готова за къпане след около три часа, тоест когато се върнете от разходката си.

1.3.3. Heater Off



The heater switches off, when the timer turns the switch back to zero. You can switch the heater off at any time by turning the timer switch to zero yourself.

Switch the heater off after bathing. Sometimes it may be advisable to leave the heater on for a while to let the wooden parts of the sauna dry properly.

NOTE! Always check that the heater has switched off and stopped heating after the timer has turned the switch to zero.

1.3.4. Setting the Temperature

The purpose of the thermostat (figure 3) is to keep the temperature in the sauna room on a desired level. By experimenting, you can find the setting that suits you best.

Begin experimenting at the maximum position. If, during bathing, the temperature rises too high, turn the switch counter-clockwise a little. Note that even a small difference within the maximum section will change the temperature of the sauna considerably.

1.4. Throwing Water on Heated Stones

The air in the sauna room becomes dry when warmed up. Therefore, it is necessary to throw water on the heated stones to reach a suitable level of humidity in the sauna. The effect of heat and steam on people varies – by experimenting, you can find the levels of temperature and humidity that suit you best.

NOTE! The maximum volume of the ladle is 0.2 litres. If an excessive amount of water is poured on the stones, only part of it will evaporate and the rest may splash as boiling hot water on the bathers. Never throw water on the stones when there are people near the heater, because hot steam may burn their skin.

NOTE! The water to be thrown on the heated stones should meet the requirements of clean household water (table 1). Only special aromas designed for sauna water may be used. Follow the instructions given on the package.

1.3.3. Изключване на нагревателя



Нагревателят се изключва, когато таймерът върне ключа обратно на нула. Можете да изключите нагревателя по всяко време, като сами завъртите ключа на таймера на нула.

Изключете нагревателя след къпане. Понякога може да е препоръчително да оставите нагревателя включен за известно време, за да оставите дървените части на сауната да изсъхнат добре.

ЗАБЕЛЕЖКА! Винаги проверявайте дали нагревателят се е изключил и спрял да нагрява, след като таймерът е обърнал ключа на нула.

1.3.4. Настройка на температурата

Целта на термостата (фигура 3) е да поддържа температурата в сауната на желаното ниво. Като експериментирате, можете да намерите настройката, която ви подхожда най-добре.

Започнете да експериментирате от максималната позиция. Ако по време на къпане температурата се покачи твърде високо, завъртете леко ключа обратно на часовниковата стрелка. Имайте предвид, че дори малка разлика в максималната секция ще промени значително температурата на сауната

1.4. Хвърляне на вода върху нагорещени камъни

Въздухът в сауната става сух, когато се загрее. Затова е необходимо да се хвърля вода върху нагретите камъни, за да се достигне подходящо ниво на влажност в сауната. Ефектът на топлината и парата върху хората варира – като експериментирате, можете да намерите нивата на температура и влажност, които ви подхождат най-добре.

ЗАБЕЛЕЖКА! Максималният обем на черпака е 0,2 литра. Ако върху камъните се излее прекалено много вода, само част от нея ще се изпари, а останалата част може да пръсне като вряла вода върху къпещите се. Никога не хвърляйте вода върху камъните, когато в близост до печката има хора, защото горещата пара може да изгори кожата им.

ЗАБЕЛЕЖКА! Водата, която се налива върху нагорещените камъни трябва да отговаря на изискванията за чиста битова вода (таблица 1). Могат да се използват само специални аромати, предназначени за вода в сауна. Следвайте инструкциите на опаковката.

Water property Свойство на водата	Effect Ефект	Recommendation Препоръка
Humus concentration Концентрация на хумус	Colour, taste, precipitates Цвят, вкус, утайки	< 12 mg/l
Iron concentration Концентрация на желязо	Colour, odour, taste, precipitates Цвят, мирис, вкус, утайка	< 0,2 mg/l
Hardness: most important substances are manganese (Mn) and lime, i.e. calcium (Ca). Твърдост: най-важните вещества са манган (Mn) и вар, т.е. калций (Ca).	Precipitates Утаява	Mn: < 0,05 mg/l Ca: < 100 mg/l
Chlorinated water Хлорирана вода	Health risk Риск за здравето	Forbidden to use Забранено за използване
Seawater Морска вода	Rapid corrosion Бърза корозия	Forbidden to use Забранено за използване

Table 1. Water quality requirements
Таблица 1. Изисквания за качеството на водата

1.5. Instructions for Bathing

- Begin by washing yourself.
- Stay in the sauna for as long as you feel comfortable.
- Forget all your troubles and relax.
- According to established sauna conventions, you must not disturb other bathers by speaking in a loud voice.
- Do not force other bathers from the sauna by throwing excessive amounts of water on the stones.
- Cool your skin down as necessary. If you are in good health, you can have a swim if a swimming place or pool is available.
- Wash yourself after bathing.
- Rest for a while and let your pulse go back to normal. Have a drink of fresh water or a soft drink to bring your fluid balance back to normal.

1.6. Warnings

- **Staying in the hot sauna for long periods of time makes the body temperature rise, which may be dangerous.**
- **Keep away from the heater when it is hot. The stones and outer surface of the heater may burn your skin.**
- **Keep children away from the heater.**
- **Do not let young, handicapped or ill people bathe in the sauna on their own.**
- **Consult your doctor about any health-related limitations to bathing.**
- **Consult your child welfare clinic about taking little babies to the sauna.**
- **Be very careful when moving in the sauna, as the platform and floors may be slippery.**
- **Never go to a hot sauna if you have taken alcohol, strong medicines or narcotics.**
- **Never sleep in a hot sauna.**
- **Sea air and a humid climate may corrode the metal surfaces of the heater.**
- **Do not hang clothes to dry in the sauna, as this may cause a risk of fire. Excessive moisture content may also cause damage to the electrical equipment.**

1.7. Troubleshooting

Note! All service operations must be done by professional maintenance personnel.

The heater does not heat.

- Check that the fuses to the heater are in good condition.
- Check that the connection cable is connected (▷ 3.3.).
- Turn the timer switch to the "on" section (▷ 1.3.1.).
- Turn the thermostat to a higher setting (▷ 1.3.4.).
- Check that the overheat protector has not gone off. The timer works but the heater does not heat. (▷ 3.5.)

The sauna room heats slowly. The water thrown on the sauna stones cools down the stones quickly.

- Check that the fuses to the heater are in good

1.5. Инструкции за къпане

- Започнете, като се измиете.
- Останете в сауната толкова дълго, колкото се чувствате комфортно.
- Забравете всичките си проблеми и се отпуснете.
- Съгласно установените конвенции за сауната, не трябва да безпокоите другите къпеещи се, като говорите на висок глас.
- Не принуждавайте другите къпеещи се да напуснат сауната, като изхвърляте прекалено много вода върху камъните.
- Охладете кожата си, ако е необходимо. Ако сте в добро здраве, можете да плувате, ако има място за плуване или басейн.
- Измийте се след къпане.
- Починете си известно време и оставете пулса си да се нормализира. Изпийте прясна вода или безалкохолна напитка, за да върнете баланса на течностите си в норма.

1.6. Предупреждения

- **Продължителният престой в горещата сауна води до повишаване на телесната температура, което може да бъде опасно.**
- **Дръжте далече от нагревателя, когато е горещ. Камъните и външната повърхност на нагревателя могат да изгорят кожата ви.**
- **Дръжте децата далеч от печката.**
- **Не позволявайте на млади, инвалиди или болни хора да се къпят сами в сауната.**
- **Консултирайте се с вашия лекар за всякакви здравословни ограничения за къпане.**
- **Консултирайте се с вашата детска клиника относно воденето на малки бебета на сауна.**
- **Бъдете много внимателни, когато се движите в сауната, тъй като платформата и подовите може да са хлъзгави.**
- **Никога не ходете на гореща сауна, ако сте приемали алкохол, силни лекарства или наркотици.**
- **Никога не спете в гореща сауна.**
- **Морският въздух и влажният климат могат да корозират металните повърхности на нагревателя.**
- **Не окачвайте дрехи за сушене в сауната, тъй като това може да доведе до опасност от пожар. Прекомерното съдържание на влага може също да причини повреда на електрическото оборудване.**

1.7. Забележка за отстраняване на неизправности!

Всички сервизни операции трябва да се извършват от професионален персонал по поддръжката.

Нагревателят не загрява.

- Проверете дали предпазителите към нагревателя са в добро състояние.
- Проверете дали свързващият кабел е свързан (3.3.). ▷
- Завъртете превключвателя на таймера в положение "включено" ▷
- (1.3.1.).
- Завъртете термостата на по-висока настройка
- (1.3.4.).
- Проверете дали предпазителят от прегряване не се е задействал. Таймерът работи, но нагревателят не загрява. (3.5.)

Сауната се нагрява бавно. Водата, излята върху камъните за сауна, бързо охлажда камъните.

condition.

- Check that all heating elements glow when the heater is on.
- Turn the thermostat to a higher setting (▷ 1.3.4.).
- Check that the heater output is sufficient (▷ 2.3.).
- Check the sauna stones (▷ 1.1.). Too tightly piled stones, the settling of stones with time or wrong stone type can hinder the air flow through the heater, which results in reduced heating efficiency.
- Check that the sauna room ventilation has been arranged correctly (▷ 2.2.).

The sauna room heats quickly, but the temperature of the stones remain insufficient.

Water thrown on the stones runs through.

- Turn the thermostat to a lower setting (▷ 1.3.4.).
- Check that the heater output is not too high (▷ 2.3.).
- Check that the sauna room ventilation has been arranged correctly (▷ 2.2.).

The sauna room heats unevenly.

- Check that the heater has been installed in the correct height. The heater heats the sauna best, when it is installed 100 mm from the floor. The maximum installation height is 200 mm. (▷ 3.2.)

Panel or other material near the heater blackens quickly.

- Check that the requirements for safety distances are fulfilled (▷ 3.1.).
- Check the sauna stones (▷ 1.1.). Too tightly piled stones, the settling of stones with time or wrong stone type can hinder the air flow through the heater, which may result in overheating of surrounding materials.
- Also see section 2.1.1.

The heater emits smell.

- See section 1.2.
- The hot heater may emphasize odours mixed in the air that are not, however, caused by the sauna or the heater. Examples: paint, glue, oil, seasoning.

The heater makes noise.

- BC: The timer is a mechanical device and it makes a ticking sound when it is functioning normally. If the timer ticks even when the heater is switched off, check the timer's wiring.
- Occasional bangs are most likely caused by stones cracking due to heat.
- The thermal expansion of heater parts can cause noises when the heater warms up.

- Проверете дали предпазителите към нагревателя са в добро състояние
- Проверете дали всички нагревателни елементи светят, когато нагревателят е включен.
- Завъртете термостата на по-висока настройка (1.3.4.). ▷
- Проверете дали мощността на нагревателя е достатъчна ▷
- (2.3.). ▷
- Проверете камъните за сауната (1.1.). Твърде плътно натрупаните камъни, утаяването на камъните с времето или грешният вид камъни могат да възпрепятстват въздушния поток през нагревателя, което води до намалена ефективност на отоплението.
- Проверете дали вентилацията на сауната е ▷ подредена правилно (2.2.).

Сауната се затопля бързо, но температурата на камъните остава недостатъчна. Водата, хвърлена върху камъните, тече.

- Завъртете термостата на по-ниска настройка (1.3.4.). ▷
- Проверете дали мощността на нагревателя не е твърде висока (2.3.).
- Проверете дали вентилацията на сауната е ▷ подредена правилно (2.2.).

Сауната се нагрива неравномерно.

- Проверете дали нагревателят е монтиран в правилната височина. Печката загрява най-добре сауната, когато е монтирана на 100 мм от пода. Максималната монтажна височина е 200 мм. (3.2.) ▷

Панел или друг материал в близост до нагревателя почернява бързо.

- Проверете дали са изпълнени изискванията за безопасни разстояния (3.1.).
- Проверете камъните за сауната (1.1.). Твърде плътно натрупаните камъни, утаяването на камъните с времето или неправилният вид камък могат да попречат на въздушния поток през нагревателя, което може да доведе до прегряване на околните материали.
- Вижте също раздел 2.1.1.

Нагревателят излъчва миризма.

- Вижте раздел 1.2.
- Горещият нагревател може да подчертае миризми, смесени във въздуха, които обаче не са причинени от сауната или печката. Примери: боя, лепило, масло, подправка.

Нагревателят издава шум.

- BC: Таймерът е механично устройство и издава тиктакащ звук, когато функционира нормално. Ако таймерът тиктака дори когато нагревателят е изключен, проверете окабеляването на таймера.
- Случайните бретони най-вероятно са причинени от напукване на камъни поради топлина.
- Термичното разширение на частите на нагревателя може да причини шум, когато нагревателят се загрее.

2. SAUNA ROOM

2. САУНА

2.1. Sauna Room Structure

2.1. Структура на сауната

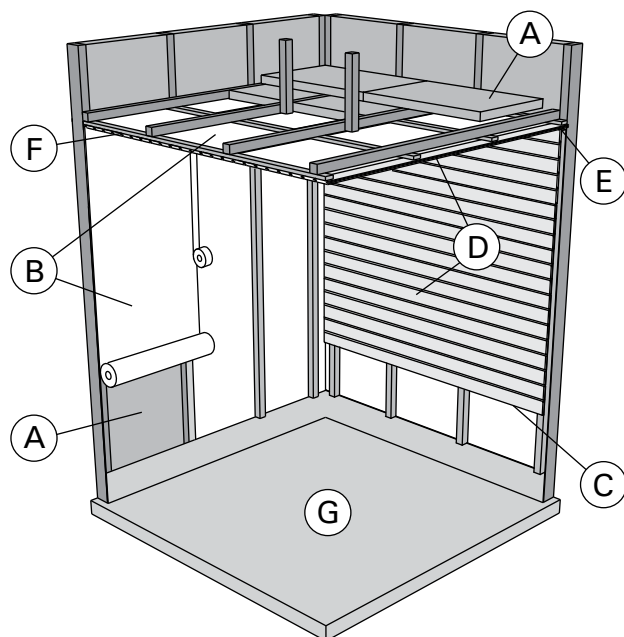

Figure 4.
Фигура 4.

- A. Insulation wool, thickness 50–100 mm. The sauna room must be insulated carefully so that the heater output can be kept moderately low.
- B. Moisture protection, e.g. aluminium paper. Place the glossy side of the paper towards the sauna. Tape the seams with aluminium tape.
- C. Vent gap of about 10 mm between the moisture protection and panel (recommendation).
- D. Low mass 12–16 mm thick panel board. Before starting the panelling, check the electric wiring and the reinforcements in the walls required by the heater and benches.
- E. Vent gap of about 3 mm between the wall and ceiling panel.
- F. The height of the sauna is usually 2100–2300 mm. The minimum height depends on the heater (see table 2). The space between the upper bench and ceiling should not exceed 1200 mm.
- G. Use floor coverings made of ceramic materials and dark joint grouts. Particles disintegrating from the sauna stones and impurities in the sauna water may stain and/or damage sensitive floor coverings.

NOTE! Check from the fire authorities which parts of the firewall can be insulated. Flues which are in use must not be insulated.

NOTE! Light protective covers which are installed directly to the wall or ceiling may be a fire risk.

2.1.1. Blackening of the sauna walls

It is perfectly normal for the wooden surfaces of the sauna room to blacken in time. The blackening may be accelerated by

- sunlight
- heat from the heater
- protective agents on the walls (protective agents have a poor heat resistance level)
- fine particles disintegrating from the sauna stones which rise with the air flow.

- A. Изолационна вата с дебелина 50–100 mm. Сауната трябва да бъде внимателно изолирана, така че мощността на нагревателя да може да се поддържа умерено ниска.
- B. В. Защита от влага, напр. алуминиева хартия. Поставете лъскавата страна на хартията към сауната. Залепете шевове с алуминиева лента.
- C. Вентилационна междина от около 10 mm между защитата от влага и панела (препоръка).
- D. Ниска маса 12–16 mm дебела плоскост. Преди да започнете облицовката, проверете електрическото окабеляване и армировките в стените, необходими за нагревателя и пейките.
- E. Вентилационна междина от около 3 mm между панела на стената и тавана.
- F. Височината на сауната обикновено е 2100–2300 mm. Минималната височина зависи от нагревателя (вижте таблица 2). Разстоянието между горната пейка и тавана не трябва да надвишава 1200 mm.
- G. Използвайте подови настилки от керамични материали и тъмни фугиращи смеси. Частиците, разпадащи се от камъните в сауната и замърсяванията във водата в сауната, могат да оцветят и/или да повредят чувствителните подови покрития.

ЗАБЕЛЕЖКА! Проверете от противопожарните власти кои части от защитната стена могат да бъдат изолирани. Димоотводите, които се използват, не трябва да се изолират.

ЗАБЕЛЕЖКА! Леките защитни капаци, които са монтирани директно към стената или тавана, могат да представляват риск от пожар.

2.1.1. Почерняване на стените на сауната

Напълно нормално е дървените повърхности на сауната да почернеят с времето. Почерняването може да се ускори от

- слънчева светлина
- топлина от нагревателя
- защитни средства по стените (защитните средства имат лошо ниво на топлоустойчивост)
- фини частици, разпадащи се от камъните на сауната, които се издигат с въздушния поток.

2.2. Sauna Room Ventilation

The air in the sauna room should change six times per hour. Figure 5 illustrates different sauna room ventilation options.

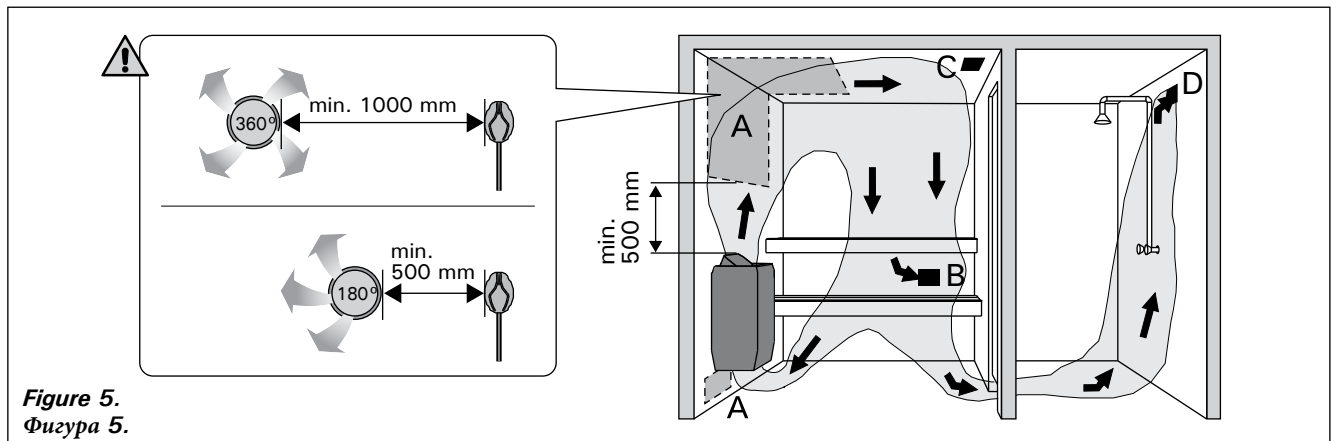

Figure 5.
Фигура 5.

- A. Supply air vent location. If mechanical exhaust ventilation is used, place the supply air vent above the heater. If gravity exhaust ventilation is used, place the supply air vent below or next to the heater. The diameter of the supply air pipe must be 50–100 mm. **BC-E: Do not place the supply air vent so that the air flow cools the temperature sensor (see the temperature sensor installation instructions in the control unit installation instructions)!**
- B. Exhaust air vent. Place the exhaust air vent near the floor, as far away from the heater as possible. The diameter of the exhaust air pipe should be twice the diameter of the supply air pipe.
- C. Optional vent for drying (closed during heating and bathing). The sauna can also be dried by leaving the door open after bathing.
- D. If the exhaust air vent is in the washroom, the gap underneath the sauna door must be at least 100 mm. Mechanical exhaust ventilation is mandatory.

2.3. Heater Output

When the walls and ceiling are covered with panels and insulation behind the panels is adequate, the heater output is defined according to the volume of the sauna. Non-insulated walls (brick, glass block, glass, concrete, tile, etc.) increase the need for heater output. Add 1,2 m³ to the volume of the sauna for each non-insulated wall square meter. For example, a 10 m³ sauna room with a glass door equals the output requirement of about a 12 m³ sauna room. If the sauna room has log walls, multiply the sauna's volume by 1,5. Choose the correct heater output from table 2.

2.4. Sauna Room Hygiene

Bench towels should be used during bathing to prevent sweat from getting onto the benches.

The benches, walls and floor of the sauna should be washed thoroughly at least every six months. Use a scrubbing brush and sauna detergent.

Wipe dust and dirt from the heater with a damp cloth. Remove lime stains from the heater using a 10% citric acid solution and rinse.

2.2. Вентилация на сауната

Сауната трябва да се проветрява шест пъти на час.

Фигура 5 илюстрира различни опции за вентилация на сауната.

- A. Местоположение на отвора за подаване на въздух. Ако се използва механична смукателна вентилация, поставете отвора за подаване на въздух над нагревателя. Ако се използва гравитационна смукателна вентилация, поставете отвора за подаване на въздух под или до нагревателя. Диаметърът на тръбата за подаване на въздух трябва да бъде 50–100 mm. **BC-E:** Не поставяйте вентилационния отвор за подаване на въздух така, че въздушният поток да охлажда температурния сензор (вижте инструкциите за монтаж на температурния сензор в инструкциите за монтаж на контролния блок)!
- B. Отдушник за отработен въздух. Поставете вентилационния отвор за отработен въздух близо до пода, възможно най-далече от нагревателя. Диаметърът на тръбата за отработен въздух трябва да бъде два пъти по-голям от диаметъра на тръбата за подаване на въздух.
- C. Допълнителен отвор за сушене (затворен по време на отопление и къпане). Сауната може да се изсуши и като оставите вратата отворена след къпане.
- D. Ако вентилационният отвор е в тоалетната, разстоянието под вратата на сауната трябва да бъде поне 100 mm. Механичната смукателна вентилация е задължителна.

2.3. Изход на нагревател

Когато стените и таванът са покрити с панели и изолацията зад панелите е подходяща, мощността на нагревателя се определя според обема на сауната. Неизолираните стени (тухли, стъклени блокове, стъкло, бетон, плочки и др.) увеличават нуждата от топлинна мощност. Добавете 1,2 m³ към обема на сауната за всеки квадратен метър неизолирана стена. Например, сауна от 10 m³ със стъклена врата се равнява на необходимата производителност на около 12 m³ сауна. Ако сауната има стени от дървени трупи, умножете обема на сауната по 1,5. Изберете правилната мощност на нагревателя от таблица 2.

2.4. Хигиена на сауната

По време на къпане трябва да се използват кърпи за пейки, за да се предотврати попадането на пот върху пейките.

Пейките, стените и пода на сауната трябва да се измиват старателно поне на всеки шест месеца. Използвайте четка за почистване и препарат за сауна.

Избършете праха и мръсотията от нагревателя с влажна кърпа. Отстранете петна от вар от нагревателя с помощта на 10% разтвор на лимонена киселина и изплакнете.

3. INSTRUCTIONS FOR INSTALLATION

3.1. Before Installation

Before installing the heater, study the instructions for installation. Check the following points:

- Is the output and type of the heater suitable for the sauna room? **The cubic volumes given in table 2 should be followed.**
- Is the supply voltage suitable for the heater?
- The location of the heater fulfils the minimum requirements concerning safety distances given in fig. 6 and table 2.

It is absolutely necessary to install the heater according to these values. Neglecting them causes a risk of fire. Only one electrical heater may be installed in the sauna room.

3. УКАЗАНИЯ ЗА МОНТАЖ

3.1. Преди инсталиране

Преди да инсталирате нагревателя, проучете инструкциите за монтаж. Проверете следните точки:

- Мощността и типът на нагревателя подходящи ли са за сауната? Трябва да се следват кубичните обеми, дадени в таблица 2.
- Подходящо ли е захранващото напрежение за нагревателя?
- Местоположението на нагревателя отговаря на минималните изисквания относно безопасните разстояния, посочени на фиг. 6 и таблица 2.

Абсолютно необходимо е нагревателят да се монтира в съответствие с тези стойности. Пренебрегването им води до риск от пожар. В сауната може да се монтира само един електрически нагревател.

Heater Нагревател	Out-put Мощност	Sauna room Сауна			Electrical connections Електрически връзки				
		Cubic vol. Кубичен об.		Height Височина	400 V 3N ~		230 V 1N ~		To sensor (BC-E) Към сензор (BC-E)
Model and dimensions/ Модел и размери		min.	max.	min.	Connecting cable Свързващ кабел	Fuse Предпазител	Connecting cable Свързващ кабел	Fuse Предпазител	
Width/ширина • BC 480 mm • BC-E 450 mm Depth/Дълбочина 310 mm Height/Височина 540 mm Weight/Тегло 11 kg Stones/Камъни max. 20 kg		▷ 2.3.			See fig. 8. The measurements apply to the connecting cable only! Вижте фиг. 8. Измерванията се отнасят само за свързващия кабел!				
	kW	m ³	m ³	mm	mm ²	A	mm ²	A	mm ²
BC45/BC45E	4,5	3	6	1900	5 x 1,5	3 x 10	3 x 2,5	1 x 20	4 x 0,25
BC60/BC60E	6,0	5	8	1900	5 x 1,5	3 x 10	3 x 2,5	1 x 35	4 x 0,25
BC80/BC80E	8,0	7	12	1900	5 x 2,5	3 x 16	3 x 6	1 x 35	4 x 0,25
BC90/BC90E	9,0	8	14	1900	5 x 2,5	3 x 16	3 x 10	1 x 50	4 x 0,25

Table 2. Installation details

Таблица 2. Подробности за монтажа

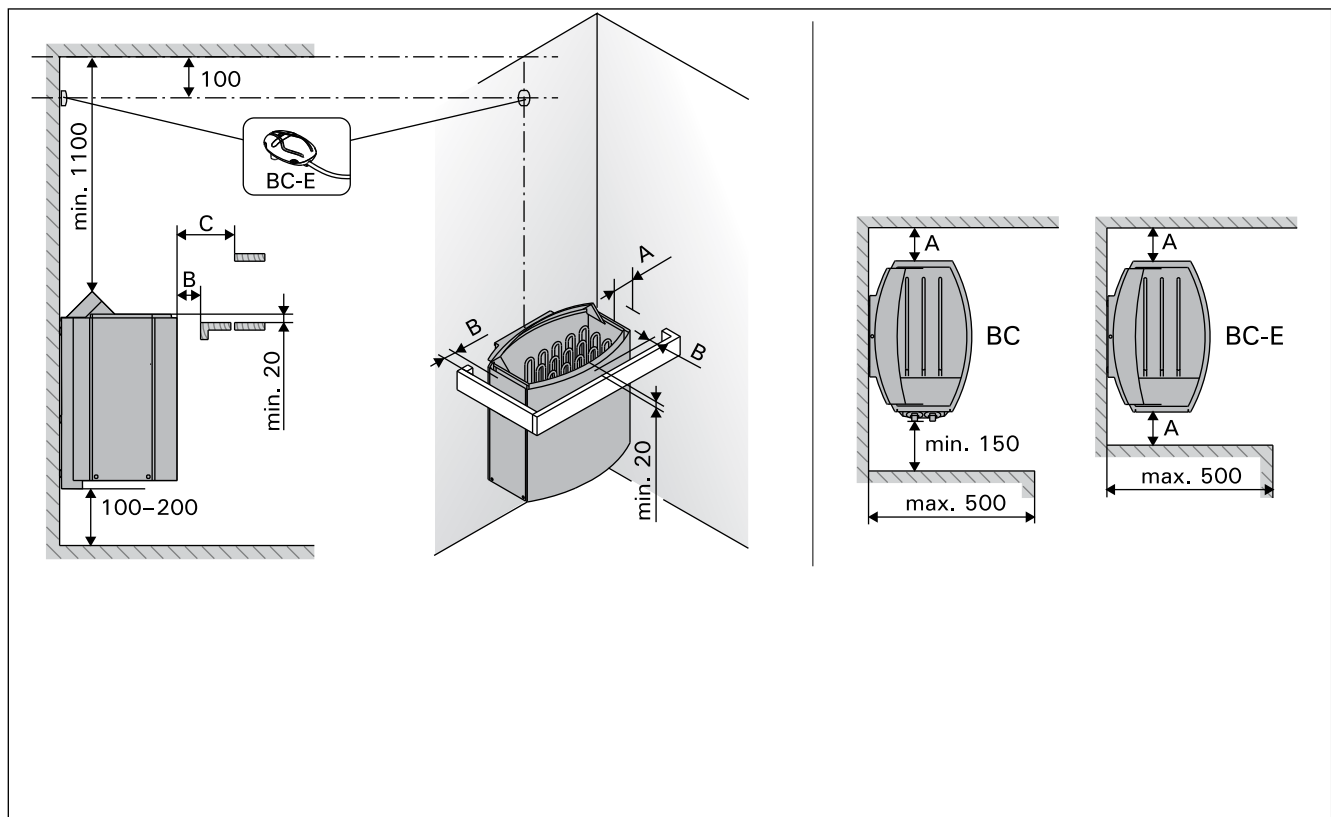

Figure 6. Safety distances (all dimensions in millimeters)

Фигура 6. Безопасни разстояния (всички размери в милиметри)

3.2. Fastening the Heater on a Wall

See figure 7.

1. Remove both cardboard covers before installation.
2. Fasten the wall-mounting rack on the wall by using the screws which come with the rack.
NOTE! There must be a support, e.g. a board, behind the panel, so that the fastening screws can be screwed into a thicker wooden material than the panel. If there are no boards behind the panel, the boards can also be fastened on the panel.
3. The right- or left-handedness of the heater can be changed by installing it to the rack correspondingly. Make sure the clip fastens in the hole properly.
4. Lift the heater to the rack on the wall so that the fastening hooks of the lower part of the rack go behind the edge of the heater body. Lock the edge of the heater onto the rack by a screw.

3.2. Закрепване на нагревателя към стена

Вижте фигура 7.

1. Преди това отстранете двата картонени капака инсталация.
2. Закрепете стойката за стенен монтаж към стената с помощта на винтовете, които се доставят с стойката.

ЗАБЕЛЕЖКА! Трябва да има опора, напр. дъска зад панела, така че закрепващите винтове да могат да се завинтват в по-дебел дървен материал от панела. Ако зад панела няма дъски, дъските могат да се закрепят и върху панела.

3. Дясната или лявата позиция на нагревателя може да бъде променена чрез съответното му монтиране към стелаж. Уверете се, че щипката е закрепена правилно в отвора.
4. Повдигнете нагревателя към стойката на стената, така че куките за закрепване на долната част на стойката да минават зад ръба на тялото на нагревателя. Заклучете ръба на нагревателя върху стойката с винт.

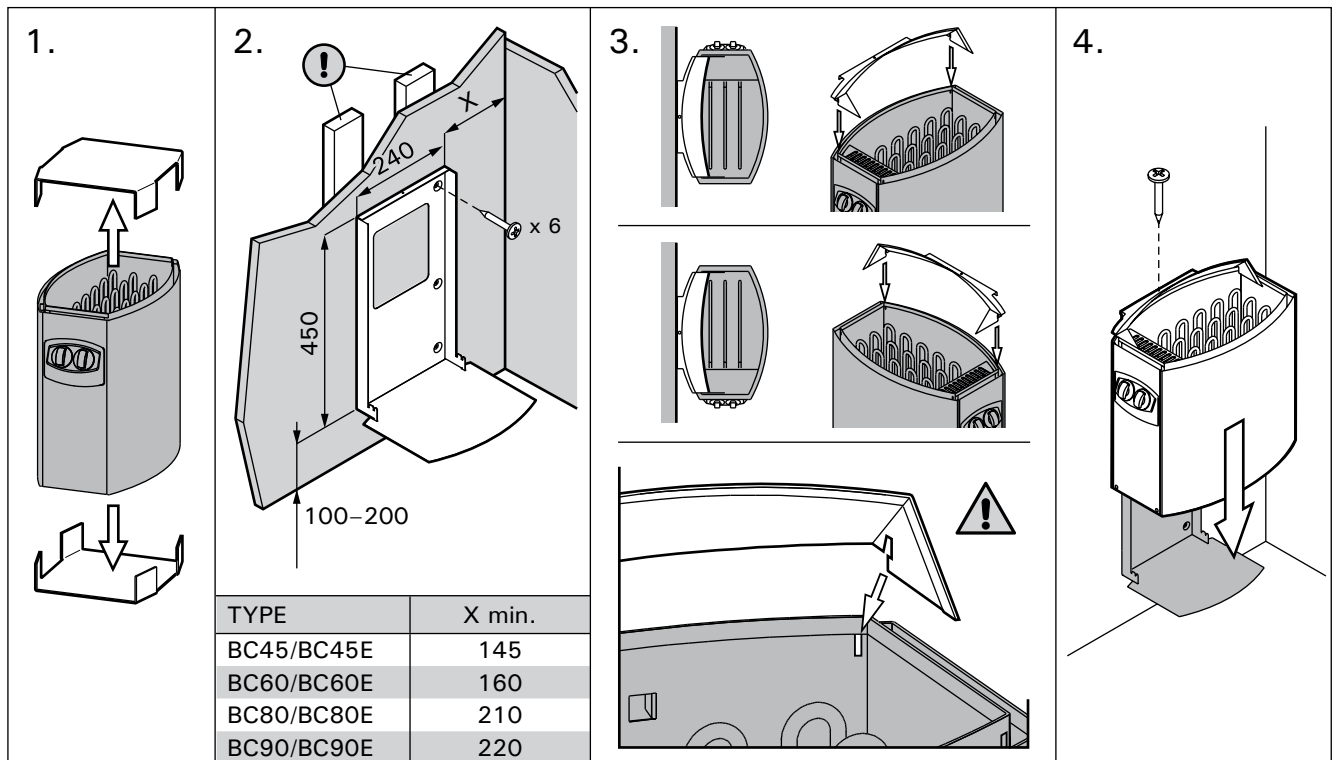

Figure 7. Fastening the heater on a wall (all dimensions in millimeters)
Фигура 7. Закрепване на нагревателя към стена (всички размери в милиметри)

3.3. Electrical Connections

The heater may only be connected to the electrical network in accordance with the current regulations by an authorised, professional electrician.

- The heater is semi-stationarily connected to the junction box (figure 8: A) on the sauna wall. The junction box must be splash-proof, and its maximum height from the floor must not exceed 500 mm.
- The connecting cable (figure 8: B) must be of rubber cable type H07RN-F or its equivalent. **NOTE! Due to thermal embrittlement, the use of PVC-insulated wire as the connecting cable of the heater is forbidden.**
- If the connecting and installation cables are higher than 1000 mm from the floor in the sauna or inside the sauna room walls, they must be able to endure a minimum temperature of 170 °C when loaded (for example, SSJ). Electrical equipment installed higher than 1000 mm from the sauna floor must be approved for use in a temperature of 125 °C (marking T125).
- In addition to supply connectors, the BC heaters are equipped with a connector (P), which makes the control of the electric heating possible (figure 10). Voltage control is transmitted from the heater when it is switched on. The control cable for electrical heating is brought directly into the junction box of the heater, and from there to the terminal block of the heater along a rubber cable with the same cross-section area as that of the connecting cable.
- **When closing the cover of the connection box make sure that the upper edge of the cover is placed correctly.** If the upper edge is misplaced water can enter the connection box. Figure 8.

3.3. Електрически връзки

Нагревателят може да бъде свързан към електрическата мрежа в съответствие с действащите разпоредби от оторизиран професионален електротехник.

- Нагревателят е полустационарно свързан към съединителната кутия (фигура 8: А) на стената на сауната. Разпределителната кутия трябва да е устойчива на пръски, а максималната ѝ височина от пода не трябва да надвишава 500 mm.
- Свързващият кабел (фигура 8: В) трябва да бъде от гумен кабел тип H07RN-F или негов еквивалент. **ЗАБЕЛЕЖКА! Поради термична крехкост, използването на проводник с PVC изолация като свързващ кабел на нагревателя е забранено.**
- Ако свързващите и инсталационните кабели са по-високи от 1000 mm от пода в сауната или вътре в стените на сауната, те трябва да могат да издържат на минимална температура от 170 °C, когато са натоварени (например SSJ). Електрическото оборудване, инсталирано на височина над 1000 mm от пода на сауната, трябва да бъде одобрено за употреба при температура от 125 °C (маркировка T125).
- В допълнение към конекторите за захранване, нагревателите BC са оборудвани с конектор (P), който прави възможно управлението на електрическото отопление (фигура 10). Контролът на напрежението се предава от нагревателя, когато е включен. Контролният кабел за електрическо отопление се извежда директно в разклонителната кутия на нагревателя, а оттам до клеморедата на нагревателя по гумен кабел със същото сечение като това на свързващия кабел.
- **Когато затваряте капака на съединителната кутия, уверете се, че горният ръб на капака е поставен правилно.** Ако горният ръб е поставен неправилно, водата може да влезе в кутията за свързване. Фигура 8.

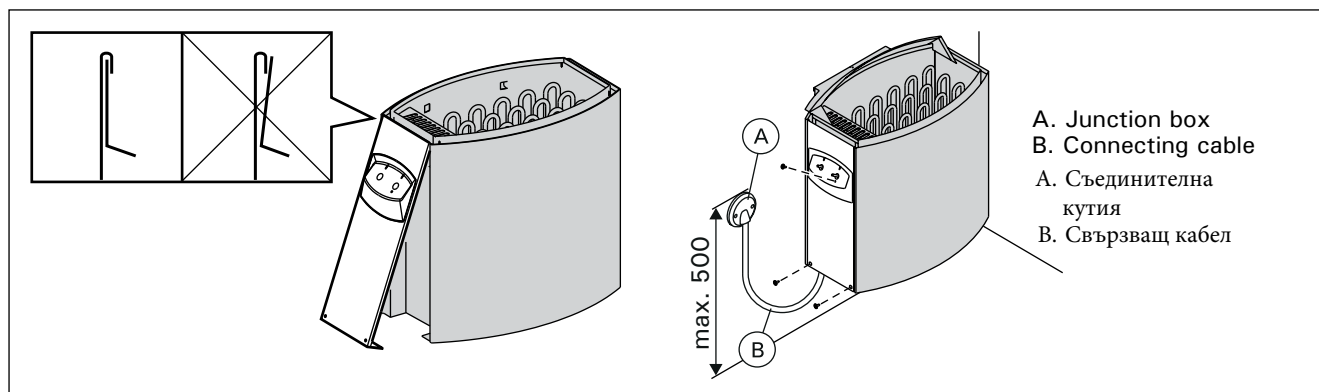

Figure 8. Closing the cover of the connection box (all dimensions in millimeters)
Фигура 8. Затваряне на капака на съединителната кутия (всички размери в милиметри)

3.3.1. Electric Heater Insulation Resistance

When performing the final inspection of the electrical installations, a "leakage" may be detected when measuring the heater's insulation resistance. The reason for this is that the insulating material of the heating elements has absorbed moisture from the air (storage, transport). After operating the heater for a few times, the moisture will be removed from the heating elements.

Do not connect the power feed for the heater through the RCD (residual current device)!

3.3.1. Съпротивление на изолацията на електрическия нагревател

При извършване на окончателната проверка на електрическите инсталации може да се открие „теч“ при измерване на съпротивлението на изолацията на нагревателя. Причината за това е, че изолационният материал на нагревателните елементи е абсорбирал влага от въздуха (съхранение, транспорт). След като включите нагревателя няколко пъти, влагата ще бъде отстранена от нагревателните елементи.

Не свързвайте захранването на нагревателя през RCD (устройство за остатъчен ток)!

3.4. Installation of the Control Unit and Sensors (BC-E)

The control unit includes detailed instructions for fastening the unit on the wall. Install the temperature sensor on the wall of the sauna room above the heater. It should be installed on the lateral centre line of the heater, 100 mm downwards from the ceiling. Figure 6.

Do not place the supply air vent so that the air flow cools the temperature sensor. Figure 5.

3.5. Resetting the Overheat Protector

If the temperature of the sauna room becomes dangerously high, the overheat protector will permanently cut off the supply of the heater. The overheat protector can be reset after the heater has cooled down.

BC

The reset button is located inside the heater's connection box (figure 9). **Only persons authorised to carry out electrical installations can reset the overheat protector.**

Prior to pressing the button, the cause of the fault must be found.

- Are the stones crumbled and pressed together?
- Has the heater been on for a long time while unused?
- Is the sensor of the thermostat out of place or broken?
- Has the heater been banged or shaken?

BC-E

See the installation instructions for control unit.

3.4. Монтаж на контролния блок и сензори (BC-E)

Блокът за управление включва подробни инструкции за закрепване на модула към стената. Монтирайте температурния сензор на стената на сауната над печката. Той трябва да се монтира на страничната централна линия на нагревателя, 100 mm надолу от тавана. Фигура 6.

Не поставяйте вентилационния отвор за подаване на въздух така, че въздушният поток да охлажда температурния сензор. Фигура 5.

3.5. Нулиране на защитата от прегряване

Ако температурата в сауната стане опасно висока, защитата от прегряване ще прекъсне завинаги захранването на нагревателя. Защитата от прегряване може да се нулира, след като нагревателят се охлади.

пр.н.е

Бутонът за нулиране се намира вътре в кутията за свързване на нагревателя (фигура 9). Само лица, упълномощени да извършват електрически инсталации, могат да нулират защитата от прегряване.

Преди да натиснете бутона, трябва да откриете причината за повредата.

- Камъните натрошени и притиснати ли са?
- Нагревателят включен ли е дълго време, без да е използван?
- Сензорът на термостата не е на място или е счупен?
- Нагревателят бил ли е удрян или разклатен?

BC-E

Вижте инструкциите за монтаж на контролния блок.

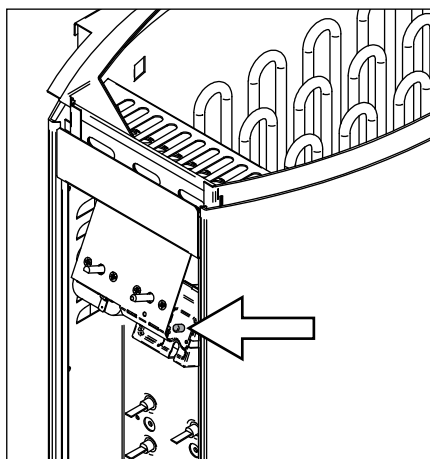

Figure 9. Reset button for overheat protector
Фигура 9. Бутон за нулиране за защита от прегряване

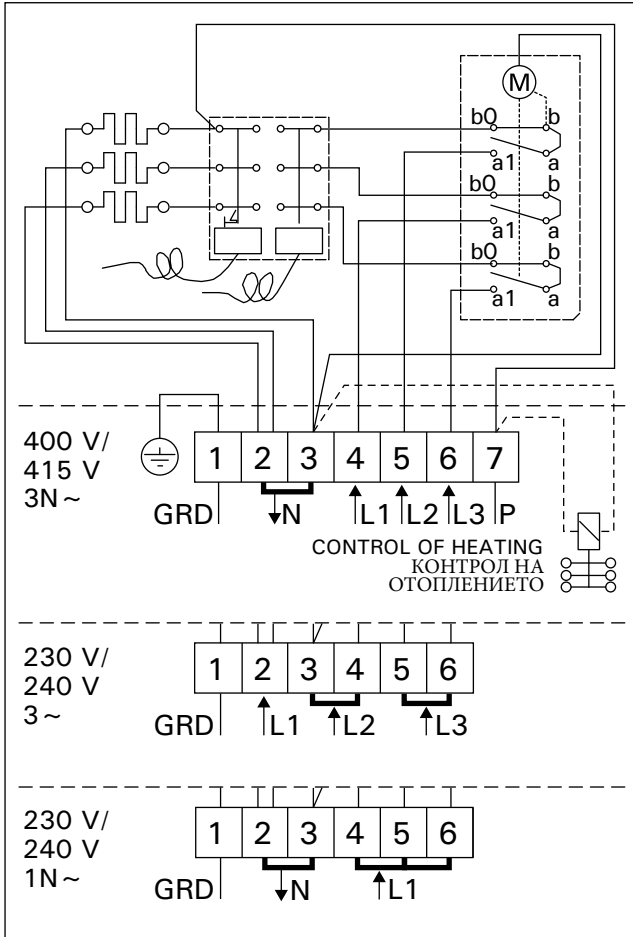

Figure 10. Electrical connections of BC heater
 Фигура 10. Електрически връзки на BC нагревател

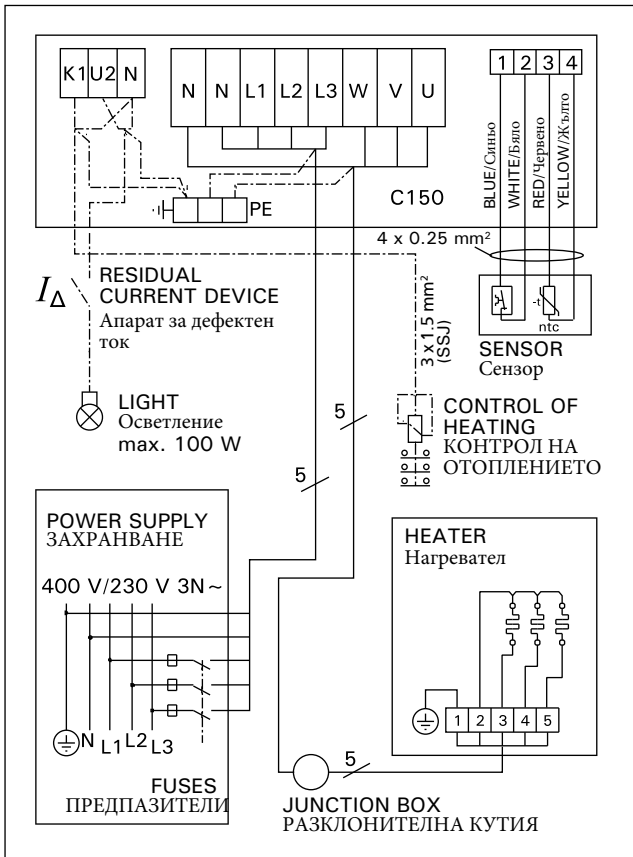

Figure 12a. 3-phase electrical connections of control unit C150 and BC-E heater
 Фигура 12а. 3-фазни електрически връзки на контролен блок C150 и нагревател BC-E

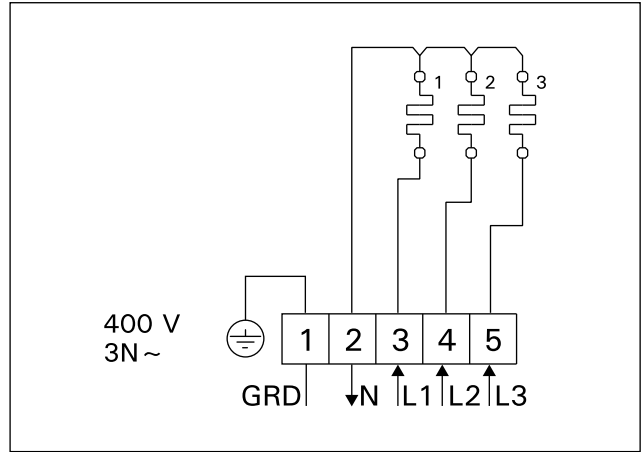

Figure 11. Electrical connections of BC-E heater
 Фигура 11. Електрически връзки на нагревател BC-E

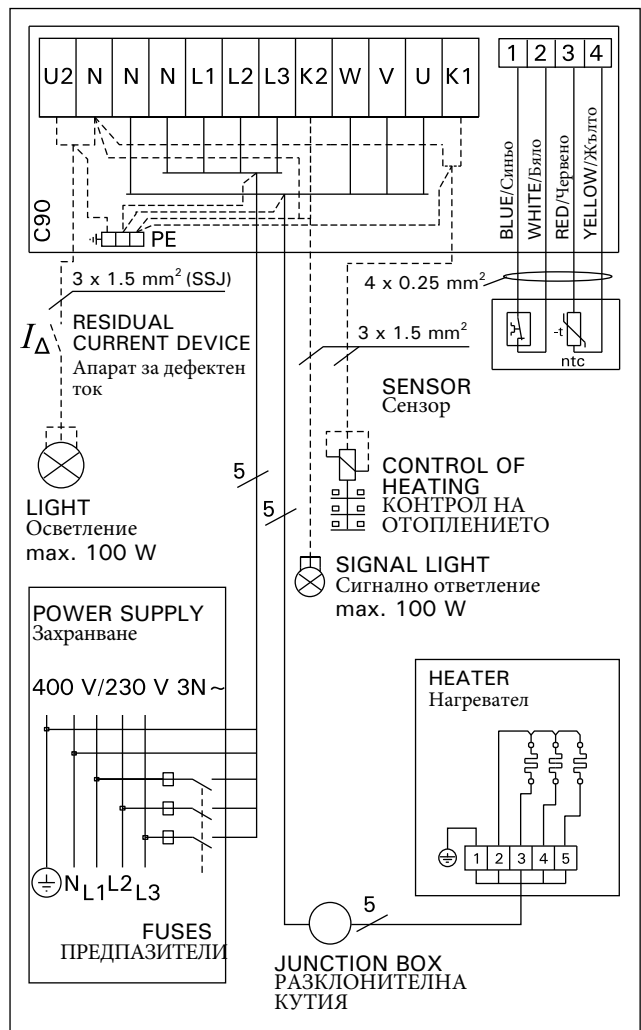

Figure 12b. 3-phase electrical connections of control unit C90 and BC-E heater
 Фигура 12б. 3-фазни електрически връзки на контролен блок C90 и нагревател BC-E

4. VARAOSAT

4. SPARE PARTS

4. ЗАПАСНЫЕ ЧАСТИ

4. REZERVES DAĻAS

4. PIÈCES DÉTACHÉES

4. CZĘŚCI ZAMIENNE

4. RESERVDELAR

4. РЕЗЕРВНИ ЧАСТИ

4. VARUOSAD

4. ATSARGINĒS DETALĒS

4. RESERVEONDERDELEN

4. NÁHRADNÍ DÍLY

1	ZSB-224	1500 W/230 V
2	ZSB-226	2000 W/230 V
3	ZSB-228	2670 W/230 V
4	ZSB-229	3000 W/230 V
5	ZSK-510	⌚ (BC)
6	ZSB-125	
7	ZSK-520	°C (BC)
8	ZSB-115	

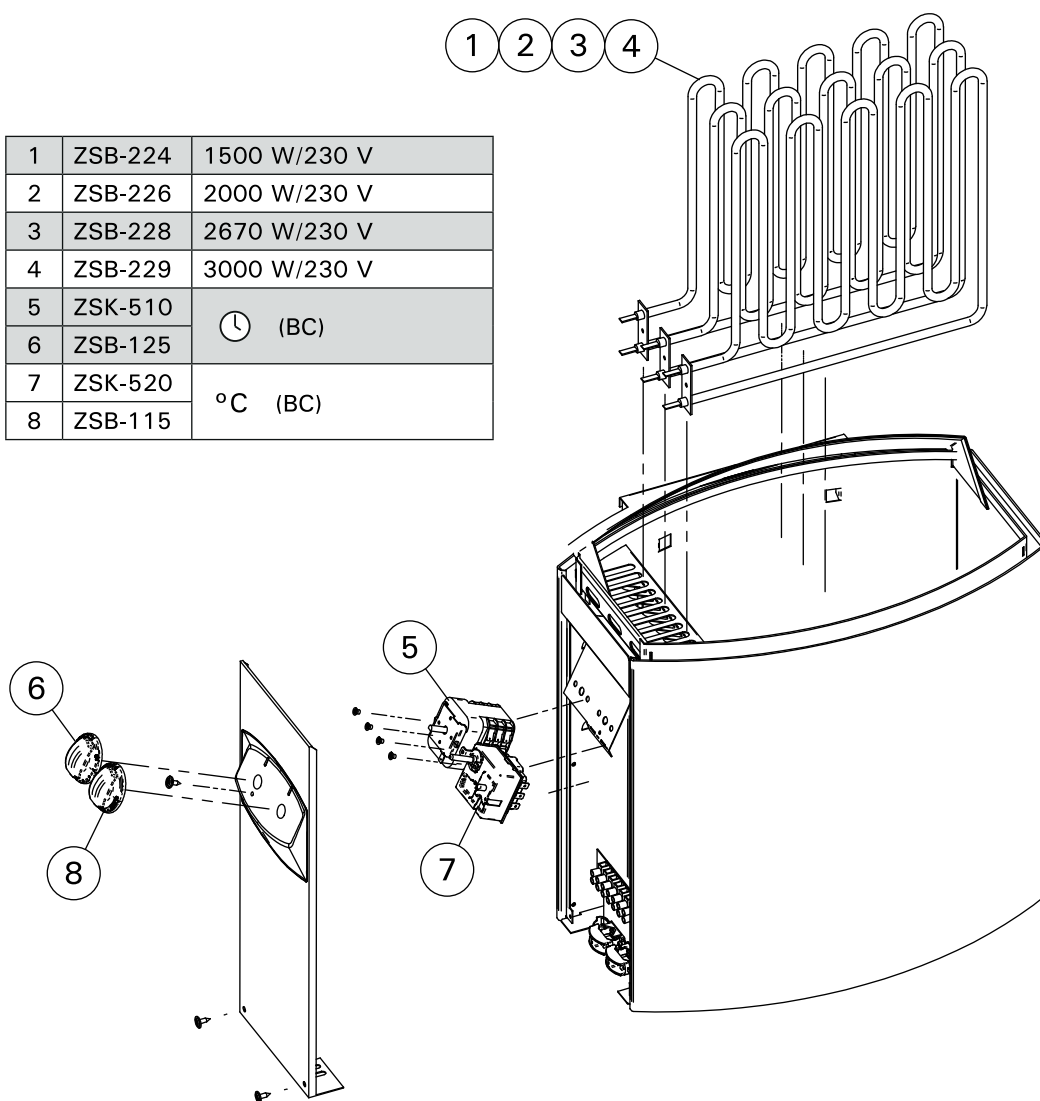

HARVIA

Harvia Oy
PL12
40951 Muurame
Finland
www.harvia.fi

BC45, BC60, BC80 BC45E, BC60E, BC80E, BC90E

EN Instructions for Installation and Use of Electric Sauna Heater

BG Инструкции за инсталиране и използване на електрическа
печка за сауна



BC



BC-E

These instructions for installation and use are intended for the owner or the person in charge of the sauna, as well as for the electrician in charge of the electrical installation of the heater. After completing the installation, the person in charge of the installation should give these instructions to the owner of the sauna or to the person in charge of its operation. Please read the instructions for use carefully before using the heater.

The heater is designed for the heating of a sauna room to bathing temperature. It is not to be used for any other purpose.

Congratulations on your choice!

Guarantee:

- The guarantee period for heaters and control equipment used in saunas by families is two (2) years.
- The guarantee period for heaters and control equipment used in saunas by building residents is one (1) year.
- The guarantee does not cover any faults resulting from failure to comply with installation, use or maintenance instructions.
- The guarantee does not cover any faults resulting from the use of stones not recommended by the heater manufacturer.

CONTENTS

1. INSTRUCTIONS FOR USE	3
1.1. Piling of the Sauna Stones.....	3
1.1.1. Maintenance.....	3
1.2. Heating of the Sauna.....	4
1.3. Using the Heater.....	4
1.3.1. Heater On.....	4
1.3.2. Pre-setting Time (timed switch-on).....	4
1.3.3. Heater Off.....	5
1.3.4. Setting the Temperature.....	5
1.4. Throwing Water on Heated Stones.....	5
1.5. Instructions for Bathing.....	6
1.6. Warnings.....	6
1.7. Troubleshooting.....	6
2. SAUNA ROOM	8
2.1. Sauna Room Structure.....	8
2.1.1. Blackening of the sauna walls.....	8
2.2. Sauna Room Ventilation.....	9
2.3. Heater Output.....	9
2.4. Sauna Room Hygiene.....	9
3. INSTRUCTIONS FOR INSTALLATION	10
3.1. Before Installation.....	10
3.2. Fastening the Heater on a Wall.....	11
3.3. Electrical Connections.....	12
3.3.1. Electric Heater Insulation Resistance.....	12
3.4. Installation of the Control Unit and Sensors (BC-E).....	13
3.5. Resetting the Overheat Protector.....	13
4. SPARE PARTS	15

Тези инструкции за монтаж и експлоатация са предназначени за собственика на сауната или лицето, отговорно за поддръжката на сауната, както и за електротехника, отговорен за инсталирането на печката за сауна. Когато печката за сауна е сглобена, тези инструкции за монтаж и експлоатация се предоставят на собственика на сауната или на лицето, отговорно за поддръжката на сауната. Прочетете внимателно инструкциите за експлоатация, преди да използвате фурната.

Печката се използва за загряване на сауната до определена температура. Използването за други цели е забранено.

Поздравяваме Ви за добрия избор!

Гаранция:

- Гаранционният срок за нагревателите и контролерите за сауна, използвани за битови цели, е две (2) години.
- Гаранционният срок за нагревателите и контролерите за сауна, използвани в обществени сауни в частни сгради, е един (1) година.
- Гаранцията не покрива дефекти, причинени от неправилен монтаж и употреба или неспазване на инструкциите за поддръжка.
- Гаранцията не покрива повреди, причинени от използване на камъни, различни от препоръчаните от фабриката.

СЪДЪРЖАНИЕ

1. ИНСТРУКЦИИ ЗА УПОТРЕБА	3
1.1. Натрупване на камъни за сауна.....	3
1.1.1. Поддръжка.....	3
1.2. Затопляне на сауната.....	4
1.3. Използване на нагревателя.....	4
1.3.1. Включен нагревател.....	4
1.3.2. Време за предварителна настройка (включване по време).....	4
1.3.3. Изключен нагревател.....	5
1.3.4. Настройване на температурата.....	5
1.4. Хвърляне на вода върху нагорещени камъни.....	5
1.5. Инструкции за къпане.....	6
1.6. Предупреждения.....	6
1.7. Отстраняване на неизправности.....	6
2. САУНА	8
2.1. Структура на помещението за сауна.....	8
2.1.1. Почерняване на стените на сауната.....	8
2.2. Вентилация на сауната.....	9
2.3. Мощност на нагревателя.....	9
2.4. Хигиена на помещението за сауна.....	9
3. ИНСТРУКЦИИ ЗА ИНСТАЛИРАНЕ	10
3.1. Преди инсталиране.....	10
3.2. Закрепване на нагревателя към стена.....	11
3.3. Електрически връзки.....	12
3.3.1. Съпротивление на изолацията на електрическия нагревател.....	12
3.4. Монтаж на управляващия блок и сензори (BC-E).....	13
3.5. Нулиране на защитата от прегряване.....	13
4. РЕЗЕРВНИ ЧАСТИ	15

1. INSTRUCTIONS FOR USE

1.1. Piling of the Sauna Stones

The piling of the sauna stones has a great effect on the functioning of the heater (figure 1).

Important information on sauna stones:

- The stones should be 5–10 cm in diameter.
- Use solely angular split-face sauna stones that are intended for use in a heater. Peridotite, olivine-dolerite and olivine are suitable stone types.
- **Neither light, porous ceramic “stones” nor soft soapstones should be used in the heater. They do not absorb enough heat when warmed up. This can result in damage in heating elements.**
- Wash off dust from the stones before piling them into the heater.

Please note when placing the stones:

- Do not drop stones into the heater.
- Do not wedge stones between the heating elements.
- Place the stones sparsely to ensure that air can circulate between them.
- Pile the stones so that they support each other instead of lying their weight on the heating elements.
- Do not form a high pile of stones on top of the heater.
- No such objects or devices should be placed inside the heater stone space or near the heater that could change the amount or direction of the air flowing through the heater.

1. РЪКОВОДСТВО ЗА ЕКСПЛОАТАЦИЯ

1.1. Поддръждане на камъни за печка за сауна

Натрупването на камъни за сауна оказва голямо влияние върху функционирането на печката (фигура 1).

Важна информация за камъните за сауна:

- Камъните трябва да са с диаметър 5–10 см.
- Използвайте само ъгливи камъни за сауна с разделено лице, които са предназначени за използване в печка. Перидотит, оливин-долерит и оливин са подходящи видове камъни.
- В нагревателя не трябва да се използват нито леки, порести керамични „камъчета“, нито меки сапунени камъни. Те не абсорбират достатъчно топлина при загряване. Това може да доведе до повреда в нагревателните елементи.
- Измийте праха от камъните, преди да ги натрупате в печката..

Моля, имайте предвид, когато поставяте камъните:

- Не пускайте камъни в печката.
- Не поставяйте камъни между нагревателните елементи
- Поставете камъните на рядко, за да осигурите циркулация на въздуха между тях.
- Натрупвайте камъните така, че да се поддържат един друг, вместо да лежат с тежестта си върху нагревателните елементи.
- Не образувайте висока купчина камъни върху печката.
- Не трябва да се поставят такива предмети или устройства в пространството на нагревателя или близо до нагревателя, които могат да променят количеството или посоката на въздуха, протичащ през нагревателя.

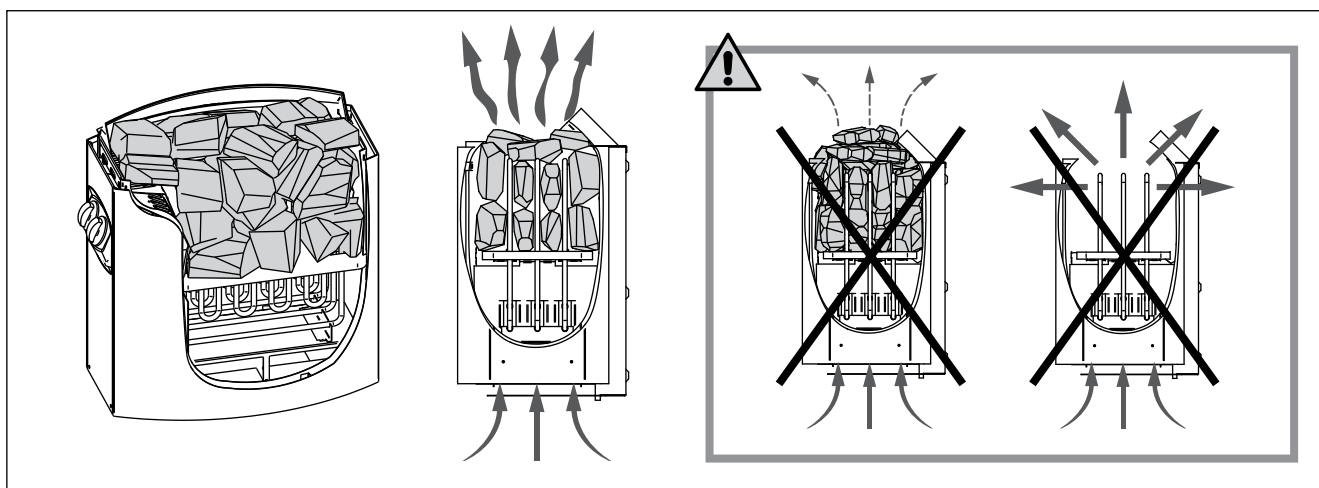

Figure 1. Piling of the sauna stones
Фигура 1. Натрупване на камъни за сауна

1.1.1. Maintenance

Due to large variation in temperature, the sauna stones disintegrate in use. Rearrange the stones at least once a year or even more often if the sauna is in frequent use. At the same time, remove any pieces of stones from the bottom of the heater and replace any disintegrated stones with new ones. By doing this, the heating capability of the heater stays optimal and the risk of overheating is avoided.

1.1.1. Поддръжка

Поради големи колебания в температурата, камъните за сауна се разпадат при употреба. Пренареждайте камъните поне веднъж годишно или дори по-често, ако сауната се използва често. В същото време отстранете всички парчета камъни от дъното на нагревателя и сменете всички разпаднали се камъни с нови. По този начин отоплителният капацитет на нагревателя остава оптимален и рискът от прегряване се избягва.

1.2. Heating of the Sauna

When operating the heater for the first time, both the heater and the stones emit smell. To remove the smell, the sauna room needs to be efficiently ventilated.

If the heater output is suitable for the sauna room, it will take about an hour for a properly insulated sauna to reach the required bathing temperature (▷ 2.3.). The sauna stones normally reach the bathing temperature at the same time as the sauna room. A suitable temperature for the sauna room is about 65–80 °C.

1.3. Using the Heater

Before switching the heater on always check that there isn't anything on top of the heater or inside the given safety distance. ▷ 1.6.

- Heater models BC45, BC60, BC80 and BC90 are equipped with a timer and a thermostat. The timer is for setting the on-time for the heater and the thermostat is for setting a suitable temperature. ▷ 1.3.1.–1.3.4.
- Heater models BC45E, BC60E, BC80E and BC90E are controlled from a separate control unit. See the instructions for use of the selected control unit model.

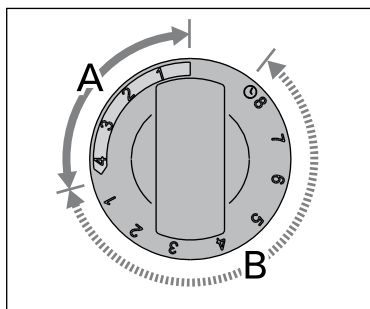

Figure 2. Timer switch
Фигура 2. Превключвател с таймер

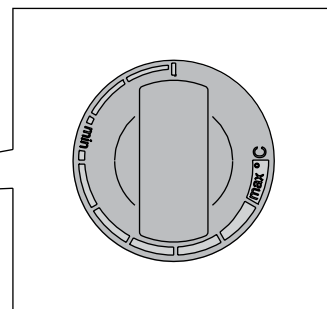
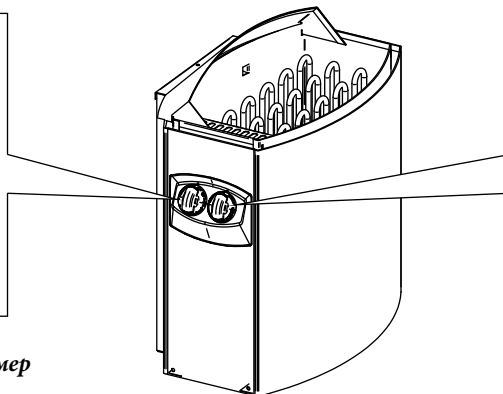
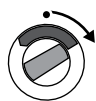

Figure 3. Thermostat switch
Фигура 3. Термостат ключ

1.3.1. Heater On



Turn the timer switch to the "on" section (section A in figure 2, 0–4 hours). The heater starts heating immediately.

1.3.2. Pre-setting Time (timed switch-on)



Turn the timer switch to the "pre-setting" section (section B in figure 2, 0–8 hours). The heater starts heating when the timer has turned the switch back to the "on" section. After this, the heater will be on for about four hours.

Example: You want to go walking for three hours and have a sauna bath after that. Turn the timer switch to the "pre-setting" section at number 2.

The timer starts. After two hours, the heater starts heating. Because it takes about one hour for the sauna to be heated, it will be ready for bathing after about three hours, that is, when you come back from your walk.

1.2. Отопление на сауната

Когато включите нагревателя за първи път, както нагревателят, така и камъните излъчват миризма. За да премахнете миризмата, помещението на сауната трябва да бъде добре вентилирано.

Ако мощността на нагревателя е подходяща за стаята със сауна, ще отнеме около час, за да достигне необходимата температура за къпане на добре изолирана сауна (2.3.). Камъните за сауна обикновено достигат температурата за къпане едновременно със сауната. Подходящата температура за сауната е около 65–80 °C.

1.3. Използване на нагревателя

Преди да включите нагревателя, винаги проверявайте дали няма нищо отгоре на нагревателя или в рамките на даденото безопасно разстояние. 1.6.

- Нагревателите модели BC45, BC60, BC80 и BC90 са оборудвани с таймер и термостат. Таймерът е за настройка на времето за включване на нагревателя, а термостатът е за задаване на подходяща температура. 1.3.1.–1.3.4.
- Нагревателите модели BC45E, BC60E, BC80E и BC90E се управляват от отделен блок за управление. Вижте инструкциите за употреба на избрания модел контролен блок.

1.3.1. Включване на нагревател

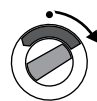

Завъртете превключвателя на таймера в положение „включено“ (секция А на фигура 2, 0–4 часа). Нагревателят започва да загрява веднага.

1.3.2. Предварителна настройка на времето (включване на таймера)



Завъртете превключвателя на таймера в раздел „предварителна настройка“ (секция В на фигура 2, 0–8 часа). Нагревателят започва да загрява, когато таймерът върне превключвателя обратно на „включено“

След това нагревателят ще работи около четири часа.

Пример: Искате да се разходжате три часа и след това да вземете сауна. Завъртете превключвателя на таймера в секцията "предварителна настройка" на номер 2.

Таймерът стартира. След два часа нагревателят започва да загрява. Тъй като загряването на сауната отнема около един час, тя ще бъде готова за къпане след около три часа, тоест когато се върнете от разходката си.

1.3.3. Heater Off



The heater switches off, when the timer turns the switch back to zero. You can switch the heater off at any time by turning the timer switch to zero yourself.

Switch the heater off after bathing. Sometimes it may be advisable to leave the heater on for a while to let the wooden parts of the sauna dry properly.

NOTE! Always check that the heater has switched off and stopped heating after the timer has turned the switch to zero.

1.3.4. Setting the Temperature

The purpose of the thermostat (figure 3) is to keep the temperature in the sauna room on a desired level. By experimenting, you can find the setting that suits you best.

Begin experimenting at the maximum position. If, during bathing, the temperature rises too high, turn the switch counter-clockwise a little. Note that even a small difference within the maximum section will change the temperature of the sauna considerably.

1.4. Throwing Water on Heated Stones

The air in the sauna room becomes dry when warmed up. Therefore, it is necessary to throw water on the heated stones to reach a suitable level of humidity in the sauna. The effect of heat and steam on people varies – by experimenting, you can find the levels of temperature and humidity that suit you best.

NOTE! The maximum volume of the ladle is 0.2 litres. If an excessive amount of water is poured on the stones, only part of it will evaporate and the rest may splash as boiling hot water on the bathers. Never throw water on the stones when there are people near the heater, because hot steam may burn their skin.

NOTE! The water to be thrown on the heated stones should meet the requirements of clean household water (table 1). Only special aromas designed for sauna water may be used. Follow the instructions given on the package.

1.3.3. Изключване на нагревателя



Нагревателят се изключва, когато таймерът върне ключа обратно на нула. Можете да изключите нагревателя по всяко време, като сами завъртите ключа на таймера на нула.

Изключете нагревателя след къпане. Понякога може да е препоръчително да оставите нагревателя включен за известно време, за да оставите дървените части на сауната да изсъхнат добре.

ЗАБЕЛЕЖКА! Винаги проверявайте дали нагревателят се е изключил и спрял да нагрява, след като таймерът е обърнал ключа на нула.

1.3.4. Настройка на температурата

Целта на термостата (фигура 3) е да поддържа температурата в сауната на желаното ниво. Като експериментирате, можете да намерите настройката, която ви подхожда най-добре.

Започнете да експериментирате от максималната позиция. Ако по време на къпане температурата се покачи твърде високо, завъртете леко ключа обратно на часовниковата стрелка. Имайте предвид, че дори малка разлика в максималната секция ще промени значително температурата на сауната

1.4. Хвърляне на вода върху нагорещени камъни

Въздухът в сауната става сух, когато се загрее. Затова е необходимо да се хвърля вода върху нагретите камъни, за да се достигне подходящо ниво на влажност в сауната. Ефектът на топлината и парата върху хората варира – като експериментирате, можете да намерите нивата на температура и влажност, които ви подхождат най-добре.

ЗАБЕЛЕЖКА! Максималният обем на черпака е 0,2 литра. Ако върху камъните се излее прекалено много вода, само част от нея ще се изпари, а останалата част може да пръсне като вряла вода върху къпещите се. Никога не хвърляйте вода върху камъните, когато в близост до печката има хора, защото горещата пара може да изгори кожата им.

ЗАБЕЛЕЖКА! Водата, която се налива върху нагорещените камъни трябва да отговаря на изискванията за чиста битова вода (таблица 1). Могат да се използват само специални аромати, предназначени за вода в сауна. Следвайте инструкциите на опаковката.

Water property Свойство на водата	Effect Ефект	Recommendation Препоръка
Humus concentration Концентрация на хумус	Colour, taste, precipitates Цвят, вкус, утайки	< 12 mg/l
Iron concentration Концентрация на желязо	Colour, odour, taste, precipitates Цвят, мирис, вкус, утайка	< 0,2 mg/l
Hardness: most important substances are manganese (Mn) and lime, i.e. calcium (Ca). Твърдост: най-важните вещества са манган (Mn) и вар, т.е. калций (Ca).	Precipitates Утаява	Mn: < 0,05 mg/l Ca: < 100 mg/l
Chlorinated water Хлорирана вода	Health risk Риск за здравето	Forbidden to use Забранено за използване
Seawater Морска вода	Rapid corrosion Бърза корозия	Forbidden to use Забранено за използване

Table 1. Water quality requirements
Таблица 1. Изисквания за качеството на водата

1.5. Instructions for Bathing

- Begin by washing yourself.
- Stay in the sauna for as long as you feel comfortable.
- Forget all your troubles and relax.
- According to established sauna conventions, you must not disturb other bathers by speaking in a loud voice.
- Do not force other bathers from the sauna by throwing excessive amounts of water on the stones.
- Cool your skin down as necessary. If you are in good health, you can have a swim if a swimming place or pool is available.
- Wash yourself after bathing.
- Rest for a while and let your pulse go back to normal. Have a drink of fresh water or a soft drink to bring your fluid balance back to normal.

1.6. Warnings

- **Staying in the hot sauna for long periods of time makes the body temperature rise, which may be dangerous.**
- **Keep away from the heater when it is hot. The stones and outer surface of the heater may burn your skin.**
- **Keep children away from the heater.**
- **Do not let young, handicapped or ill people bathe in the sauna on their own.**
- **Consult your doctor about any health-related limitations to bathing.**
- **Consult your child welfare clinic about taking little babies to the sauna.**
- **Be very careful when moving in the sauna, as the platform and floors may be slippery.**
- **Never go to a hot sauna if you have taken alcohol, strong medicines or narcotics.**
- **Never sleep in a hot sauna.**
- **Sea air and a humid climate may corrode the metal surfaces of the heater.**
- **Do not hang clothes to dry in the sauna, as this may cause a risk of fire. Excessive moisture content may also cause damage to the electrical equipment.**

1.7. Troubleshooting

Note! All service operations must be done by professional maintenance personnel.

The heater does not heat.

- Check that the fuses to the heater are in good condition.
- Check that the connection cable is connected (▷ 3.3.).
- Turn the timer switch to the "on" section (▷ 1.3.1.).
- Turn the thermostat to a higher setting (▷ 1.3.4.).
- Check that the overheat protector has not gone off. The timer works but the heater does not heat. (▷ 3.5.)

The sauna room heats slowly. The water thrown on the sauna stones cools down the stones quickly.

- Check that the fuses to the heater are in good

1.5. Инструкции за къпане

- Започнете, като се измиете.
- Останете в сауната толкова дълго, колкото се чувствате комфортно.
- Забравете всичките си проблеми и се отпуснете.
- Съгласно установените конвенции за сауната, не трябва да безпокоите другите къпеещи се, като говорите на висок глас.
- Не принуждавайте другите къпеещи се да напуснат сауната, като изхвърляте прекалено много вода върху камъните.
- Охладете кожата си, ако е необходимо. Ако сте в добро здраве, можете да плувате, ако има място за плуване или басейн.
- Измийте се след къпане.
- Починете си известно време и оставете пулса си да се нормализира. Изпийте прясна вода или безалкохолна напитка, за да върнете баланса на течностите си в норма.

1.6. Предупреждения

- **Продължителният престой в горещата сауна води до повишаване на телесната температура, което може да бъде опасно.**
- **Дръжте далече от нагревателя, когато е горещ. Камъните и външната повърхност на нагревателя могат да изгорят кожата ви.**
- **Дръжте децата далеч от печката.**
- **Не позволявайте на млади, инвалиди или болни хора да се къпят сами в сауната.**
- **Консултирайте се с вашия лекар за всякакви здравословни ограничения за къпане.**
- **Консултирайте се с вашата детска клиника относно воденето на малки бебета на сауна.**
- **Бъдете много внимателни, когато се движите в сауната, тъй като платформата и подовите може да са хлъзгави.**
- **Никога не ходете на гореща сауна, ако сте приемали алкохол, силни лекарства или наркотици.**
- **Никога не спете в гореща сауна.**
- **Морският въздух и влажният климат могат да корозират металните повърхности на нагревателя.**
- **Не окачвайте дрехи за сушене в сауната, тъй като това може да доведе до опасност от пожар. Прекомерното съдържание на влага може също да причини повреда на електрическото оборудване.**

1.7. Забележка за отстраняване на неизправности!

Всички сервизни операции трябва да се извършват от професионален персонал по поддръжката.

Нагревателят не загрява.

- Проверете дали предпазителите към нагревателя са в добро състояние.
- Проверете дали свързващият кабел е свързан (3.3.). ▷
- Завъртете превключвателя на таймера в положение "включено" ▷
- (1.3.1.).
- Завъртете термостата на по-висока настройка
- (1.3.4.).
- Проверете дали предпазителят от прегряване не се е задействал. Таймерът работи, но нагревателят не загрява. (3.5.)

Сауната се нагрява бавно. Водата, излята върху камъните за сауна, бързо охлажда камъните.

condition.

- Check that all heating elements glow when the heater is on.
- Turn the thermostat to a higher setting (▷ 1.3.4.).
- Check that the heater output is sufficient (▷ 2.3.).
- Check the sauna stones (▷ 1.1.). Too tightly piled stones, the settling of stones with time or wrong stone type can hinder the air flow through the heater, which results in reduced heating efficiency.
- Check that the sauna room ventilation has been arranged correctly (▷ 2.2.).

The sauna room heats quickly, but the temperature of the stones remain insufficient.

Water thrown on the stones runs through.

- Turn the thermostat to a lower setting (▷ 1.3.4.).
- Check that the heater output is not too high (▷ 2.3.).
- Check that the sauna room ventilation has been arranged correctly (▷ 2.2.).

The sauna room heats unevenly.

- Check that the heater has been installed in the correct height. The heater heats the sauna best, when it is installed 100 mm from the floor. The maximum installation height is 200 mm. (▷ 3.2.)

Panel or other material near the heater blackens quickly.

- Check that the requirements for safety distances are fulfilled (▷ 3.1.).
- Check the sauna stones (▷ 1.1.). Too tightly piled stones, the settling of stones with time or wrong stone type can hinder the air flow through the heater, which may result in overheating of surrounding materials.
- Also see section 2.1.1.

The heater emits smell.

- See section 1.2.
- The hot heater may emphasize odours mixed in the air that are not, however, caused by the sauna or the heater. Examples: paint, glue, oil, seasoning.

The heater makes noise.

- BC: The timer is a mechanical device and it makes a ticking sound when it is functioning normally. If the timer ticks even when the heater is switched off, check the timer's wiring.
- Occasional bangs are most likely caused by stones cracking due to heat.
- The thermal expansion of heater parts can cause noises when the heater warms up.

- Проверете дали предпазителите към нагревателя са в добро състояние
- Проверете дали всички нагревателни елементи светят, когато нагревателят е включен.
- Завъртете термостата на по-висока настройка (1.3.4.). ▷
- Проверете дали мощността на нагревателя е достатъчна ▷
- (2.3.). ▷
- Проверете камъните за сауната (1.1.). Твърде плътно натрупаните камъни, утаяването на камъните с времето или грешният вид камъни могат да възпрепятстват въздушния поток през нагревателя, което води до намалена ефективност на отоплението.
- Проверете дали вентилацията на сауната е ▷ подредена правилно (2.2.).

Сауната се затопля бързо, но температурата на камъните остава недостатъчна. Водата, хвърлена върху камъните, тече.

- Завъртете термостата на по-ниска настройка (1.3.4.). ▷
- Проверете дали мощността на нагревателя не е твърде висока (2.3.).
- Проверете дали вентилацията на сауната е ▷ подредена правилно (2.2.).

Сауната се нагрива неравномерно.

- Проверете дали нагревателят е монтиран в правилната височина. Печката загрява най-добре сауната, когато е монтирана на 100 мм от пода. Максималната монтажна височина е 200 мм. (3.2.) ▷

Панел или друг материал в близост до нагревателя почернява бързо.

- Проверете дали са изпълнени изискванията за безопасни разстояния (3.1.).
- Проверете камъните за сауната (1.1.). Твърде плътно натрупаните камъни, утаяването на камъните с времето или неправилният вид камък могат да попречат на въздушния поток през нагревателя, което може да доведе до прегряване на околните материали.
- Вижте също раздел 2.1.1.

Нагревателят излъчва миризма.

- Вижте раздел 1.2.
- Горещият нагревател може да подчертае миризми, смесени във въздуха, които обаче не са причинени от сауната или печката. Примери: боя, лепило, масло, подправка.

Нагревателят издава шум.

- BC: Таймерът е механично устройство и издава тиктакащ звук, когато функционира нормално. Ако таймерът тиктака дори когато нагревателят е изключен, проверете окабеляването на таймера.
- Случайните бретони най-вероятно са причинени от напукване на камъни поради топлина.
- Термичното разширение на частите на нагревателя може да причини шум, когато нагревателят се загрее.

2. SAUNA ROOM

2. САУНА

2.1. Sauna Room Structure

2.1. Структура на сауната

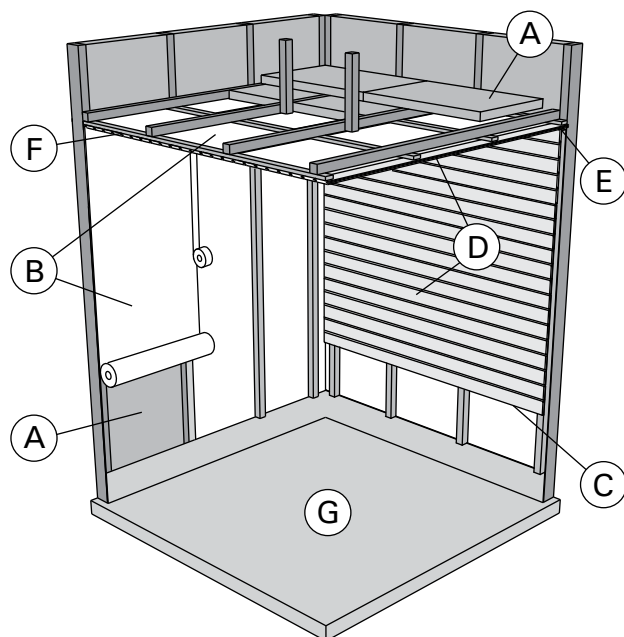

Figure 4.
Фигура 4.

- A. Insulation wool, thickness 50–100 mm. The sauna room must be insulated carefully so that the heater output can be kept moderately low.
- B. Moisture protection, e.g. aluminium paper. Place the glossy side of the paper towards the sauna. Tape the seams with aluminium tape.
- C. Vent gap of about 10 mm between the moisture protection and panel (recommendation).
- D. Low mass 12–16 mm thick panel board. Before starting the panelling, check the electric wiring and the reinforcements in the walls required by the heater and benches.
- E. Vent gap of about 3 mm between the wall and ceiling panel.
- F. The height of the sauna is usually 2100–2300 mm. The minimum height depends on the heater (see table 2). The space between the upper bench and ceiling should not exceed 1200 mm.
- G. Use floor coverings made of ceramic materials and dark joint grouts. Particles disintegrating from the sauna stones and impurities in the sauna water may stain and/or damage sensitive floor coverings.

NOTE! Check from the fire authorities which parts of the firewall can be insulated. Flues which are in use must not be insulated.

NOTE! Light protective covers which are installed directly to the wall or ceiling may be a fire risk.

2.1.1. Blackening of the sauna walls

It is perfectly normal for the wooden surfaces of the sauna room to blacken in time. The blackening may be accelerated by

- sunlight
- heat from the heater
- protective agents on the walls (protective agents have a poor heat resistance level)
- fine particles disintegrating from the sauna stones which rise with the air flow.

- A. Изолационна вата с дебелина 50–100 mm. Сауната трябва да бъде внимателно изолирана, така че мощността на нагревателя да може да се поддържа умерено ниска.
- B. В. Защита от влага, напр. алуминиева хартия. Поставете лъскавата страна на хартията към сауната. Залепете шевове с алуминиева лента.
- C. Вентилационна междина от около 10 mm между защитата от влага и панела (препоръка).
- D. Ниска маса 12–16 mm дебела плоскост. Преди да започнете облицовката, проверете електрическото окабеляване и армировките в стените, необходими за нагревателя и пейките.
- E. Вентилационна междина от около 3 mm между панела на стената и тавана.
- F. Височината на сауната обикновено е 2100–2300 mm. Минималната височина зависи от нагревателя (вижте таблица 2). Разстоянието между горната пейка и тавана не трябва да надвишава 1200 mm.
- G. Използвайте подови настилки от керамични материали и тъмни фугиращи смеси. Частиците, разпадащи се от камъните в сауната и замърсяванията във водата в сауната, могат да оцветят и/или да повредят чувствителните подови покрития.

ЗАБЕЛЕЖКА! Проверете от противопожарните власти кои части от защитната стена могат да бъдат изолирани. Димоотводите, които се използват, не трябва да се изолират.

ЗАБЕЛЕЖКА! Леките защитни капаци, които са монтирани директно към стената или тавана, могат да представляват риск от пожар.

2.1.1. Почерняване на стените на сауната

Напълно нормално е дървените повърхности на сауната да почернеят с времето. Почерняването може да се ускори от

- слънчева светлина
- топлина от нагревателя
- защитни средства по стените (защитните средства имат лошо ниво на топлоустойчивост)
- фини частици, разпадащи се от камъните на сауната, които се издигат с въздушния поток.

2.2. Sauna Room Ventilation

The air in the sauna room should change six times per hour. Figure 5 illustrates different sauna room ventilation options.

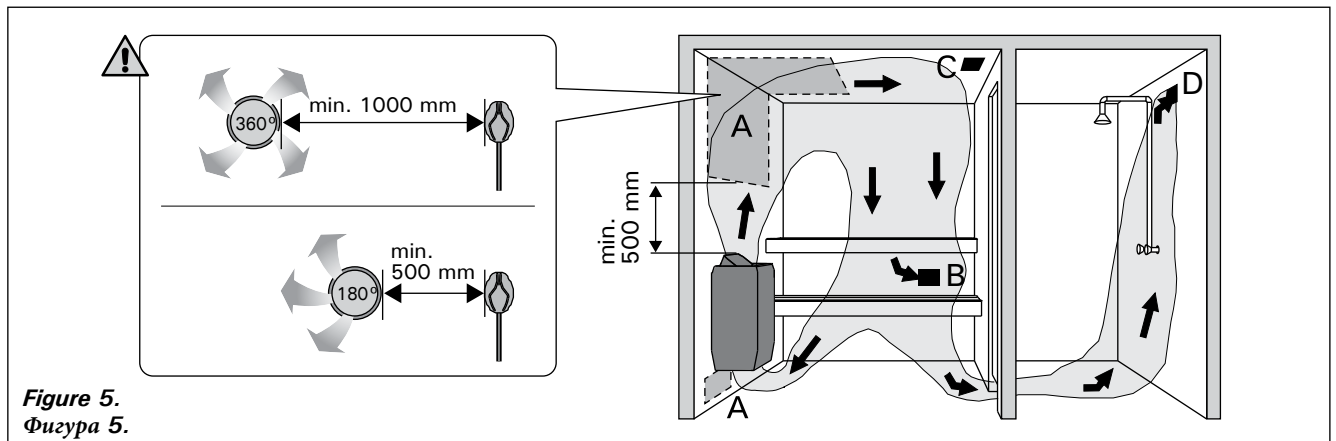

Figure 5.
Фигура 5.

- A. Supply air vent location. If mechanical exhaust ventilation is used, place the supply air vent above the heater. If gravity exhaust ventilation is used, place the supply air vent below or next to the heater. The diameter of the supply air pipe must be 50–100 mm. **BC-E: Do not place the supply air vent so that the air flow cools the temperature sensor (see the temperature sensor installation instructions in the control unit installation instructions)!**
- B. Exhaust air vent. Place the exhaust air vent near the floor, as far away from the heater as possible. The diameter of the exhaust air pipe should be twice the diameter of the supply air pipe.
- C. Optional vent for drying (closed during heating and bathing). The sauna can also be dried by leaving the door open after bathing.
- D. If the exhaust air vent is in the washroom, the gap underneath the sauna door must be at least 100 mm. Mechanical exhaust ventilation is mandatory.

2.3. Heater Output

When the walls and ceiling are covered with panels and insulation behind the panels is adequate, the heater output is defined according to the volume of the sauna. Non-insulated walls (brick, glass block, glass, concrete, tile, etc.) increase the need for heater output. Add 1,2 m³ to the volume of the sauna for each non-insulated wall square meter. For example, a 10 m³ sauna room with a glass door equals the output requirement of about a 12 m³ sauna room. If the sauna room has log walls, multiply the sauna's volume by 1,5. Choose the correct heater output from table 2.

2.4. Sauna Room Hygiene

Bench towels should be used during bathing to prevent sweat from getting onto the benches.

The benches, walls and floor of the sauna should be washed thoroughly at least every six months. Use a scrubbing brush and sauna detergent.

Wipe dust and dirt from the heater with a damp cloth. Remove lime stains from the heater using a 10% citric acid solution and rinse.

2.2. Вентилация на сауната

Сауната трябва да се проветрява шест пъти на час.

Фигура 5 илюстрира различни опции за вентилация на сауната.

- A. Местоположение на отвора за подаване на въздух. Ако се използва механична смукателна вентилация, поставете отвора за подаване на въздух над нагревателя. Ако се използва гравитационна смукателна вентилация, поставете отвора за подаване на въздух под или до нагревателя. Диаметърът на тръбата за подаване на въздух трябва да бъде 50–100 mm. BC-E: Не поставяйте вентилационния отвор за подаване на въздух така, че въздушният поток да охлажда температурния сензор (вижте инструкциите за монтаж на температурния сензор в инструкциите за монтаж на контролния блок)!
- B. Отдушник за отработен въздух. Поставете вентилационния отвор за отработен въздух близо до пода, възможно най-далече от нагревателя. Диаметърът на тръбата за отработен въздух трябва да бъде два пъти по-голям от диаметъра на тръбата за подаване на въздух.
- C. Допълнителен отвор за сушене (затворен по време на отопление и къпане). Сауната може да се изсуши и като оставите вратата отворена след къпане.
- D. Ако вентилационният отвор е в тоалетната, разстоянието под вратата на сауната трябва да бъде поне 100 mm. Механичната смукателна вентилация е задължителна.

2.3. Изход на нагревател

Когато стените и таванът са покрити с панели и изолацията зад панелите е подходяща, мощността на нагревателя се определя според обема на сауната. Неизолираните стени (тухли, стъклени блокове, стъкло, бетон, плочки и др.) увеличават нуждата от топлинна мощност. Добавете 1,2 m³ към обема на сауната за всеки квадратен метър неизолирана стена. Например, сауна от 10 m³ със стъклена врата се равнява на необходимата производителност на около 12 m³ сауна. Ако сауната има стени от дървени трупи, умножете обема на сауната по 1,5. Изберете правилната мощност на нагревателя от таблица 2.

2.4. Хигиена на сауната

По време на къпане трябва да се използват кърпи за пейки, за да се предотврати попадането на пот върху пейките.

Пейките, стените и пода на сауната трябва да се измиват старателно поне на всеки шест месеца. Използвайте четка за почистване и препарат за сауна.

Избършете праха и мръсотията от нагревателя с влажна кърпа. Отстранете петна от вар от нагревателя с помощта на 10% разтвор на лимонена киселина и изплакнете.

3. INSTRUCTIONS FOR INSTALLATION

3.1. Before Installation

Before installing the heater, study the instructions for installation. Check the following points:

- Is the output and type of the heater suitable for the sauna room? **The cubic volumes given in table 2 should be followed.**
- Is the supply voltage suitable for the heater?
- The location of the heater fulfils the minimum requirements concerning safety distances given in fig. 6 and table 2.

It is absolutely necessary to install the heater according to these values. Neglecting them causes a risk of fire. Only one electrical heater may be installed in the sauna room.

3. УКАЗАНИЯ ЗА МОНТАЖ

3.1. Преди инсталиране

Преди да инсталирате нагревателя, проучете инструкциите за монтаж. Проверете следните точки:

- Мощността и типът на нагревателя подходящи ли са за сауната? Трябва да се следват кубичните обеми, дадени в таблица 2.
- Подходящо ли е захранващото напрежение за нагревателя?
- Местоположението на нагревателя отговаря на минималните изисквания относно безопасните разстояния, посочени на фиг. 6 и таблица 2.

Абсолютно необходимо е нагревателят да се монтира в съответствие с тези стойности. Пренебрегването им води до риск от пожар. В сауната може да се монтира само един електрически нагревател.

Heater Нагревател	Out-put Мощност	Sauna room Сауна			Electrical connections Електрически връзки					
		Cubic vol. Кубичен об.		Height Височина	400 V 3N~ Connecting cable Свързващ кабел		Fuse Предпазител	230 V 1N~ Connecting cable Свързващ кабел		Fuse Предпазител
Model and dimensions/ Модел и размери		min. m ³	max. m ³	min. mm	mm ²	A	mm ²	A	mm ²	
Width/ширина • BC 480 mm • BC-E 450 mm Depth/Дълбочина 310 mm Height/Височина 540 mm Weight/Тегло 11 kg Stones/Камъни max. 20 kg		▷ 2.3.			See fig. 8. The measurements apply to the connecting cable only! Вижте фиг. 8. Измерванията се отнасят само за свързващия кабел!					
BC45/BC45E	4,5	3	6	1900	5 x 1,5	3 x 10	3 x 2,5	1 x 20	4 x 0,25	
BC60/BC60E	6,0	5	8	1900	5 x 1,5	3 x 10	3 x 2,5	1 x 35	4 x 0,25	
BC80/BC80E	8,0	7	12	1900	5 x 2,5	3 x 16	3 x 6	1 x 35	4 x 0,25	
BC90/BC90E	9,0	8	14	1900	5 x 2,5	3 x 16	3 x 10	1 x 50	4 x 0,25	

Table 2. Installation details

Таблица 2. Подробности за монтажа

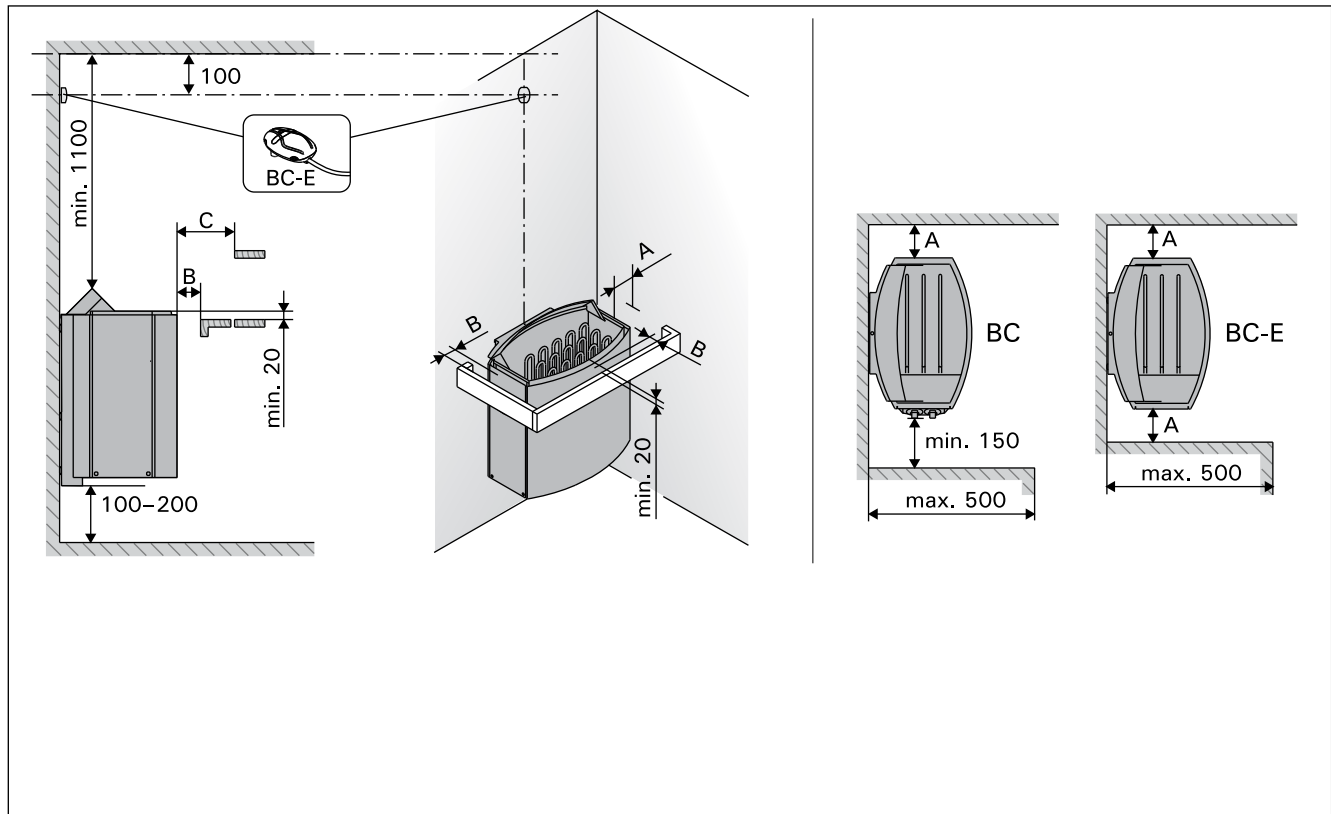

Figure 6. Safety distances (all dimensions in millimeters)

Фигура 6. Безопасни разстояния (всички размери в милиметри)

3.2. Fastening the Heater on a Wall

See figure 7.

1. Remove both cardboard covers before installation.
2. Fasten the wall-mounting rack on the wall by using the screws which come with the rack.
NOTE! There must be a support, e.g. a board, behind the panel, so that the fastening screws can be screwed into a thicker wooden material than the panel. If there are no boards behind the panel, the boards can also be fastened on the panel.
3. The right- or left-handedness of the heater can be changed by installing it to the rack correspondingly. Make sure the clip fastens in the hole properly.
4. Lift the heater to the rack on the wall so that the fastening hooks of the lower part of the rack go behind the edge of the heater body. Lock the edge of the heater onto the rack by a screw.

3.2. Закрепване на нагревателя към стена

Вижте фигура 7.

1. Преди това отстранете двата картонени капака инсталация.
2. Закрепете стойката за стенен монтаж към стената с помощта на винтовете, които се доставят с стойката.

ЗАБЕЛЕЖКА! Трябва да има опора, напр. дъска зад панела, така че закрепващите винтове да могат да се завинтват в по-дебел дървен материал от панела. Ако зад панела няма дъски, дъските могат да се закрепят и върху панела.

3. Дясната или лявата позиция на нагревателя може да бъде променена чрез съответното му монтиране към стелаж. Уверете се, че щипката е закрепена правилно в отвора.
4. Повдигнете нагревателя към стойката на стената, така че куките за закрепване на долната част на стойката да минават зад ръба на тялото на нагревателя. Заклучете ръба на нагревателя върху стойката с винт.

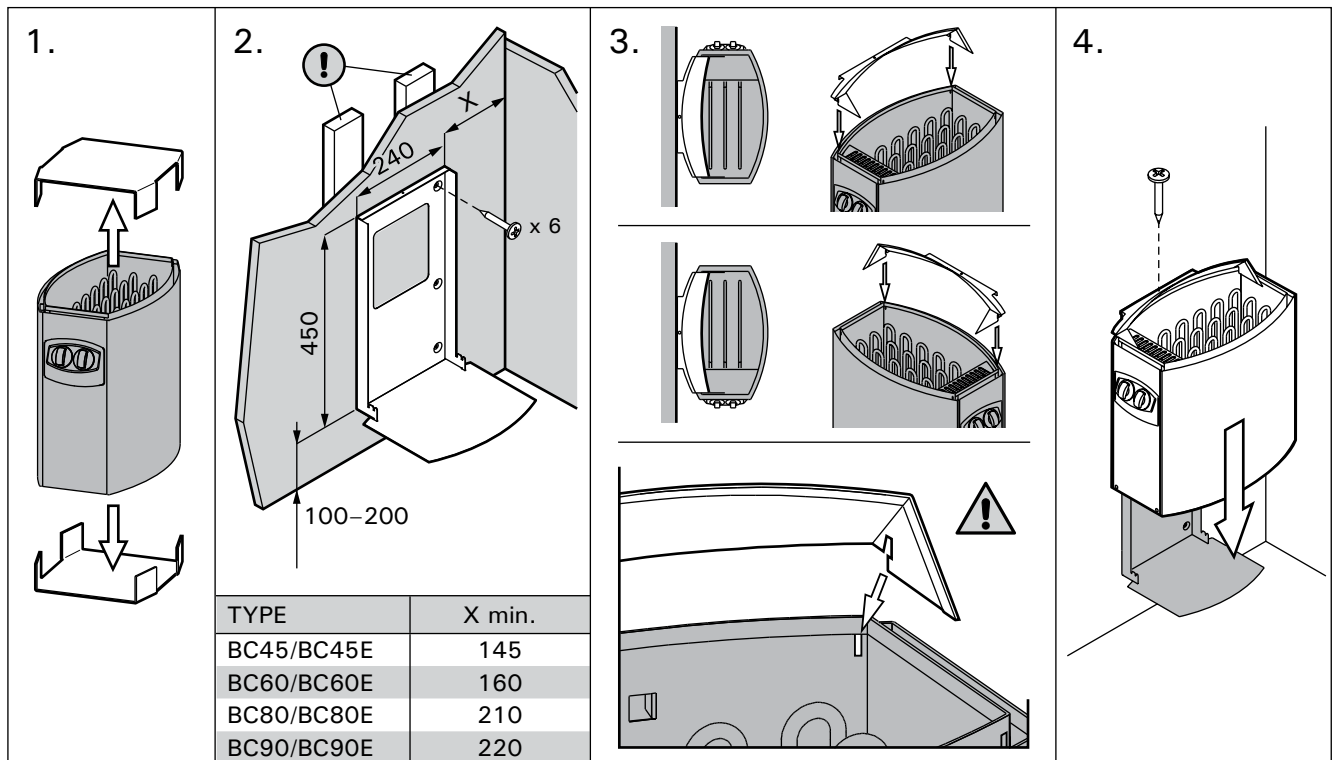

Figure 7. Fastening the heater on a wall (all dimensions in millimeters)
Фигура 7. Закрепване на нагревателя към стена (всички размери в милиметри)

3.3. Electrical Connections

The heater may only be connected to the electrical network in accordance with the current regulations by an authorised, professional electrician.

- The heater is semi-stationarily connected to the junction box (figure 8: A) on the sauna wall. The junction box must be splash-proof, and its maximum height from the floor must not exceed 500 mm.
- The connecting cable (figure 8: B) must be of rubber cable type H07RN-F or its equivalent. **NOTE! Due to thermal embrittlement, the use of PVC-insulated wire as the connecting cable of the heater is forbidden.**
- If the connecting and installation cables are higher than 1000 mm from the floor in the sauna or inside the sauna room walls, they must be able to endure a minimum temperature of 170 °C when loaded (for example, SSJ). Electrical equipment installed higher than 1000 mm from the sauna floor must be approved for use in a temperature of 125 °C (marking T125).
- In addition to supply connectors, the BC heaters are equipped with a connector (P), which makes the control of the electric heating possible (figure 10). Voltage control is transmitted from the heater when it is switched on. The control cable for electrical heating is brought directly into the junction box of the heater, and from there to the terminal block of the heater along a rubber cable with the same cross-section area as that of the connecting cable.
- **When closing the cover of the connection box make sure that the upper edge of the cover is placed correctly.** If the upper edge is misplaced water can enter the connection box. Figure 8.

3.3. Електрически връзки

Нагревателят може да бъде свързан към електрическата мрежа в съответствие с действащите разпоредби от оторизиран професионален електротехник.

- Нагревателят е полустационарно свързан към съединителната кутия (фигура 8: А) на стената на сауната. Разпределителната кутия трябва да е устойчива на пръски, а максималната ѝ височина от пода не трябва да надвишава 500 mm.
- Свързващият кабел (фигура 8: В) трябва да бъде от гумен кабел тип H07RN-F или негов еквивалент. **ЗАБЕЛЕЖКА! Поради термична крехкост, използването на проводник с PVC изолация като свързващ кабел на нагревателя е забранено.**
- Ако свързващите и инсталационните кабели са по-високи от 1000 mm от пода в сауната или вътре в стените на сауната, те трябва да могат да издържат на минимална температура от 170 °C, когато са натоварени (например SSJ). Електрическото оборудване, инсталирано на височина над 1000 mm от пода на сауната, трябва да бъде одобрено за употреба при температура от 125 °C (маркировка T125).
- В допълнение към конекторите за захранване, нагревателите BC са оборудвани с конектор (P), който прави възможно управлението на електрическото отопление (фигура 10). Контролът на напрежението се предава от нагревателя, когато е включен. Контролният кабел за електрическо отопление се извежда директно в разклонителната кутия на нагревателя, а оттам до клеморедата на нагревателя по гумен кабел със същото сечение като това на свързващия кабел.
- **Когато затваряте капака на съединителната кутия, уверете се, че горният ръб на капака е поставен правилно.** Ако горният ръб е поставен неправилно, водата може да влезе в кутията за свързване. Фигура 8.

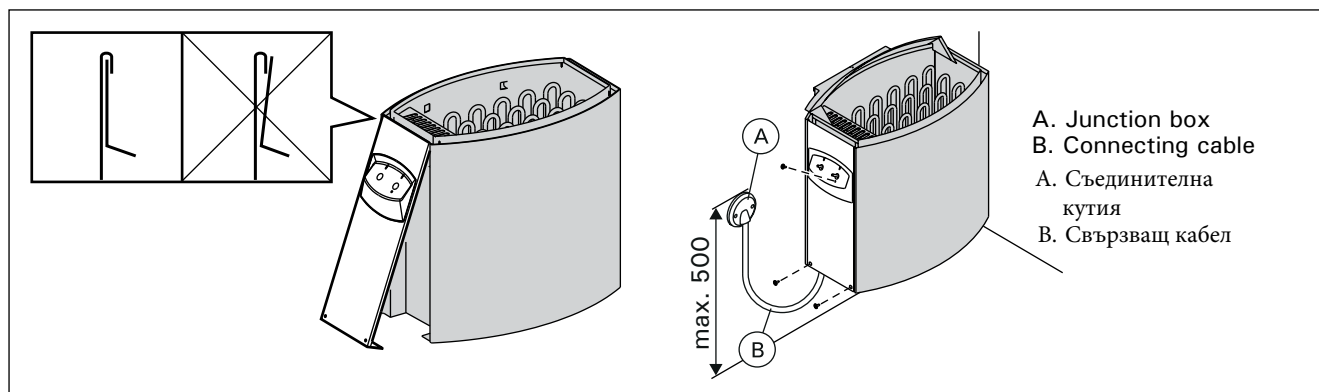

Figure 8. Closing the cover of the connection box (all dimensions in millimeters)
Фигура 8. Затваряне на капака на съединителната кутия (всички размери в милиметри)

3.3.1. Electric Heater Insulation Resistance

When performing the final inspection of the electrical installations, a "leakage" may be detected when measuring the heater's insulation resistance. The reason for this is that the insulating material of the heating elements has absorbed moisture from the air (storage, transport). After operating the heater for a few times, the moisture will be removed from the heating elements.

Do not connect the power feed for the heater through the RCD (residual current device)!

3.3.1. Съпротивление на изолацията на електрическия нагревател

При извършване на окончателната проверка на електрическите инсталации може да се открие „теч“ при измерване на съпротивлението на изолацията на нагревателя. Причината за това е, че изолационният материал на нагревателните елементи е абсорбирал влага от въздуха (съхранение, транспорт). След като включите нагревателя няколко пъти, влагата ще бъде отстранена от нагревателните елементи.

Не свързвайте захранването на нагревателя през RCD (устройство за остатъчен ток)!

3.4. Installation of the Control Unit and Sensors (BC-E)

The control unit includes detailed instructions for fastening the unit on the wall. Install the temperature sensor on the wall of the sauna room above the heater. It should be installed on the lateral centre line of the heater, 100 mm downwards from the ceiling. Figure 6.

Do not place the supply air vent so that the air flow cools the temperature sensor. Figure 5.

3.5. Resetting the Overheat Protector

If the temperature of the sauna room becomes dangerously high, the overheat protector will permanently cut off the supply of the heater. The overheat protector can be reset after the heater has cooled down.

BC

The reset button is located inside the heater's connection box (figure 9). **Only persons authorised to carry out electrical installations can reset the overheat protector.**

Prior to pressing the button, the cause of the fault must be found.

- Are the stones crumbled and pressed together?
- Has the heater been on for a long time while unused?
- Is the sensor of the thermostat out of place or broken?
- Has the heater been banged or shaken?

BC-E

See the installation instructions for control unit.

3.4. Монтаж на контролния блок и сензори (BC-E)

Блокът за управление включва подробни инструкции за закрепване на модула към стената. Монтирайте температурния сензор на стената на сауната над печката. Той трябва да се монтира на страничната централна линия на нагревателя, 100 mm надолу от тавана. Фигура 6.

Не поставяйте вентилационния отвор за подаване на въздух така, че въздушният поток да охлажда температурния сензор. Фигура 5.

3.5. Нулиране на защитата от прегряване

Ако температурата в сауната стане опасно висока, защитата от прегряване ще прекъсне завинаги захранването на нагревателя. Защитата от прегряване може да се нулира, след като нагревателят се охлади.

пр.н.е

Бутонът за нулиране се намира вътре в кутията за свързване на нагревателя (фигура 9). Само лица, упълномощени да извършват електрически инсталации, могат да нулират защитата от прегряване.

Преди да натиснете бутона, трябва да откриете причината за повредата.

- Камъните натрошени и притиснати ли са?
- Нагревателят включен ли е дълго време, без да е използван?
- Сензорът на термостата не е на място или е счупен?
- Нагревателят бил ли е удрян или разклатен?

BC-E

Вижте инструкциите за монтаж на контролния блок.

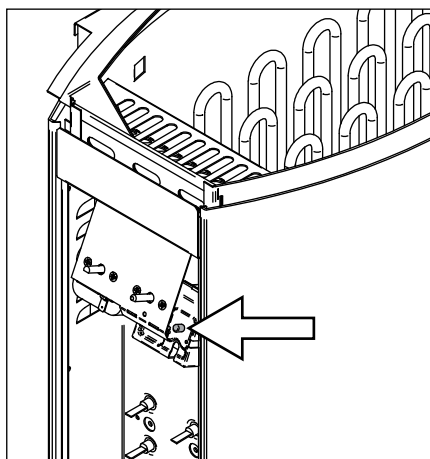

Figure 9. Reset button for overheat protector
Фигура 9. Бутон за нулиране за защита от прегряване

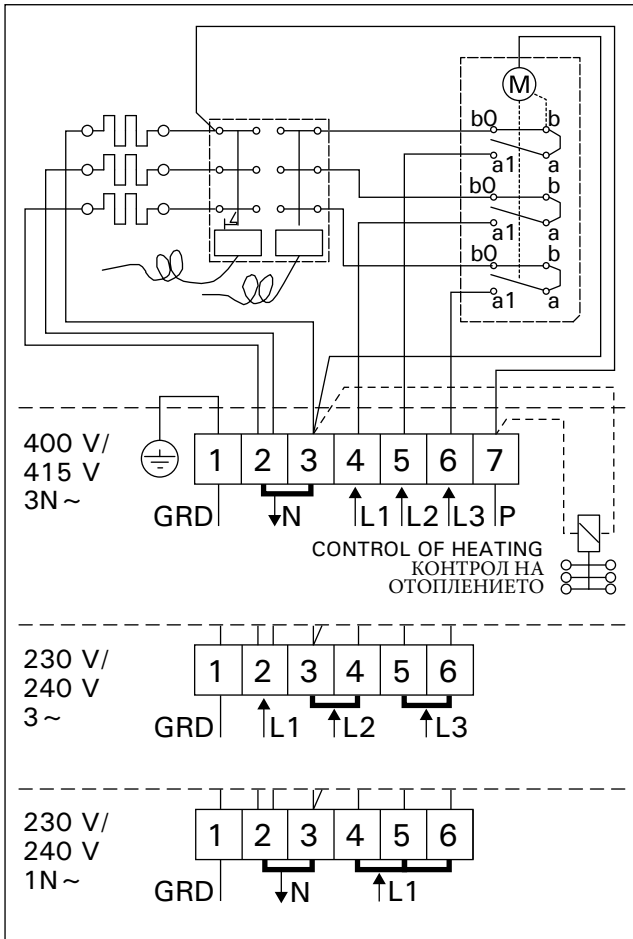

Figure 10. Electrical connections of BC heater
 Фигура 10. Електрически връзки на BC нагревател

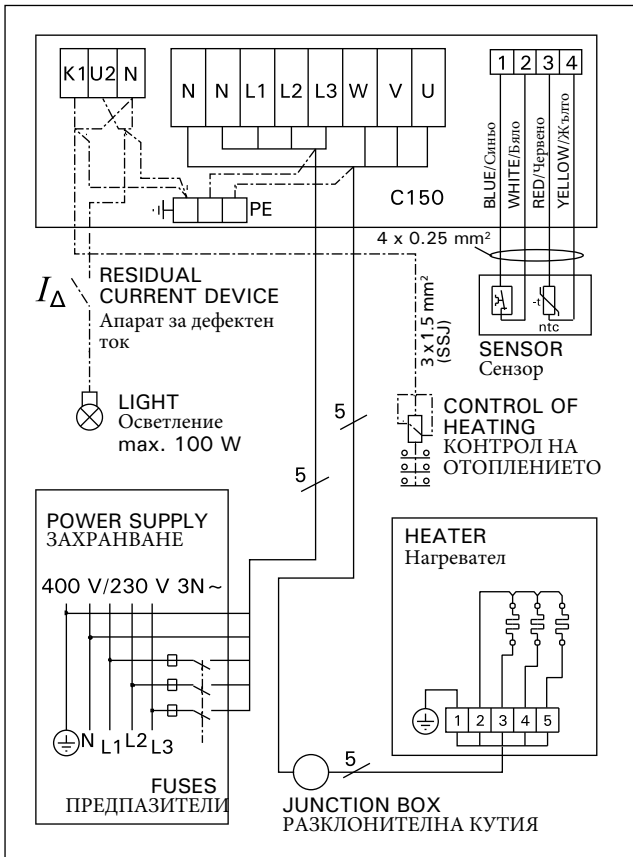

Figure 12a. 3-phase electrical connections of control unit C150 and BC-E heater
 Фигура 12a. 3-фазни електрически връзки на контролен блок C150 и нагревател BC-E

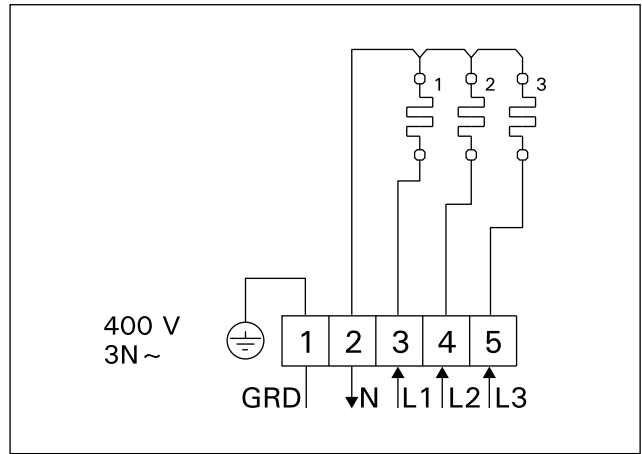

Figure 11. Electrical connections of BC-E heater
 Фигура 11. Електрически връзки на нагревател BC-E

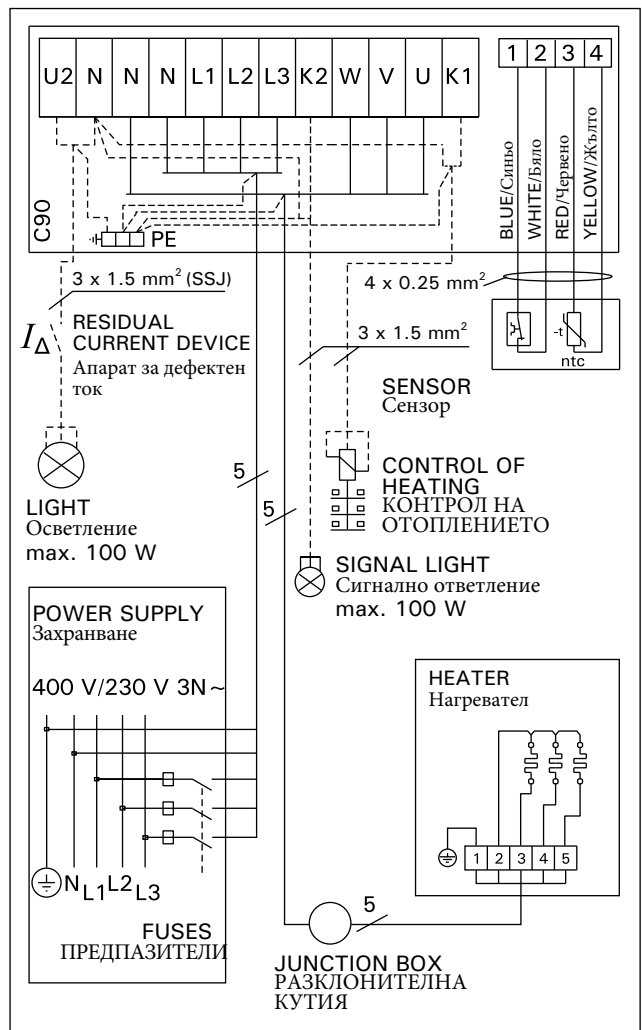

Figure 12b. 3-phase electrical connections of control unit C90 and BC-E heater
 Фигура 12b. 3-фазни електрически връзки на контролен блок C90 и нагревател BC-E

4. VARAOSAT

4. SPARE PARTS

4. ЗАПАСНЫЕ ЧАСТИ

4. REZERVES DAĻAS

4. PIÈCES DÉTACHÉES

4. CZĘŚCI ZAMIENNE

4. RESERVDELAR

4. РЕЗЕРВНИ ЧАСТИ

4. VARUOSAD

4. ATSARGINĒS DETALĒS

4. RESERVEONDERDELEN

4. NÁHRADNÍ DÍLY

1	ZSB-224	1500 W/230 V
2	ZSB-226	2000 W/230 V
3	ZSB-228	2670 W/230 V
4	ZSB-229	3000 W/230 V
5	ZSK-510	⌚ (BC)
6	ZSB-125	
7	ZSK-520	°C (BC)
8	ZSB-115	

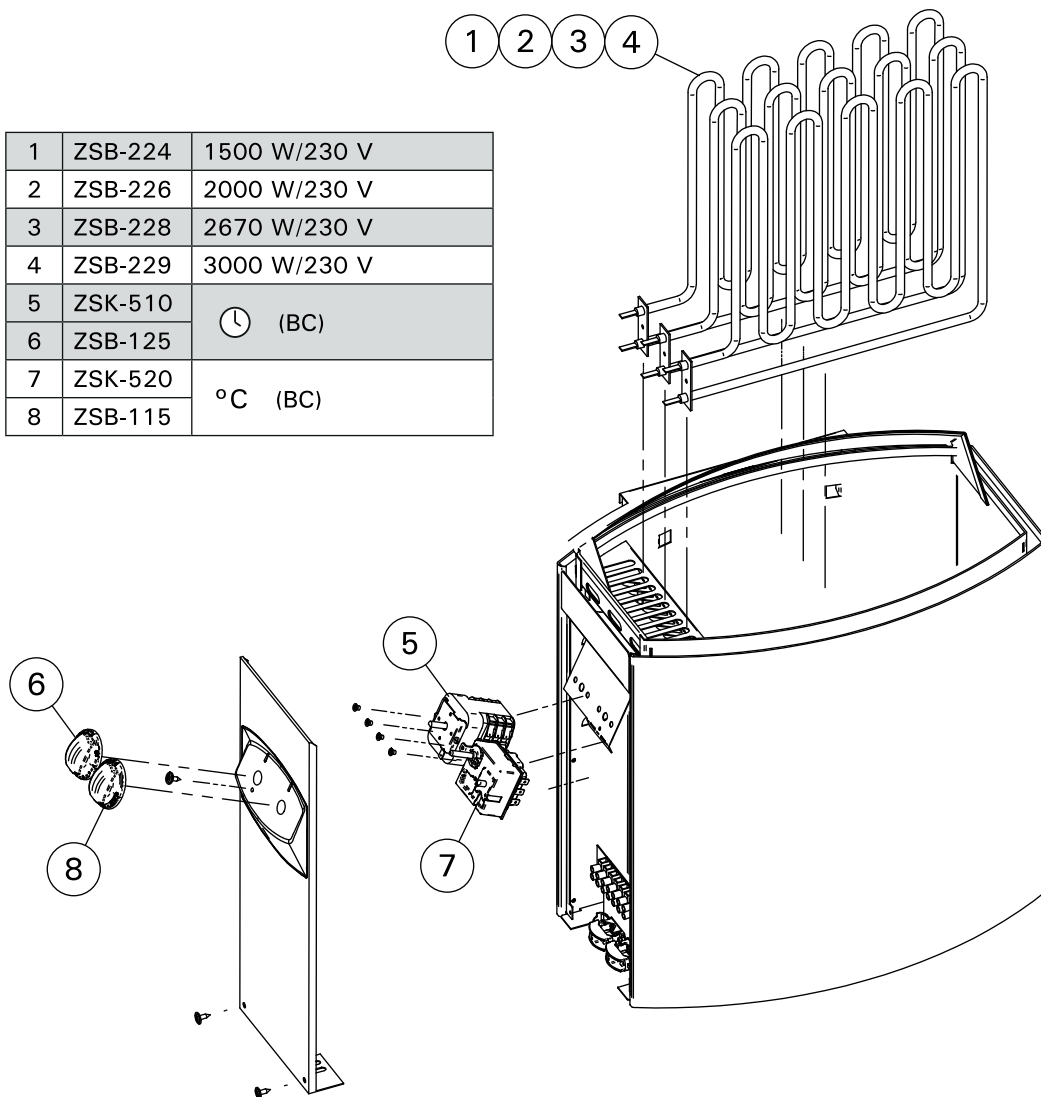

HARVIA

Harvia Oy
PL12
40951 Muurame
Finland
www.harvia.fi

K10180

Kültéri finn szauna

Szerelési és kezelési útmutató

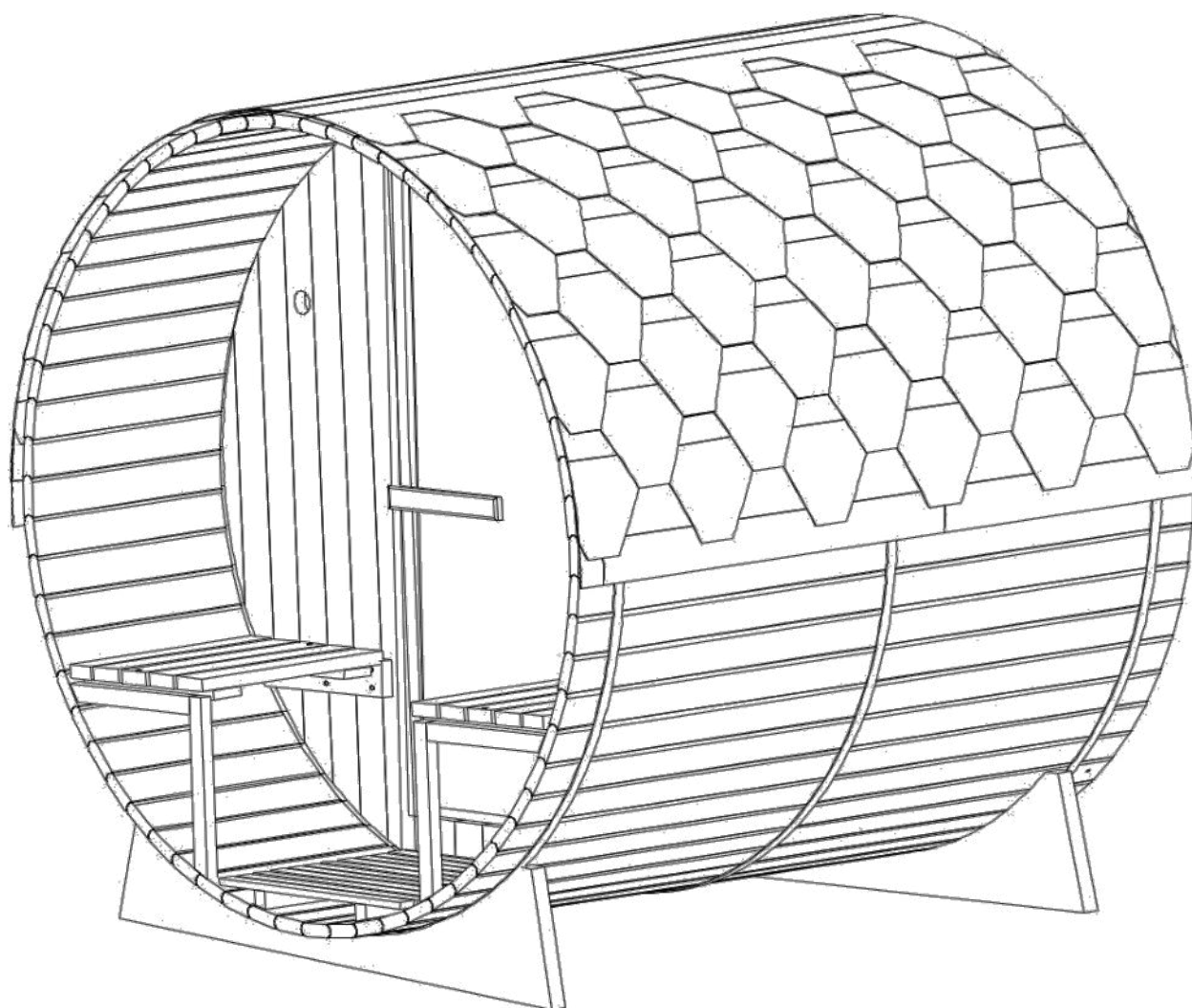

Előszó

Köszönjük, hogy a SANOTECHNIK termékét választotta. Kérjük, összeszerelés előtt figyelmesen olvassa el ezt a kézikönyvet és őrizze is meg. Kérjük, jegyezze fel a sorozatszámokat, mivel erre egy esetleges javítás vagy cserealkatrészek rendelése során szüksége lesz. Csak eredeti alkatrészeket használjon!

FIGYELEM!

Az elektromos bekötést és javítást csak szakképzett villanyszerelő végezheti! A beüzemelés előtt ellenőrizze a hálózati feszültséget és győződjön meg arról, hogy a földelt aljzatot megfelelően kötötte be.

A szaunához használt konnektorba ne dugjon más berendezéseket.

A szaunát vízszintes és stabil felületre kell elhelyezni, amely elbírja a szauna súlyát.

SZERELÉSI ÚTMUTATÓ

Szerelési tippek

Kérjük, hogy a termék kicsomagolása után, de még az összeszerelés előtt ellenőrizze, hogy minden rész és alkatrész hiánytalanul és sértetlenül rendelkezésre áll. A szauna összeszereléséhez legalább 3 személyre van szükség. Kérjük, ellenőrizze a furatok átmérőjét, hogy elkerülje a fa sérülését.

Eszközök



Csavarhúzó



Mérőszalag



Ceruza



Csavakulcs



Fúrósár



Imbuszkulcs



Kalapács



Tapétavágó









Létra

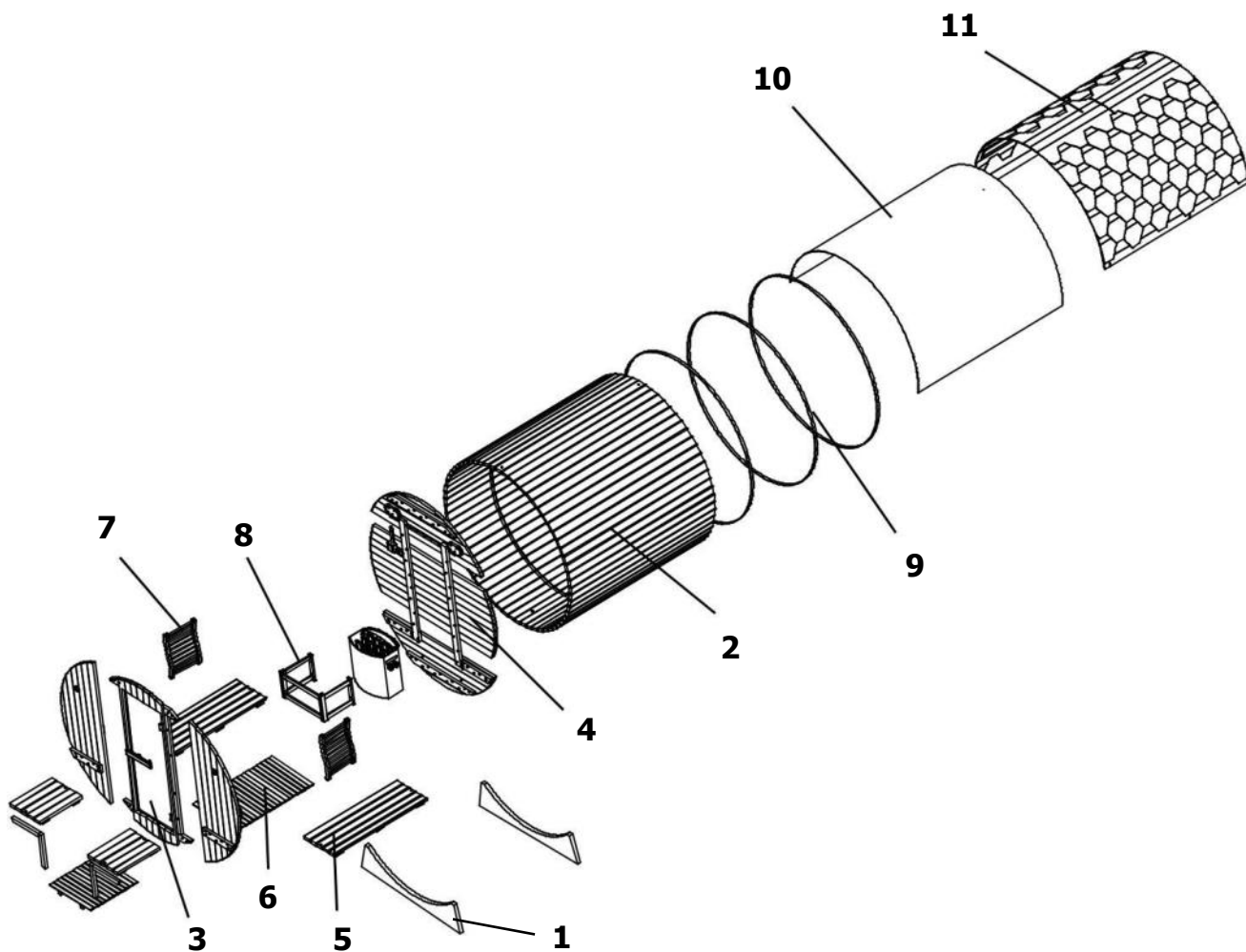

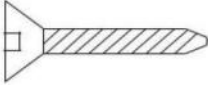





















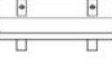
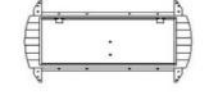
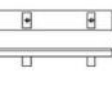







Akkus fúrógép

A szauna részei

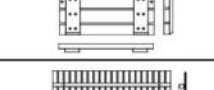

						
Ø5x50	Ø4x50	Ø4x30	Ø3x35	Ø4x12	Ø6x70	
44x	20x	8x	66x	240x	2x	2x

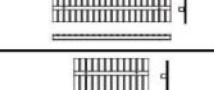
A szauna részei

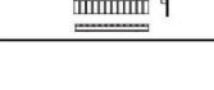
1		2x	1400x300x33 mm	7		2x	520x330x65 mm
2.1		2x	1800x93x30 mm	8.1		1x	560x300x40 mm
2.2		1x	1800x93x30 mm	8.2		2x	378x300x40 mm
2.3		60x	1800x93x30 mm	9		3x	acél pánt
2.4		1x	1800x93x30 mm	10		1x	3000x1800 mm
3.1		1x	1758x575x30 mm	11		60x	1000x320 mm
3.2		1x	1650x575x30 mm	12		1x	250x50x45 mm
3.3		1x	1758x952x30 mm	13		1x	350x50x45 mm
4.1		1x	1404x80x20 mm	14		1x	szaunakályha
4.2		1x	1404x80x20 mm	15		1x	177x80x30 mm
4.3		1x	1574x488x30 mm	16		1x	vizes tálca
4.4		1x	1758x783x30 mm	17		2x	lámpa
4.5		1x	1574x488x30 mm	18		2x	pohártartó
5.1		2x	1152x425x50 mm	19		1x	szaunadézsza
5.2		2x	426x398x30 mm	20		1x	hő- és páramérő
5.3		2x	532x425x50 mm	21		1x	homokóra
6.1		1x	990x585x40 mm	22		1x	felöntő kanál
6.2		1x	535x585x40 mm				

Az összeszerelés lépései

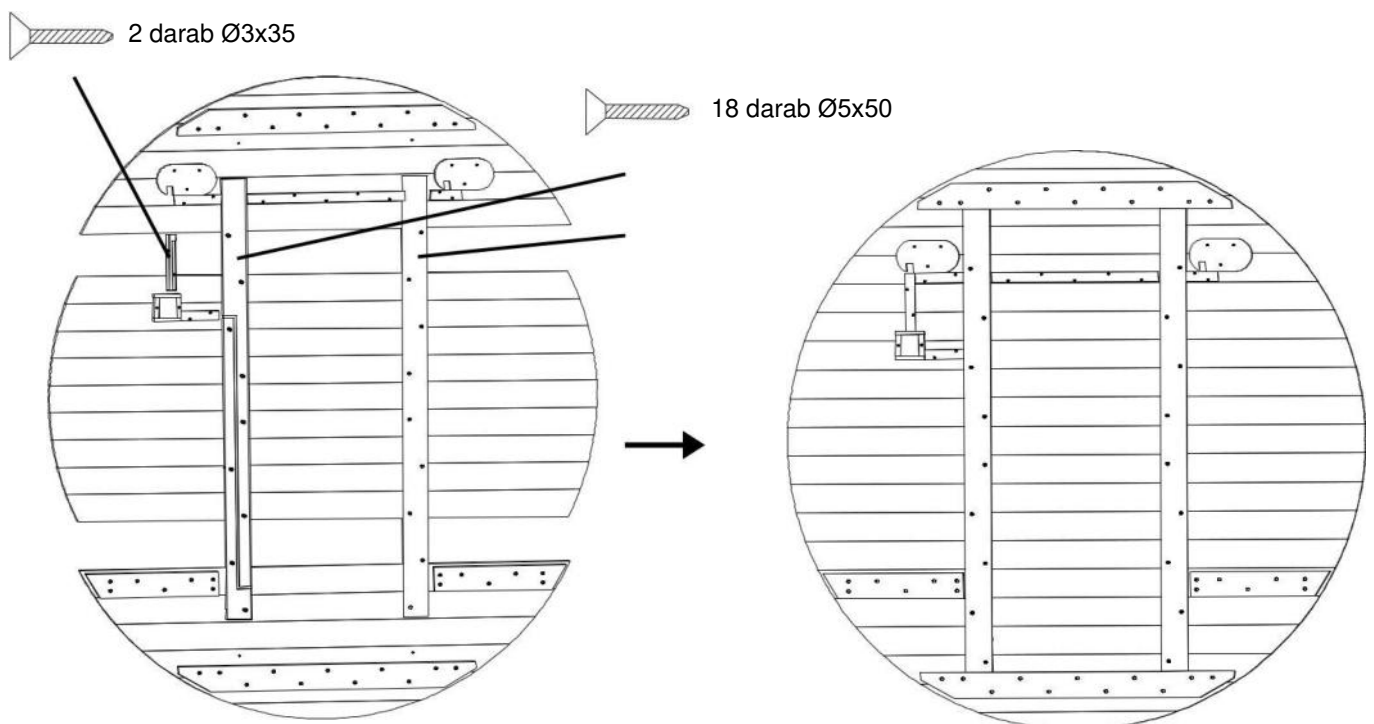
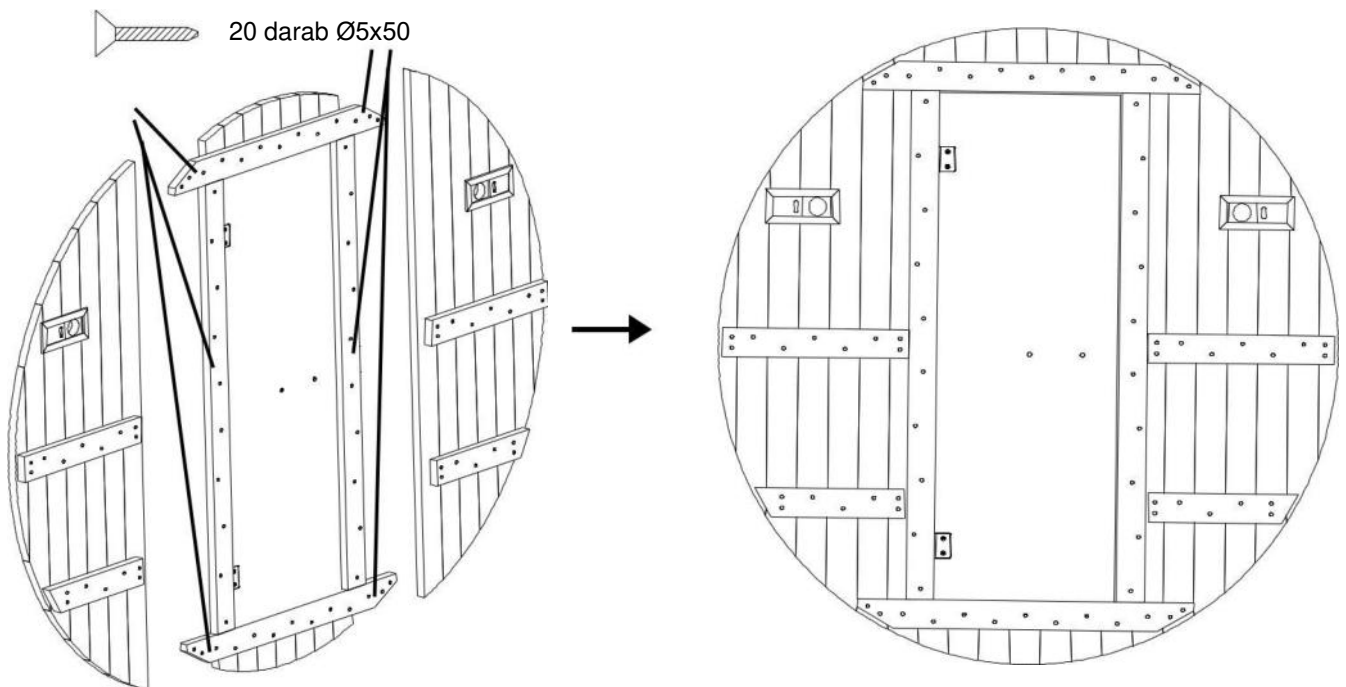

Első lépésként szerelje össze a hordó elülső és hátsó falát. Mindkét fal 3 elemből áll. Az elülső fal egy bal oldali, egy középső és egy jobb oldali, míg a hátsó fal egy alsó, egy középső és egy felső elemből áll.

Az összeszerelés lépései

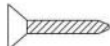
 2 darab Ø5x50

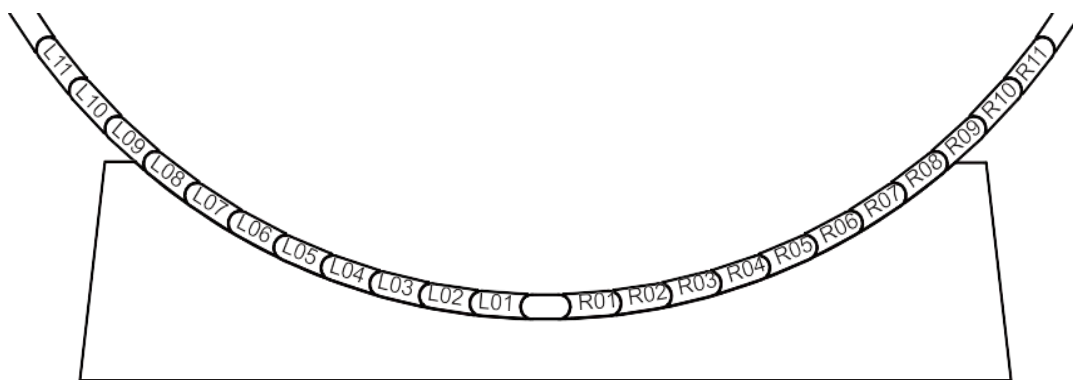
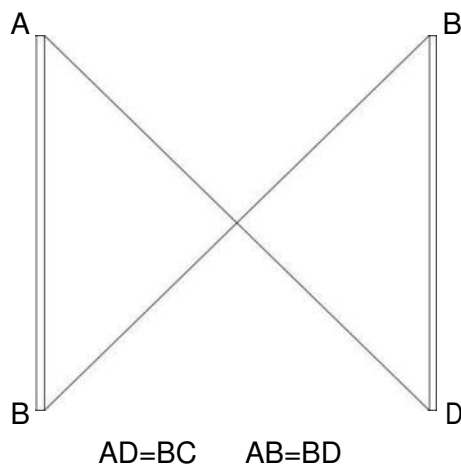
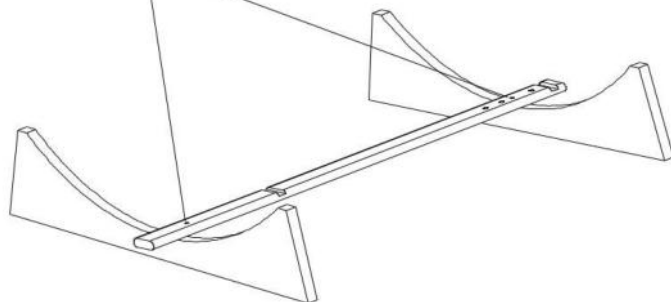

Minden dongát elláttunk egy számozott etikettel:

- bal oldalon: L01 - L38 letről felfelé
- jobb oldalon: R01 - R38 letről felfelé

Az összeszerelés lépései

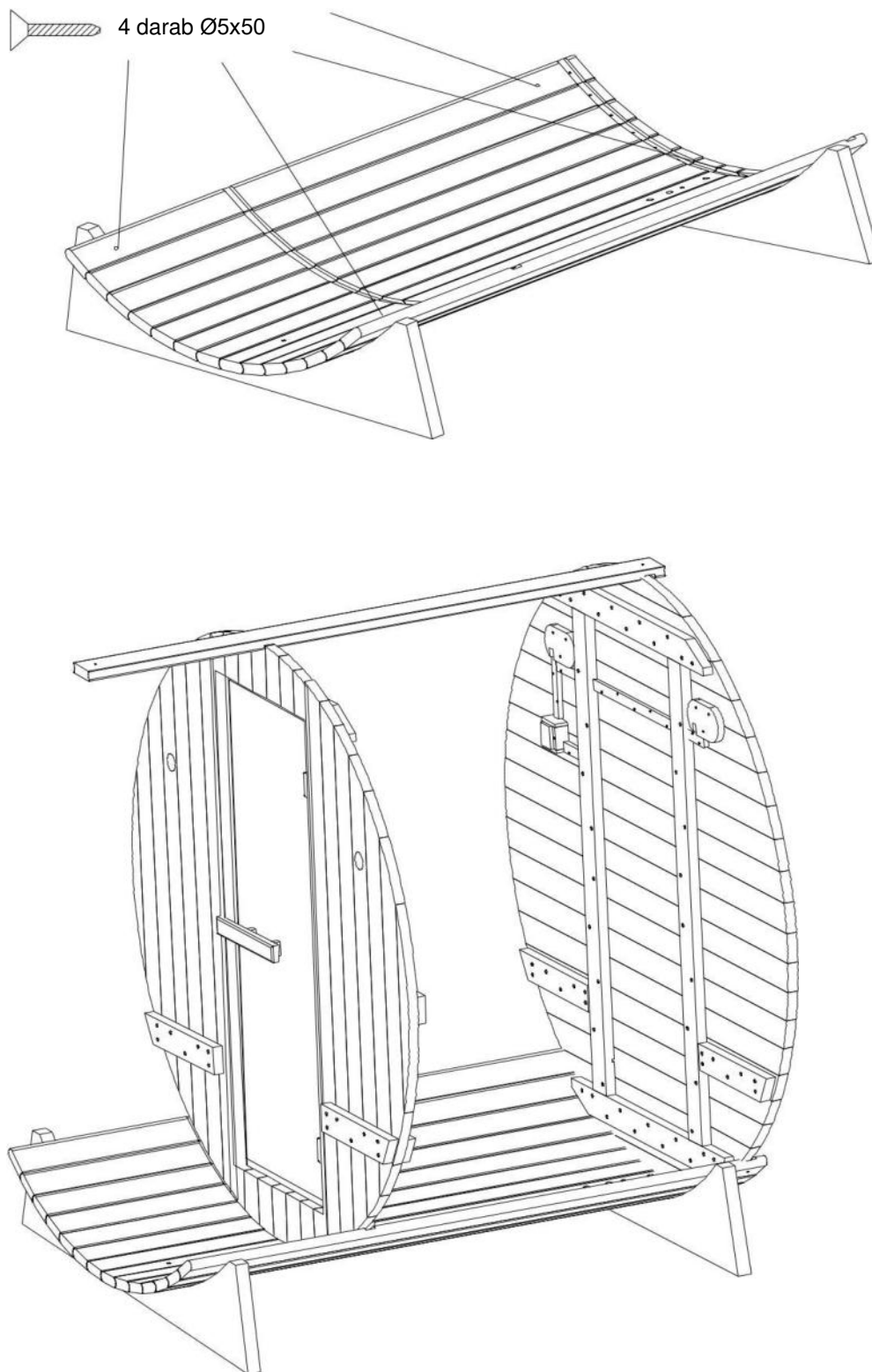

Ideiglenesen szerelje fel a felső dongát, így az a szerelés ideje alatt támasztéku szolgál.

Az összeszerelés lépései

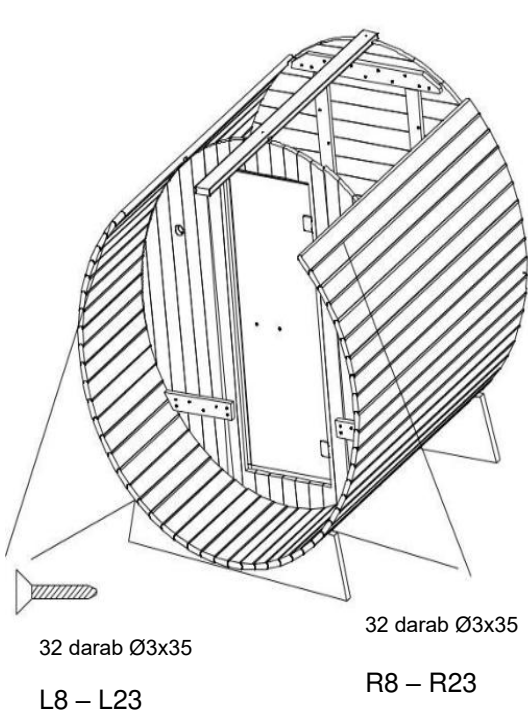

32 darab Ø3x35
R8 - R23

1. A dongákat szorosan egymás mellé csavarozza, hogy biztosítsa a szigetelést és a felső dongáknak is elegendő helye legyen.
2. Miután felcsavarozta az L8 - L23 és R8 - R23 dongákat, tegye helyükre a felső dongákat, hogy azok egy szabályos hengert formázzanak.

Ha szükséges, a csavarok meglazítása után középen egy vagy két vékony lécezt eltávolíthat.

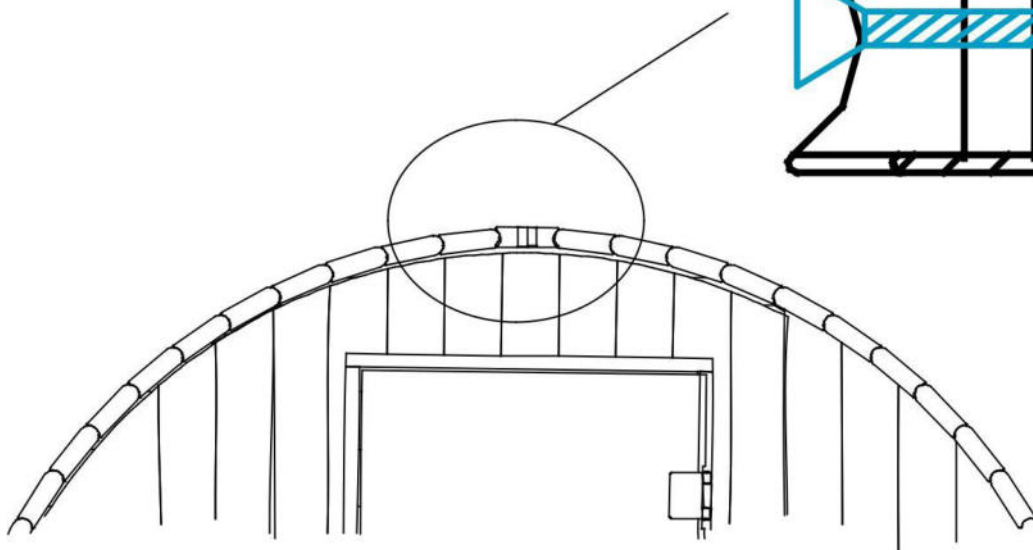
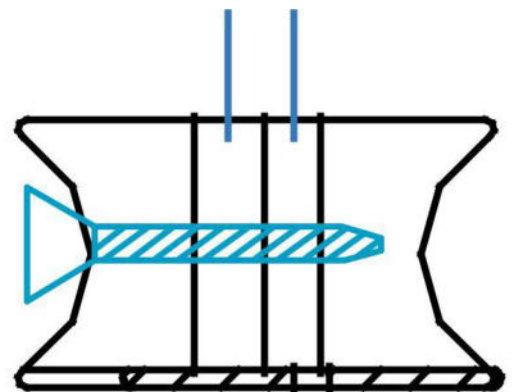

Az összeszerelés lépései

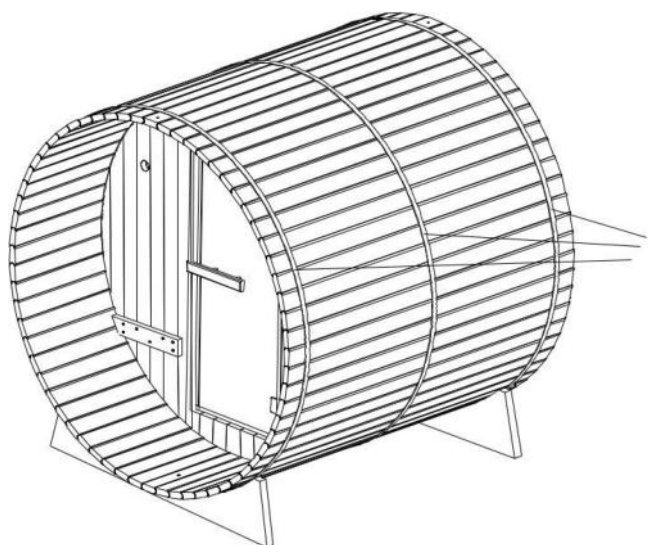

Rozsdamentes acél pántok

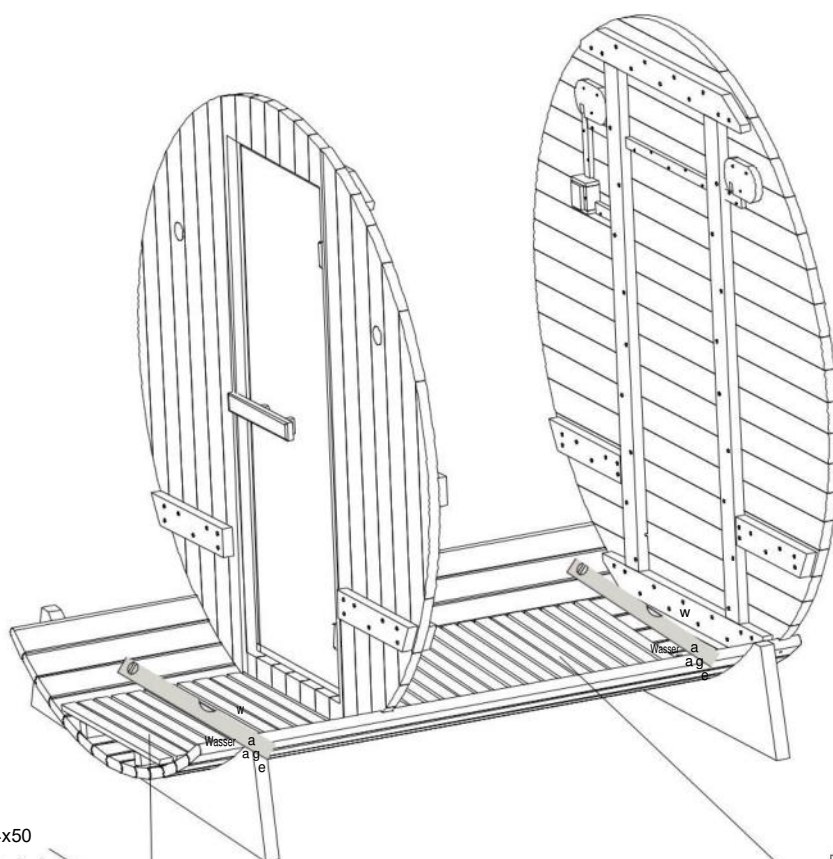

4 darab Ø4x50



4 darab Ø4x50

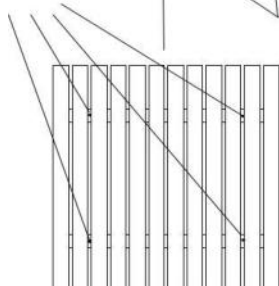

Padlólapok

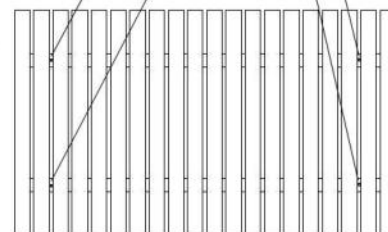

Az összeszerelés lépései

Az ülékek tartóelemét előszereltük.
Az ülékeket csavarozza a tartóelemekhez.
A külső ülékek rögzítése előtt szerelje fel a lábakat!

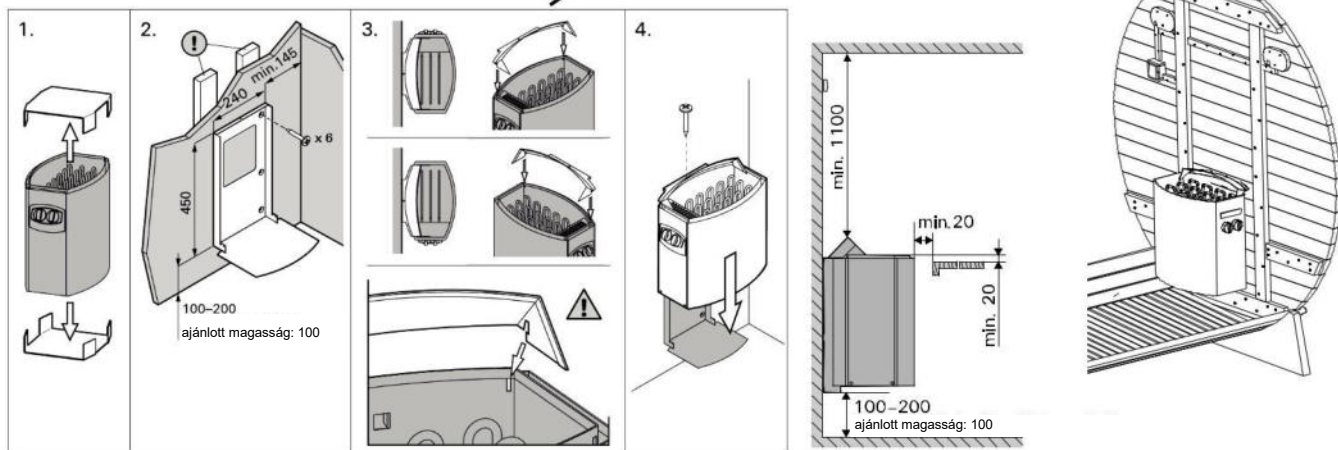
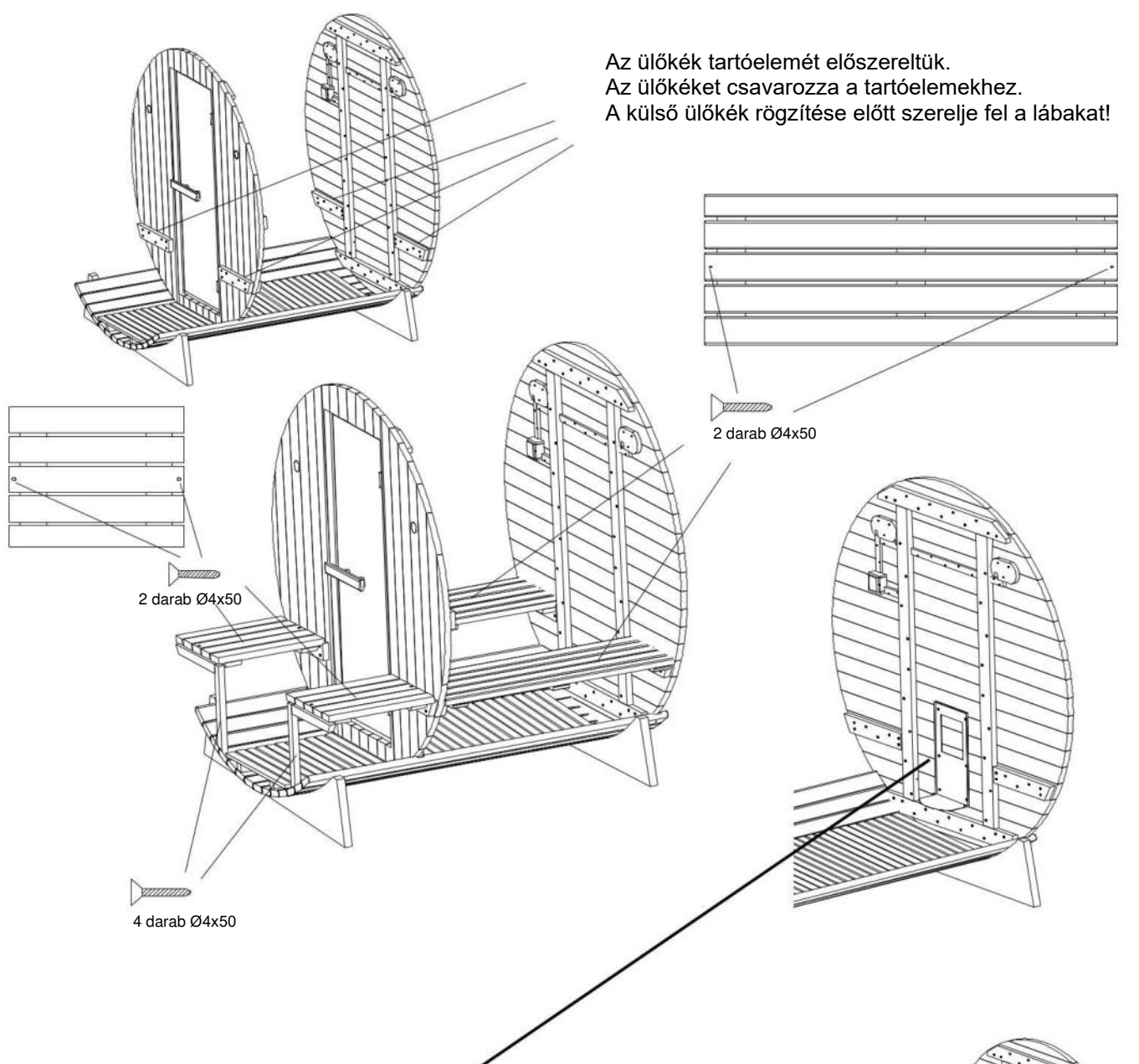

Szerelje fel a szaunakályha fali tartó elemét, majd akassza fel a szaunát.
Kérjük, figyelmesen olvassa el a szaunakályha útmutatóját!

A világítás a szaunakályhán keresztül kap áramot.

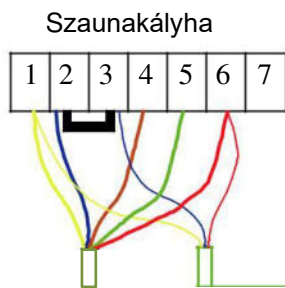
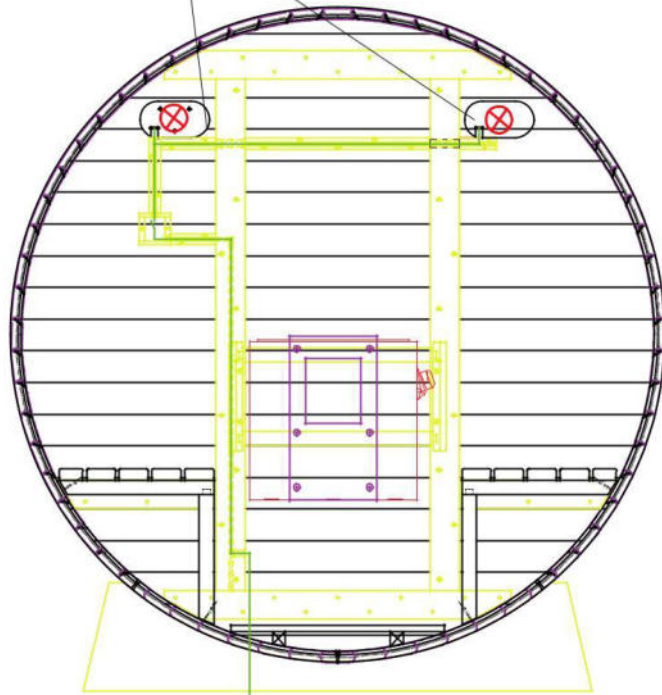
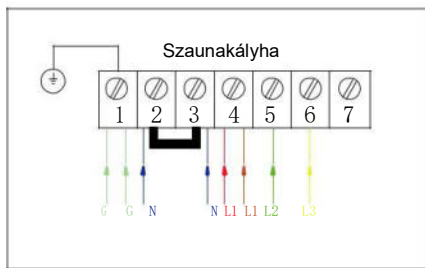
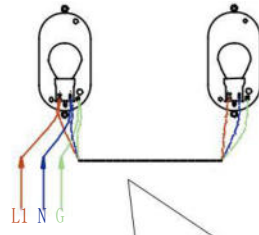

Vezérlőkábel (5*2,5mm²)

Világítás kábele (3*0,75mm²)

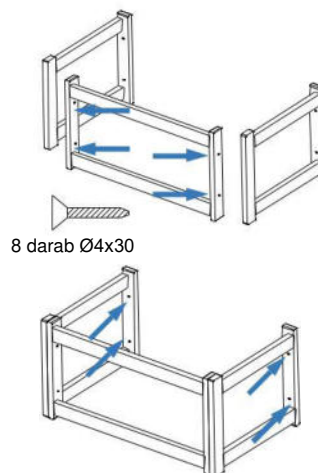
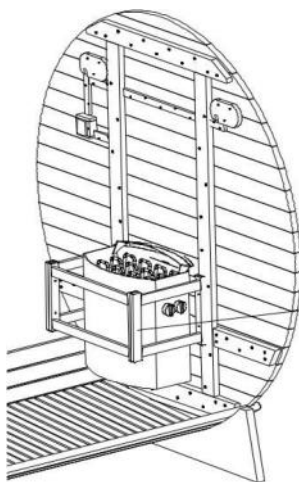

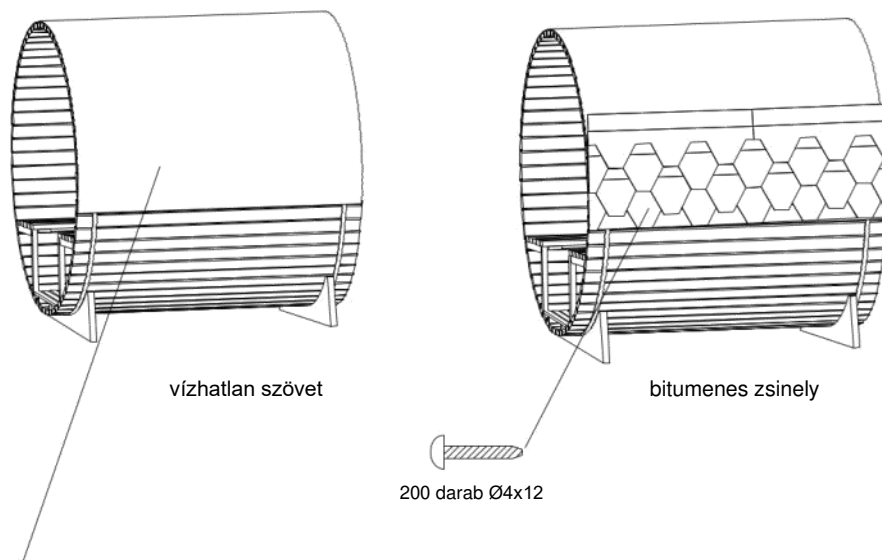

vízhatlan szövet

bitumenes zsinegy

200 darab Ø4x12

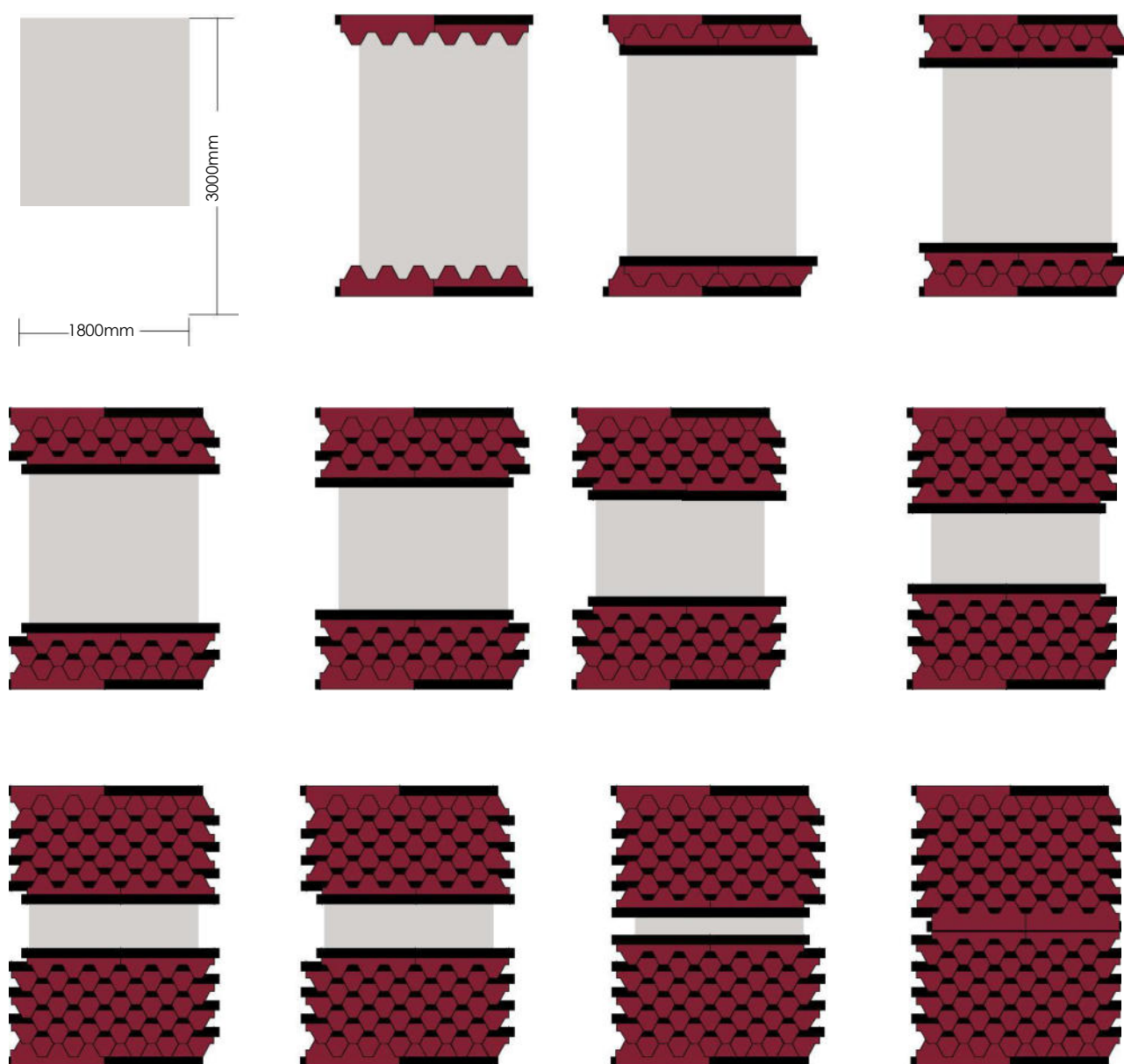
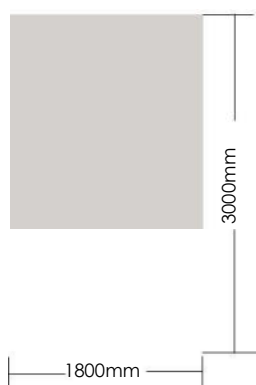

A szaunakályha működése

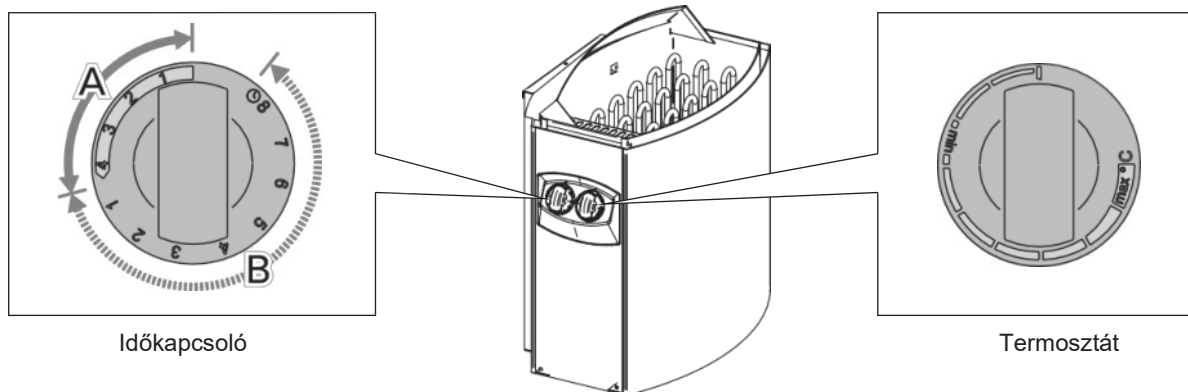

1. Azonnali fűtés

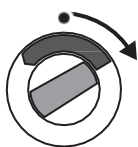

Ha az időkapcsolót a fenti ábrán A-val jelzett szakaszon belül forgatja el, a kályha azonnal fűteni kezd.

(A fűtés időtartama: 0-4 óra)

2. Előprogramozás



Ha az időkapcsolót a fenti ábrán B-vel jelzett szakaszon belül forgatja el, beállíthatja, hogy a kályha hány óra múlva kezdjen el fűteni. A felfűtés akkor kezdődik, ha a kapcsoló alapállásba kerül.

Időtartam: 0-8 óra

A fűtés ezt követően 4 órán át működik.

További információt a szaunakályha útmutatójában talál.

Hibaelhárítás

FONTOS!

Minden beavatkozás előtt áramtalanítsa a szaunát!

Az elektromos részek javítását vagy cseréjét bízza szakemberre!

Hibajelenség	A hiba lehetséges oka	Hibaelhárítás
A szaunakályha nem fűt fel.	Nem csatlakoztatta a vezérlőkábelt.	Ellenőrizze a csatlakozást.
	Nem biztosított az áramellátás.	Ellenőrizze, hogy a kapcsolótábla vagy a csatlakozóaljzat nem hibásodott-e meg.
	Bekapcsolt a szaunakályha túlmelegedés elleni védelem.	Olvassa el a szaunakályha útmutatóját!
Nem működik a világítás.	Nem csatlakoztatta a világítás kábelét.	Ellenőrizze a csatlakozást.
	Kiégett az izzó.	Cserélje ki az izzót.

Tisztítás, karbantartás

A szaunahordó külsejét az összeszerelést követően egy kefével tisztítsa meg.

A külső felületet az állagmegőrzés érdekében és hogy védje azt az időjárási viszontagságoktól (csapadék, napsugárzás), faolajjal kezelje le.

A felújító kezelést évente ajánlott elvégezni.

Egészség- és környezetvédelmi szempontból nem javasoljuk erős kémiai szerek (lazúr, fazománc) használatát.

A szauna belsejét nedves pamutkendővel tisztítsa meg, majd tiszta, száraz ruhával törölje szárazra.

A résekből a port legegyszerűbben porszívóval távolíthatja el.

Ne használjon kémiai tisztítószereket!

Az üvegeket ablaktisztítóval és puha ruhával tisztítsa meg.

Használati és biztonsági útmutató

Kérjük, hogy használat előtt olvassa át az alábbi útmutatót.

Ha kétségei merülnek fel, hogy használhatja-e a szaunát, kérje ki kezelőorvosa véleményét.

Ha szaunázás közben szédülést vagy hőhullámokat tapasztal, azonnal hagyja el a szaunát!!

Kisgyermekeket és háziállatokat ne engedjen a szaunába!

Az elektromos részeket nem érheti víz! Ügyeljen rá, hogy a szaunakályhára ne fröcsögjön víz vagy veríték, mert ez rövidzárlatot okozhat.

A szaunakályhát soha ne takarja le, mert tűzveszélyes. Mindig tartsa távol a kályhától a gyúlékony anyagokat (pl. törölközőket).

Ha tűz ütne ki a szaunában, megfékezésére soha ne használja ruháit vagy törölközőit.

Ne érintse meg a kályhát a használat során és röviddel utána, mivel a forró részek miatt fennáll az égési sérülések veszélye.

Amennyiben nem használja a készüléket, figyeljen rá, hogy mindig kapcsolja ki.

3 óránál hosszabb ideig ne hagyja bekapcsolva a szaunakályhát. 3 óra használat után legalább egy óra hosszára kapcsolja ki a készüléket.

Bekapcsolt állapotban ne hagyja felügyelet nélkül a készüléket!

Az áramütések elkerülése érdekében viharban ne használja a szaunát!

Ne szereljen zárat a szauna ajtajára, nehogy valaki a szaunában rekedjen!

A finn szauna jótékony élettani hatásai

- a forró és száraz levegőn elpusztulnak a baktériumok, vírusok
- a verejtékezéssel a bőrön keresztül távoznak a szervezetből a méreg- és salakanyagok
- javítja a vérkeringést, erősíti a szívet
- növeli a szervezet ellenálló képességét
- rugalmassá teszi a bőrt
- enyhíti az izomlázat
- stresszoldó hatása van

Szaunázás közben fokozódik a vérkeringés, ezáltal a szervezet több oxigénhez jut, így könnyebben ellazul, regenerálódik. Már havi egyszeri szaunázás is pozitív hatással bír.

Néhány jótanács

Ha a szauna használata előtt meleg vagy forró zuhanyt vesz, még intenzívebbé teheti a verítékezést. Tusolás után alaposan törölközzön meg. Egyrészt a száraz bőr jobban verítékezik, másrészt a víz károsítja a kabin faanyagát.

A szaunázáshoz minimum 3 törölközőt használjon. Egyet terítsen a padlóra, a lába alá, egyet a padra, amire ráül, a harmadikkal pedig rendszeresen itassa fel testéről az izzadságot.

Szaunázás előtt mindig vegye le az ékszereit, mert a nagy melegben azok gyorsan felforrósodnak és megégethetik bőrét.

Se éhesen, se tele gyomorral ne használja a szaunát. Szaunázás előtt csak mértékkel vegyen magához folyadékot, szaunázás után viszont fogyasszon legalább egy liter vizet.

Megerőltető fizikai igénybevétel (sport, munka) után ne használja a kabint. Várjon legalább 30 percet, amíg szervezete pihen. A szaunázás akkor a leghatásosabb, ha ruha nélkül teszi. A fürdőruhával betakart testfelület alatt a bőr nem tud lélegezni, így a méregtelenítő folyamatok nem működnek megfelelően.

A szaunázás javasolt időtartama: 8-12 (kezdőként 4-8) perc, amelyet kövessen egy 5-10 perces hűlési fázis hideg vizes zuhanyzással.

MIKOR NE SZAUNÁZZON?

A szauna kiváló a betegségek kialakulásának megelőzésére, azonban ha már lázas beteg, akkor tilos szaunázni!

Ellenjavallt a szauna használata:

- idős, legyengült személyeknek
- krónikus betegségben (diabétesz, epilepszia) szenvedőknek
- várandós anyáknak
- 12 év alatti gyermekeknek
- túlsúlyos, szívbeteg, magas vérnyomással vagy keringési és visszérproblémákkal küzdő személyeknek
- ha Ön rosszul tűri a meleget

Soha ne használja a szaunát, ha gyógyszert vett be, alkoholt vagy kábítószerrel fogyasztott, mert ezek használata a szaunában eszméletvesztéshez vezethet.

**BC45, BC60, BC80
BC45E, BC60E, BC80E, BC90E**

Elektromos szaunakályha beépítési és használati útmutató



BC



BC-E

Az alábbi beépítési és használati útmutató a szauna tulajdonosa vagy az azért felelős személy, illetve a kályha elektromos beépítéséért felelős villanyszerelő számára készült. A beépítést követően a beépítésért felelős személy adja át ezen útmutatót a szauna tulajdonosának vagy az üzemeltetésért felelős személynek. A kályha használata előtt kérjük, gondosan olvassa át az alábbi útmutatót.

A kályhát a szaunakabin szaunázáshoz megfelelő hőmérsékletre történő felmelegítésére tervezték, más egyéb célra nem használható. A CE jelzéssel ellátott szaunakályhák a szaunabeépítésre vonatkozó összes előírásnak megfelelnek. Az előírások betartását a megfelelő hatóságok ellenőrzik.

Gratulálunk választásához!

Garancia:

A családi szaunákban használt kályhákra és vezérlő berendezésekre vonatkozó garancia időszak két (2) év. A közösségi szaunákban alkalmazott kályhákra és vezérlő berendezésekre vonatkozó garancia időszak egy (1) év, a kályhák fűtőelemeire 6 hónap. A garancia nem vonatkozik a beépítésre, használatra vagy karbantartásra vonatkozó utasítások be nem tartásából eredő hibákra.

A garancia nem vonatkozik a nem a kályha gyártója által ajánlott kövek használatából eredő hibákra.

TARTALOM:

1. HASZNÁLATI ÚTMUTATÓ	4
1.1 A szaunakövek felrakása.....	4
1.1.1 Karbantartás	4
1.2. A szauna fűtése	5
1.3. A kályha használata	5
1.3.1. A kályha bekapcsolása.....	5
1.3.2. Időzítés (időzített bekapcsolás).....	5
1.3.3. A kályha kikapcsolása.....	6
1.3.4. A hőmérséklet beállítása	6
1.4. Víz felöntése a felhevült kövekre.....	6
1.5. Szaunázási útmutató.....	7
1.6. Figyelmeztetések	7
1.7. Hibaelhárítás.....	7
2. SZAUNAKABIN.....	9
2.1. A szaunakabin felépítése.....	9
2.1.1. A szaunafalak elfeketedése	10
2.2. A szaunakabin szellőzése	10
2.3. A kályha teljesítménye	10
2.4. A szaunakabin higiénája	11
3. BEÉPÍTÉSI ÚTMUTATÓ.....	11
3.1. Beépítés előtt.....	11
3.2. A kályha falra történő rögzítése	12
3.3. Elektromos csatlakozások	13
3.3.1. Az elektromos kályha szigetelési ellenállása	14
3.4. A vezérlőegység és az érzékelők beszerelése (BC-E)	14
3.5. A túlmelegedés elleni védelem visszaállítása	14
4. PÓTALKATRÉSZEK	19

1. HASZNÁLATI ÚTMUTATÓ

1.1 A szaunakövek felrakása

A szaunakövek felrakása nagymértékben befolyásolja a kályha működését (1. ábra).

A szaunakövekre vonatkozó fontos információk:

- A kövek átmérője 5-10 cm közötti legyen.
- Kizárólag szögletes, hasított felületű, kályhában történő használatra készült szaunaköveket használjon. A peridotit, olivin-dolerit és olivin megfelelő kőtípusok.
- **Ne használjon a kályhában se könnyű, porózus kerámia „köveket”, se lágy szappankövet! Ezek a melegítés során nem vesznek fel elegendő hőt, ami a fűtőelemek károsodását okozhatja.**
- Mossa le a port a kövekről, mielőtt a kályhába helyezi azokat.

A kövek elhelyezése során kérjük, ügyeljen az alábbiakra:

- Ne ejtse a köveket a kályhába.
- Ne szorítson köveket a fűtőelemek közé.
- Ritkán rakja a köveket, hogy a levegő tudjon mozogni közöttük.
- Úgy rakja a köveket, hogy azok egymást tartsák és ne nehezdedjenek teljes súlyukkal a fűtőelemekre.
- A köveket ne halmozza magasra a kályha tetején.
- A kályha kőtároló terébe vagy a kályha közelébe ne helyezzen olyan tárgyakat vagy eszközöket, amelyek módosíthatják a kályhán keresztül áramló levegő mennyiségét vagy irányát.

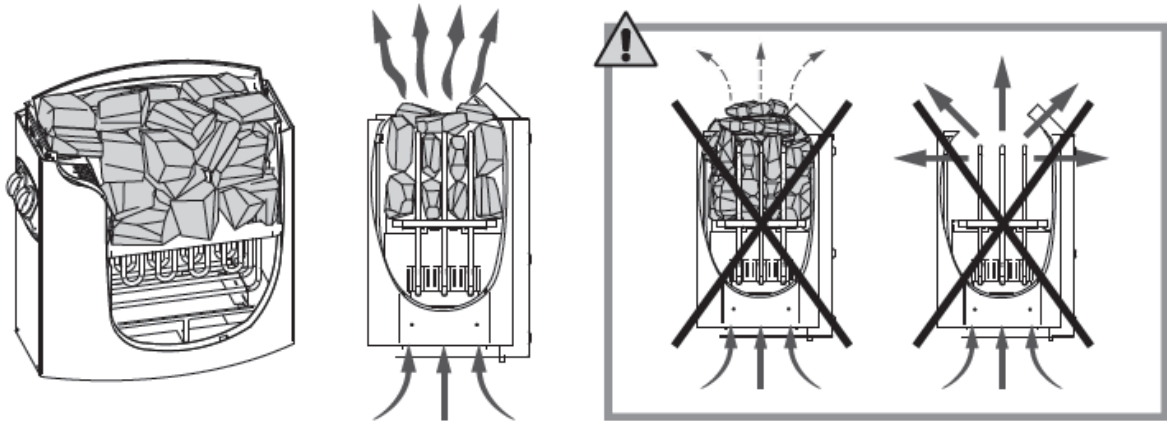

1. ábra

A szaunakövek felrakása

1.1.1 Karbantartás

A nagy hőmérséklet-ingadozás hatására a szaunakövek a használat során szétesnek. A sauna gyakori használata esetén évente legalább egyszer vagy még gyakrabban rendezze át a köveket. Ezzel egyidőben távolítsa el a kályha alsó részén található kődarabokat, és a szétesett köveket cserélje újakra. Ezáltal a kályha fűtőképessége optimális marad és a túlmelegedés veszélye elkerülhető.

1.2. A szauna fűtése

A kályha első működtetése során mind a kályha, mind a kövek szagot bocsátanak ki. A szag távozásához a szaunakabin hatékony szellőzése szükséges.

A szaunakabinnak megfelelő kályhateljesítmény esetén a megfelelően szigetelt szauna körülbelül egy óra alatt fűthető fel a szaunázáshoz szükséges hőmérsékletre (> 2.3.). A szaunakövek általában a szaunakabinnal egyszerre érik el a szaunázáshoz megfelelő hőmérsékletet. A szaunakabin megfelelő hőmérséklete körülbelül 65-80 °C.

1.3. A kályha használata

A kályha bekapcsolása előtt mindig győződjön meg arról, hogy a kályha tetején vagy a megadott biztonsági távolságon belül nincs semmilyen tárgy! > 1.6.

- A BC45, BC60 és BC80 kályhamodellek időzítővel és termosztáttal felszereltek. Az időzítő a kályhabekapcsolási idő, a termosztát pedig a megfelelő hőmérséklet beállítására szolgál.

> 1.3.1.-1.3.4.

- A BC45E, BC60E, BC80E és BC90E kályhamodelleket külön vezérlőegység vezérli. Lásd a kiválasztott vezérlőegység modell használati útmutatóját.

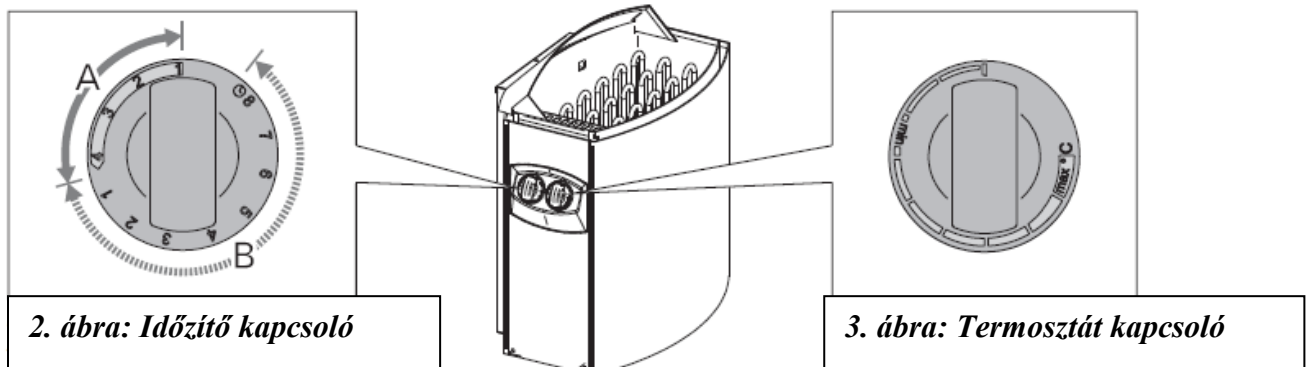

1.3.1. A kályha bekapcsolása



Fordítsa az időzítő kapcsolót az „on” (be) tartományba (2. ábra A tartomány, 0-4 óra). A kályha azonnal fűteni kezd.

1.3.2. Időzítés (időzített bekapcsolás)



Fordítsa az időzítő kapcsolót a „pre-setting” (időzítés) tartományba (2. ábra B tartomány, 0-8 óra). A kályha akkor kezd el fűteni, amikor az időzítő visszafordítja a kapcsolót az „on” (be) tartományba. Ezt követően a kályha körülbelül négy órán keresztül bekapcsolt állapotban marad.

Példa: Szeretne elmenni egy háromórás sétára, majd utána szaunázni egyet. Fordítsa az időzítő kapcsolót a „pre-setting” (időzítés) tartományba a 2-es számhoz.

Az időzítő elindul. Két óra elteltével a kályha fűteni kezd. Mivel körülbelül egy óra szükséges a szauna felfűtéséhez, az megközelítőleg három óra múlva áll készen a szaunázásra, azaz akkor, amikor Ön visszaér a sétából.

1.3.3. A kályha kikapcsolása



Amikor az időzítő a kapcsolót visszafordítja nulla állásba, a kályha kikapcsol. A kályhát az időzítő kapcsoló nulla állásba fordításával Ön is bármikor kikapcsolhatja.

Szaunázás után kapcsolja ki a kályhát. Néha tanácsos a kályhát még egy ideig bekapcsolt állapotban hagyni, hogy a szauna fa elemei megfelelően kiszáradjanak.

FIGYELEM! Mindig ellenőrizze, hogy a kályha kikapcsolt-e és leállította-e a fűtést, miután az időzítő a kapcsolót nulla állásba fordította!

1.3.4. A hőmérséklet beállítása

A termosztát (3. ábra) rendeltetése az, hogy a szaunakabin hőmérsékletét a kívánt szinten tartsa. Tapasztalja ki az Ön számára legmegfelelőbb beállítást.

Elsőként állítsa be a maximum pozíciót. Ha a szaunázás során a hőmérséklet túl magasra emelkedik, fordítsa el a kapcsolót kissé az óramutató járásával ellentétes irányban. Ne feledje, hogy a maximális tartományban egy kis elmozdulás is jelentősen megváltoztatja a szauna hőmérsékletét.

1.4. Víz felöntése a felhevült kövekre

A szaunakabin levegője a melegítés során szárazzá válik. A szauna megfelelő páratartalom szintjének eléréséhez vizet kell locsolni a felhevült kövekre. A hő és a gőz különbözőképpen hat az emberekre – tapasztalja ki az Ön számára legmegfelelőbb hőmérsékletet és páratartalmat.

FIGYELEM! A felöntő kanál maximális térfogata 0,2 liter. Ha túl sok vizet locsol a kövekre, annak csak egy része párolog el, a visszamaradó rész pedig forrásban lévő víz formájában a szaunázókra fröccsenhet. Soha ne locsoljon vizet a kövekre, ha a kályha közelében emberek tartózkodnak, mert a forró gőz megégetheti bőrüket!

FIGYELEM! A felhevült kövekre locsolandó víznek a tiszta háztartási víz követelményeinek kell megfelelnie (1. táblázat). Kizárólag szaunavízhez készült, speciális illatanyagok használhatók. Kövesse a csomagoláson található útmutatót!

Víztulajdonság	Hatás	Javaslat
Humusztartalom	Szín, íz, lerakódások	< 12 mg/l
Vastartalom	Szín, szag, íz, lerakódások	< 0,2 mg/l
Keménység: a legfontosabb anyagok: mangán (Mn) és mész, azaz kalcium (Ca).	Lerakódások	Mn: < 0,05 mg/l Ca: < 100 mg/l
Klóros víz	Egészségügyi kockázat	Használata tilos
Tengervíz	Gyors korrózió	Használata tilos

1. táblázat Vízminőségre vonatkozó követelmények

1.5. Szaunázási útmutató

- Elsőként mosakodjon meg.
- Addig maradjon a szaunában, amíg jól érzi magát.
- Felejtse el minden problémát és lazítson.
- A szaunázás hallgatóságos szabályai szerint nem zavarhat más szaunázókat hangos beszéddel.
- Ne űzze ki a szaunából a többi szaunázót azzal, hogy túl sok vizet locsol a kövekre.
- Szükség szerint hűtse bőrét. Ha egészségi állapota jó, úszhat egyet, ha van a közelben úszóhely vagy medence.
- Szaunázás után mosakodjon meg.
- Pihenjen kicsit és hagyja, hogy pulzusa visszaálljon a normális szintre. Igyon friss vizet vagy egy frissítő italt, hogy folyadékháztartása visszaálljon a normális szintre.

1.6. Figyelmeztetések

- **Ha hosszú időket tölt a szaunában, testhőmérséklete megemelkedik, ami veszélyes lehet.**
- **A forró kályhát ne érintse meg, mivel a kövek és a külső felület megégetheti bőrét.**
- **A gyermekeket tartsa távol a kályhától.**
- **Fiatalok, fogyatékkal élők vagy betegek egyedül ne használják a szaunát.**
- **A szaunázás egészségügyi okokból adódó esetleges korlátozásaival kapcsolatban kérje kezelőorvosa véleményét.**
- **A csecsemők szaunáztatását illetően kérje a gyermekegészségügyi központ véleményét.**
- **A szaunában nagyon óvatosan közlekedjen, mert a pad és a padlórészek csúszósak lehetnek.**
- **Alkohol fogyasztását, erős gyógyszer vagy narkotikumok bevitelét követően ne menjen a felfűtött szaunába.**
- **Ne aludjon a felfűtött szaunában.**
- **A tengeri levegő és a nedves éghajlat a kályha fémfelületein korróziót okozhat.**
- **Ne használja a szaunát ruhaszárításra, mivel ez tűzveszélyt okozhat. A túl magas páratartalom károsíthatja az elektromos berendezéseket is.**

1.7. Hibaelhárítás

Figyelem! Minden javítási műveletet csak képzett karbantartó személy végezhet!

A kályha nem fűt.

- Ellenőrizze a kályha biztosítékainak megfelelő állapotát.
- Ellenőrizze a csatlakozó kábel csatlakozását (> 3.3.).
- Fordítsa az időzítő kapcsolót az „on” (be) tartományba (> 1.3.1.).
- Fordítsa a termosztátot magasabb beállításba (> 1.3.4.).
- Ellenőrizze, hogy a túlmelegedés elleni védelem nem oldott-e le. Az időzítő működik, a kályha azonban nem fűt. (> 3.5.).

A szaunakabin lassan melegszik fel. A szaunakövekre locsolt víz gyorsan lehűti a köveket.

- Ellenőrizze a kályha biztosítékainak megfelelő állapotát.
- Ellenőrizze, hogy a kályha bekapcsolt állapotában minden fűtőelem izzik-e.
- Fordítsa a termosztátot magasabb beállításba (> 1.3.4.).
- Ellenőrizze, hogy elegendő-e a kályhateljesítmény (> 2.3.).
- Ellenőrizze a szaunaköveket (> 1.1.). A túl szorosan felrakott kövek, a kövek idővel történő leülepedése vagy a nem megfelelő kötípus akadályozhatja a kályhán keresztüli levegőáramlást, ami csökkent fűtési hatásfokot eredményez.
- Ellenőrizze a szaunakabin szellőzés megfelelő kialakítását (> 2.2.).

A szaunakabin gyorsan felmelegszik, a kövek hőmérséklete azonban továbbra sem megfelelő. A kövekre locsolt víz átfolyik.

- Fordítsa a termosztátot alacsonyabb beállításba (> 1.3.4.).
- Ellenőrizze, hogy a kályhateljesítmény nem túl nagy-e (> 2.3.).
- Ellenőrizze a szaunakabin szellőzés megfelelő kialakítását (> 2.2.).

A szaunakabin egyenetlenül melegszik fel.

- Ellenőrizze, hogy a kályha a helyes magasságban lett-e beépítve. A kályha akkor fűti a szaunát a legjobban, ha a padlótól 100 mm magasságban építik be. A maximális beépítési magasság 200 mm (> 3.2.).

A kályha közelében lévő burkolat vagy egyéb anyag gyorsan elfeketedik.

- Ellenőrizze a biztonsági távolságokra vonatkozó követelmények betartását (> 3.1.).
- Ellenőrizze a szaunaköveket (> 1.1.). A túl szorosan felrakott kövek, a kövek idővel történő leülepedése vagy a nem megfelelő kötípus a környező anyagok túlmelegedését okozhatja.
- Tanulmányozza a 2.1.1. részt is.

A szauna szagot bocsát ki.

- Tanulmányozza az 1.2. részt.
- A forró kályha felerősítheti azokat a levegőben jelenlévő szagokat, amelyek azonban nem a szaunából vagy a kályhából származnak. Például: festék, ragasztó, olaj, fűszer.

A kályha hangot ad ki.

- BC: Az időzítő egy mechanikus eszköz és normál működés esetén ketyegő hangot ad. Ha az időzítő a kályha kikapcsolt állapotában is ketyeg, ellenőrizze az időzítő vezetékeit.
- Az alkalmanként hallható durranó hangot legvalószínűbben a hő hatására megrepedő kövek okozzák.
- A kályha alkatrészeinek hőtágulása adhat hangokat a kályha felmelegedése során.

2. SZAUNAKABIN

2.1. A szaunakabin felépítése

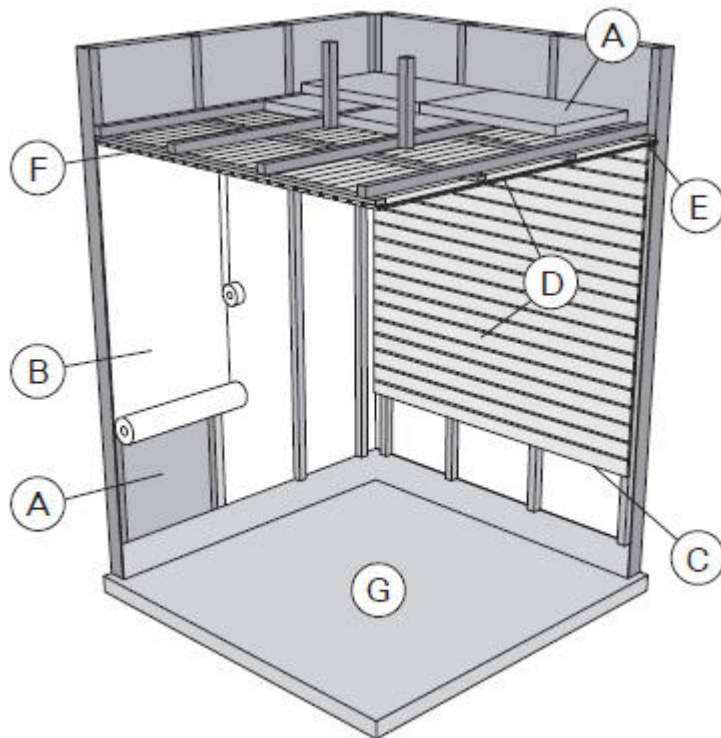

4. ábra

- A. 50-100 mm vastag hőszigetelő gyapot. A szaunakabin gondos hőszigetelést igényel a fűtőteljesítmény mérsékelt alacsony szinten tartása érdekében.
- B. Nedvesség elleni védelem, pl. alumíniumpapír. A papír fényes oldalát fordítsa a szauna felé. A széleket ragassza le alumínium szalaggal.
- C. Körülbelül 10 mm-es szellőző rés a nedvesség elleni védelem és a burkolat között (ajánlott).
- D. Kis tömegű, 12-16 mm vastag burkolólap. A burkolás megkezdése előtt ellenőrizze a kályhához és padokhoz szükséges fali elektromos vezetékeket és merevítéseket.
- E. Körülbelül 3 mm-es szellőző rés a fal és a mennyezeti burkolat között.
- F. A szauna magassága általában 2100-2300 mm. A minimális magasság a kályhától függ (lásd 2. táblázat). A felső pad és a mennyezet közötti tér ne haladja meg az 1200 mm-t.
- G. Használjon kerámia anyagból készült padlóburkolót és sötét színű fugázót. A szaunakövekről leváló részek és a szaunavízben található szennyezőanyagok foltossá tehetik és/vagy károsíthatják az érzékeny padlóburkolatot.

FIGYELEM! Érdeklődjön a tűzvédelmi hatóságoknál arról, hogy a tűzfal mely részei szigetelhetők. A használat alatt lévő füstcsatornák szigetelése tilos.

FIGYELEM! A közvetlenül a fal vagy mennyezet mellett beépített könnyű védőburkolatok tűzveszélyesek lehetnek.

2.1.1. A szaunafalak elfeketedése

Teljesen normális jelenség, hogy a szaunakabin fafelületei idővel elfeketednek. Ezt a folyamatot felgyorsíthatják az alábbi tényezők:

- napfény
- a kályhából származó hő
- a falon használt védőszerek (a védőszerek hőállóság szintje alacsony)
- a szaunakövekről leváló, levegőáramlással felemelkedő finom részecskék.

2.2. A szaunakabin szellőzése

A szaunakabin levegőjének óránként hatszor tanácsos cserélődni. Az 5. ábra különböző szaunakabin szellőzési megoldásokat mutat be.

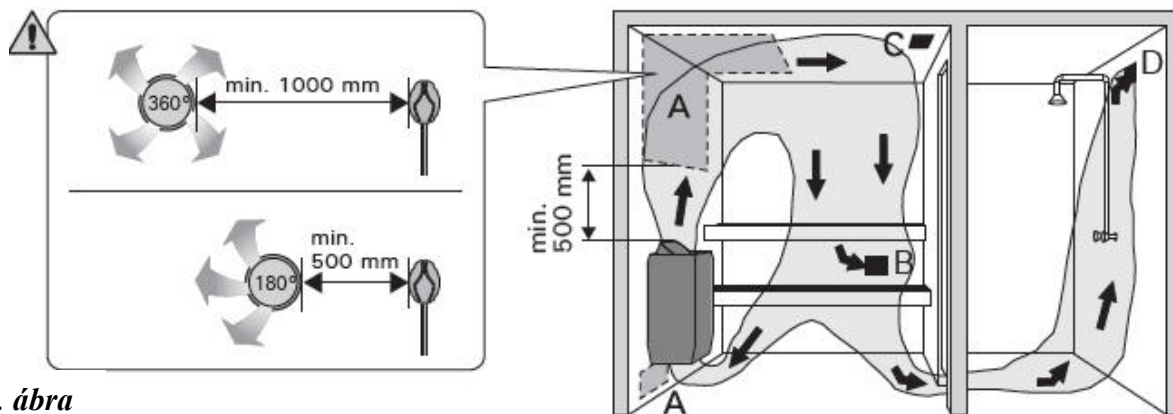

5. ábra

- Levegőellátó nyílás helye. Mechanikus szívószellőztetés alkalmazása esetén a levegőellátó nyílást a kályha fölött helyezze el. Gravitációs szellőztetés használata esetén a levegőellátó nyílást a kályha alatt vagy mellett alakítsa ki. A levegőellátó cső átmérője 50-100 mm legyen. **BC-E: Ne helyezze el a levegőellátó nyílást úgy, hogy az áramló levegő lehűtse az érzékelőt (tanulmányozza a vezérlőegység beszerelési útmutatóban található hőmérsékletérzékelő beszerelési útmutatót)!**
- Levegőelvezető nyílás. A levegőelvezető nyílást a padló közelében helyezze el, a kályhától lehető legtávolabb. A levegőelvezető cső átmérője a levegőellátó cső átmérőjének kétszerese legyen.
- Opcionális szárító nyílás (amely fűtés és szaunázás közben lezárt állapotban van). A szauna kiszárítható úgy is, hogy szaunázás után nyitva hagyja az ajtót.
- Ha a levegőelvezető nyílás a tisztálkodó helyiségben található, a szaunaajtó alatti nyílás legalább 100 mm-es legyen. A mechanikus szívószellőztetés kötelező.

2.3. A kályha teljesítménye

Ha a falakat és a mennyezetet burkolat fedi, és a burkolat mögötti hőszigetelés megfelelő, a kályhateljesítményt a szauna légköbmétere határozza meg. Szigetetlen falak (tégla, üvegtégla, üveg, beton, csempe, stb.) esetén nagyobb kályhateljesítmény szükséges. Szigetetlen falnégyzetméterenként adjon 1,2 m³-t a szauna légköbméteréhez. Például egy 10 m³-es, üvegajtós szauna teljesítményigénye megegyezik egy kb. 12 m³-es szaunakabin teljesítményigényével. Farönk szaunakabin falak esetén szorozza meg a szauna

légköbméterét 1,5-tel. Válassza ki a megfelelő kályhateljesítményt a 2. táblázatból.

2.4. A szaunakabin higiénája

A szaunázás során javasolt a padon törölközőket használni, hogy ne kerüljön veríték a padokra.

A szauna padjait, falait és padlóját tanácsos legalább hathavonta alaposan lemosni. Használjon súrolókefét és szauna tisztítószeret.

A kályháról a port és a szennyeződések nedves kendővel törölje le. A kályhán található vízkőfoltok eltávolításához használjon 10%-os citromsav oldatot, majd öblítse le.

3. BEÉPÍTÉSI ÚTMUTATÓ

3.1. Beépítés előtt

A kályha beépítése előtt tanulmányozza a beépítési útmutatót. Ellenőrizze az alábbiakat:

- A kályha teljesítménye és típusa a szaunakabinnak megfelelő? **Kövesse a 2. táblázatban megadott légköbméter értékeket!**
- A tápfeszültség a kályhának megfelelő?
- A kályha elhelyezése teljesíti a 6. ábrán és 2. táblázatban megadott, biztonsági távolságokra vonatkozó minimális követelményeket?

A kályha beépítésének feltétlenül ezen értékek szerint kell történnie! Ezen értékek figyelmen kívül hagyása tűzveszélyt okoz. A szaunakabinba csak egy elektromos kályha építhető be.

Kályha Modell és méretek	Telje- sítmény	Szaunakabin			Elektromos csatlakozások				
		Légköbméter	Magasság		400 V 3N~ Csatlakoztató kábel	Biztosíték	230 V 1N~ Csatlakoztató kábel	Biztosíték	Érzékelőhöz (BC-E)
Szélesség		> 2.3.			Lásd a 8. ábrát: Az adatok csak a csatlakoztató kábelre vonatkoznak!				
• BC 480 mm									
• BC-E 450 mm									
Mélység 310 mm									
Magasság 540 mm									
Súly 11 kg									
Kövek		min.	max.	min.					
max. 25 kg	kW	m3	m3	mm	mm2	A	mm2	A	mm2
BC45/ BC45E	4,5	3	6	1900	5 x 1,5	3 x 10	3 x 2,5	1 x 20	4 x 0,25
BC60/ BC60E	6,0	5	8	1900	5 x 1,5	3 x 10	3 x 2,5	1 x 35	4 x 0,25
BC80/BC80E	8,0	7	12	1900	5 x 2,5	3 x 16	3 x 6	1 x 35	4 x 0,25
BC90E	9,0	8	14	1900	5 x 2,5	3 x 16	3 x 10	1 x 50	4 x 0,25

2. táblázat Beépítési adatok

	<p>A kályha legalább 1900 mm magas mélyedésbe építhető be.</p>		
	<p>A min. oldaltól falig, felső padig vagy rácsig</p>	<p>B min.</p>	<p>C min. az előlő felülettől a felső padig vagy korlátig</p>
<p>BC45/BC45E</p>	<p>35</p>	<p>20</p>	<p>35</p>
<p>BC60/BC60E</p>	<p>50</p>	<p>30</p>	<p>50</p>
<p>BC80/BC80E</p>	<p>100</p>	<p>30</p>	<p>80</p>
<p>BC90E</p>	<p>120</p>	<p>40</p>	<p>100</p>

6. ábra Biztonsági távolságok (minden méret milliméterben megadva)

3.2. A kályha falra történő rögzítése

Tanulmányozza a 7. ábrát.

- Rögzítse a falra szerelhető tartókeretet a falhoz a tartókerethez tartozó csavarokkal.
FIGYELEM! A burkolat mögött legyen valamilyen tartóelem, például egy deszkalap, hogy a rögzítő csavarokat a burkolatnál vastagabb faanyagba lehessen becsavarozni. Ha a burkolat mögött nincsenek deszkalapok, azok ráerősíthetők a burkolatra is.
- A kályha jobb- illetve balkezessége változtatható a tartókeretre történő megfelelő felszereléssel. Győződjön meg róla, hogy a rögzítő kapocs megfelelően illeszkedik a nyílásba.
- Emelje a kályhát a falon lévő tartókeretre úgy, hogy a tartókeret alsó részén található rögzítő kampók a kályhatest pereme mögé kerüljenek. Rögzítse a kályhaperemet csavarral a tartókeretre.

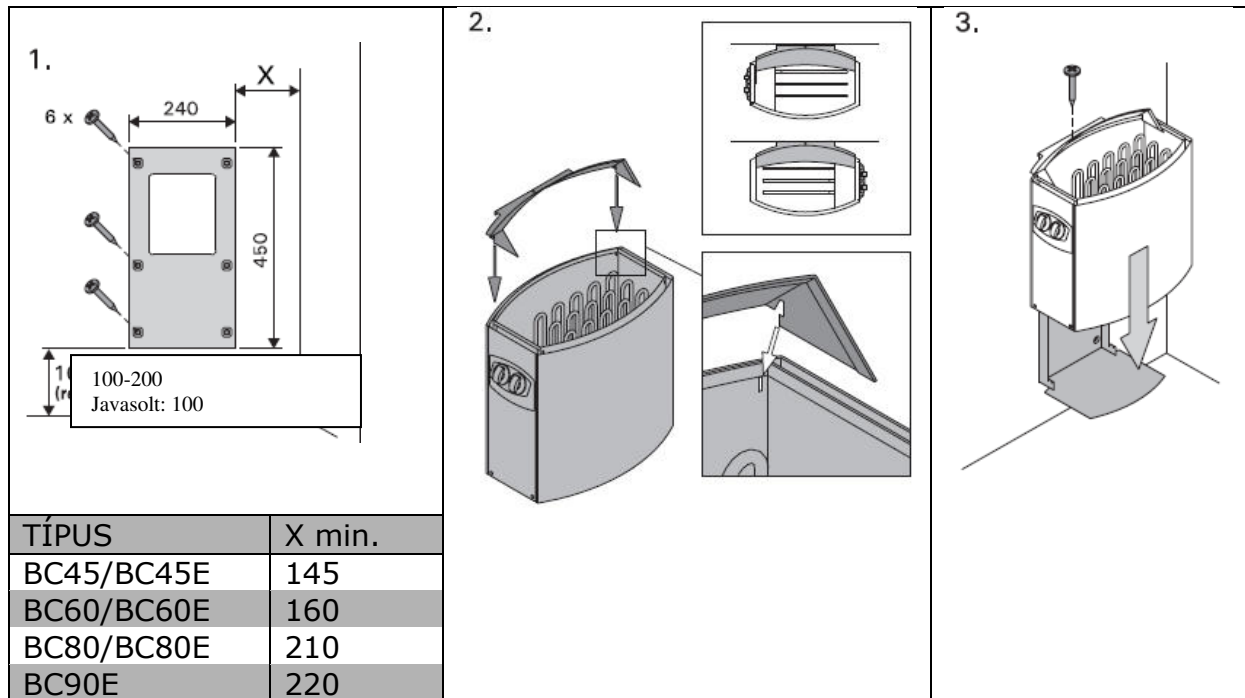

7. ábra A kályha falra történő rögzítése (minden méret milliméterben megadva)

3.3. Elektromos csatlakozások

A kályha elektromos hálózathoz történő csatlakoztatását kizárólag arra jogosult, képzett villanyszerelő végezheti, a hatályos előírásoknak megfelelően.

- A kályha félig rögzítetten csatlakozik a szaunafalon található elágazódobozhoz (8. ábra: A). A elágazódoboz legyen fröccsenő víz ellen védett, és a padlótól számított távolsága ne haladja meg az 500 mm-t.
- A csatlakoztató kábel (8. ábra: B) H07RN-F típusú gumikábel vagy annak megfelelő legyen.

FIGYELEM! A hő hatására történő elrúgódás miatt PVC-szigetelésű vezeték kályha csatlakoztató kábelként történő használata tilos.

- Ha a csatlakoztató és beépítő kábelek a sauna belső terének padlójától 1000 mm-nél magasabban vannak vagy a szaunafalakon belül találhatóak, terhelés alatt minimum 170°C-os hőmérsékletet kell kibírniuk (például SSJ).

A sauna padlójától 1000 mm-nél magasabba beépített elektromos berendezéseknek 125°C-on történő használatra vonatkozó engedéllyel kell rendelkezniük (T125 jelölés).

- A tápcsatlakozók mellett a BC kályhák az elektromos fűtés vezérlését lehetővé tevő csatlakozóval (P) vannak felszerelve (10. ábra). A feszültségvezérlést a kályha továbbítja bekapcsolt állapotban. Az elektromos fűtésvezérlő kábel közvetlenül a kályha elágazódobozába fut be, onnan pedig a csatlakoztató kábel keresztmetszetével azonos keresztmetszetű gumikábel mentén a kályha sorozatkapcsához.

- A csatlakozódoboz fedelének lezárásakor győződjön meg a fedél felső peremének megfelelő elhelyezkedéséről. Ha a felső perem nem megfelelően helyezkedik el, víz kerülhet a csatlakozódobozba. 8. ábra.

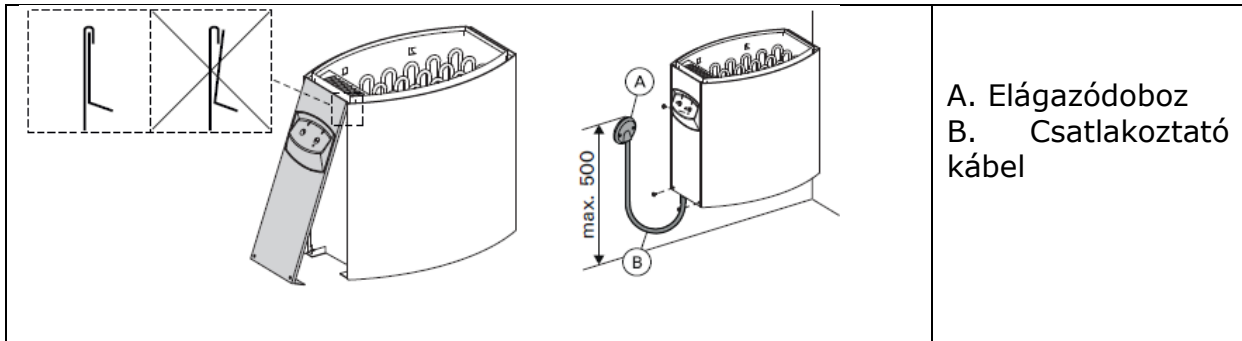

A. Elágazódoboz
B. Csatlakoztató kábel

8. ábra: A csatlakozódoboz fedelének lezárása (minden méret milliméterben megadva)

3.3.1. Az elektromos kályha szigetelési ellenállása

Az elektromos berendezések végső vizsgálatakor, a kályha szigetelési ellenállásának mérésekor előfordulhat, hogy „szivárgás” észlelhető. Ennek az az oka, hogy a fűtőelemek szigetelőanyaga nedvességet vett fel a levegőből (tárolás, szállítás). A kályha néhány alkalommal történő üzemeltetését követően a nedvesség távozik a fűtőelemekből.

Ne csatlakoztassa a kályha tápvezetékét áram-védőkapcsolón keresztül!

3.4. A vezérlőegység és az érzékelők beszerelése (BC-E)

A vezérlőegység részletes útmutatót tartalmaz az egység falra történő rögzítésére. A hőmérsékletérzékelőt a szaunakabin falára, a kályha fölé szerelje fel. A kályha oldaltengelyére szerelje fel, a mennyezettől 100 mm-re lefelé. 6. ábra.

Ne helyezze el a levegőellátó nyílást úgy, hogy az áramló levegő lehűtse a hőmérsékletérzékelőt! 5. ábra.

3.5. A túlmelegedés elleni védelem visszaállítása

Ha a szaunakabin levegője veszélyesen felmelegszik, a túlmelegedés elleni védelem huzamosan lekapcsolja a kályha áramellátását. A kályha lehűlését követően a túlmelegedés elleni védelem visszaállítható.

BC

A visszaállító gomb belül, a kályha csatlakozódobozában található (9. ábra). A túlmelegedés elleni védelmet kizárólag elektromos szerelések végzésére jogosult személy állíthatja vissza.

A gomb megnyomása előtt ki kell deríteni a hiba okát.

- A kövek szétmállottak és egymásra ülepedtek?
- A kályha hosszú ideig volt bekapcsolt állapotban használat nélkül?
- A termosztát érzékelője nincs a helyén vagy törött?
- A kályhát ütés vagy rázkódás érte?

BC-E

Tanulmányozza a vezérlőegységre vonatkozó beépítési útmutatót.

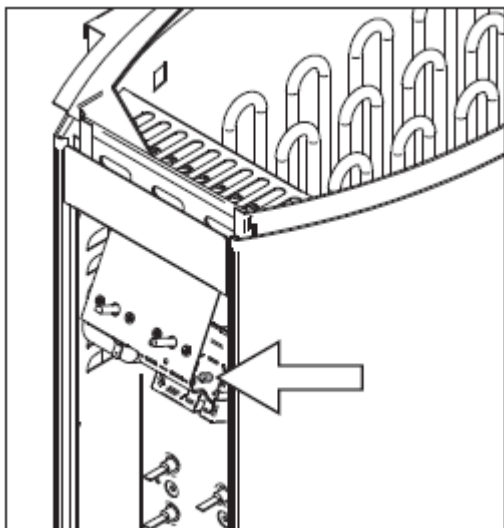

9. ábra *Túlmelegedés elleni védelem visszaállító gomb*

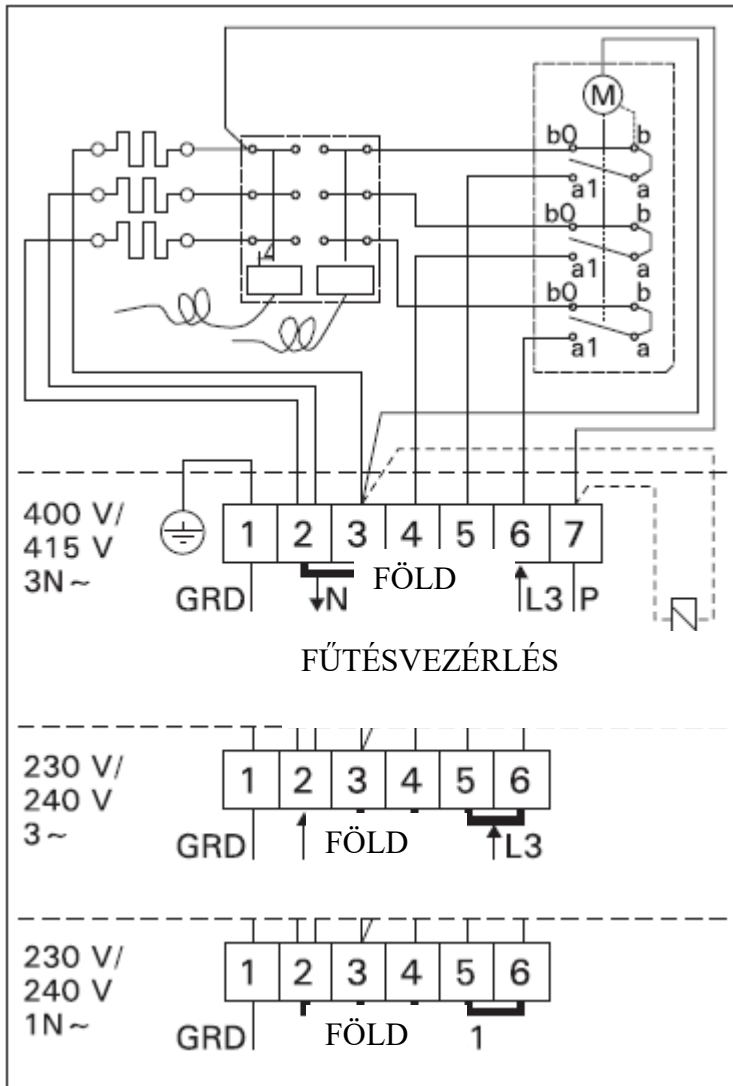

10. ábra BC kályha elektromos csatlakozásai

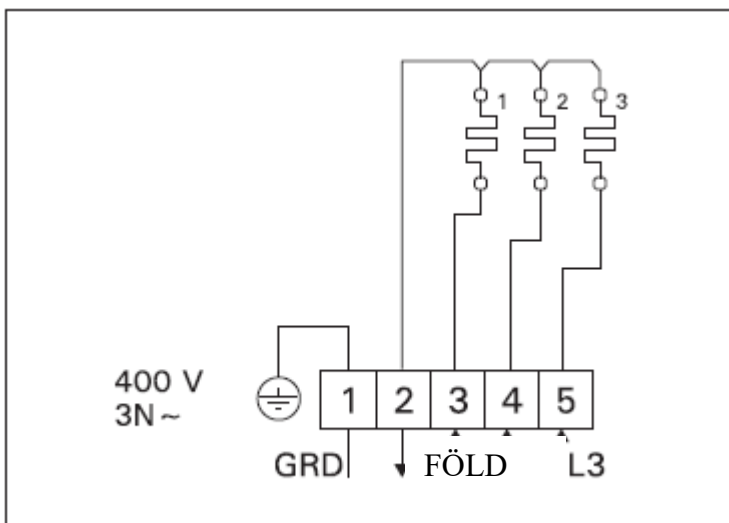

11. ábra BC kályha elektromos csatlakozásai

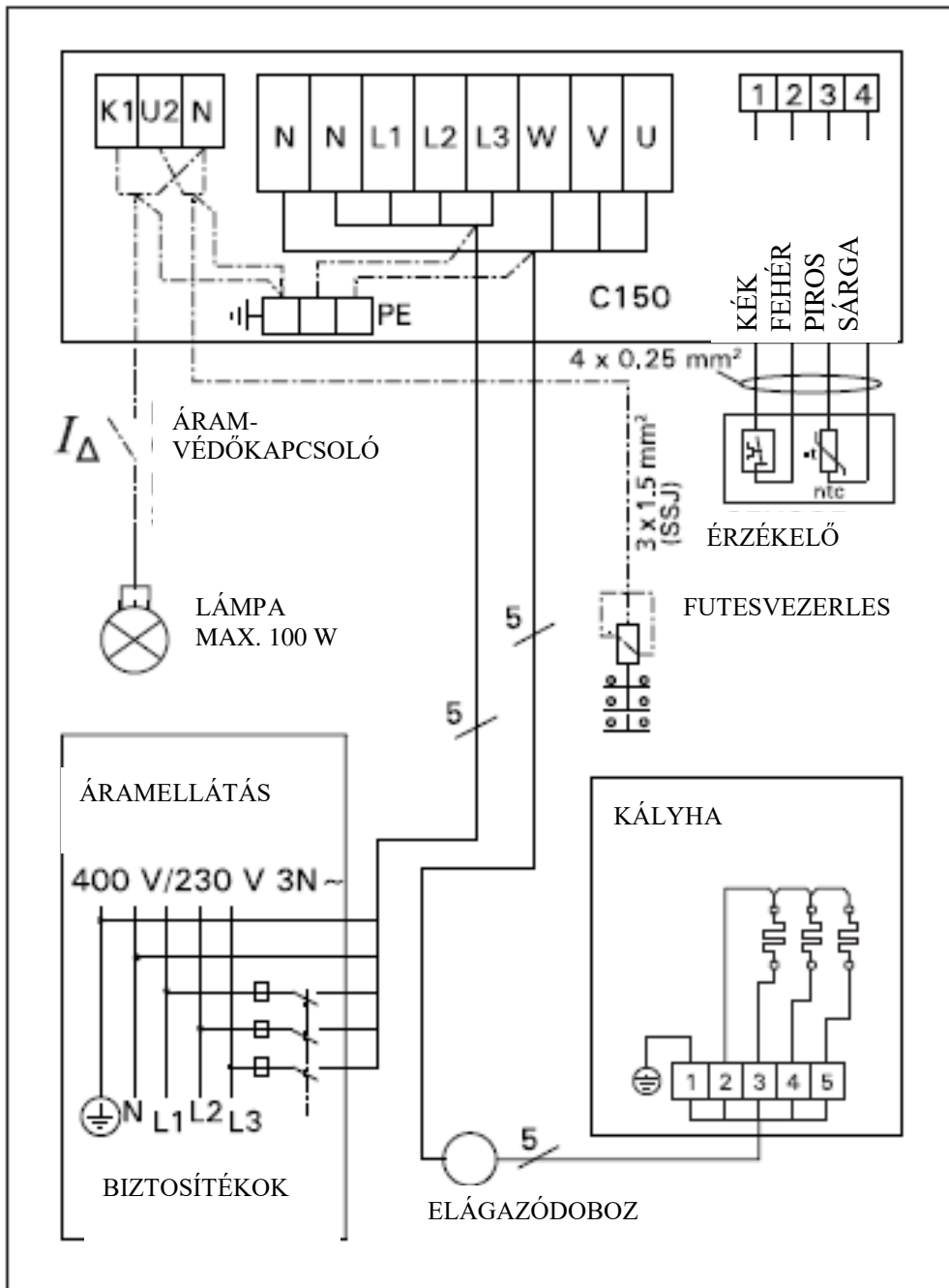

12a. ábra C-150-es vezérlőegység és BC-E kályha 3-fázisú elektromos csatlakozásai

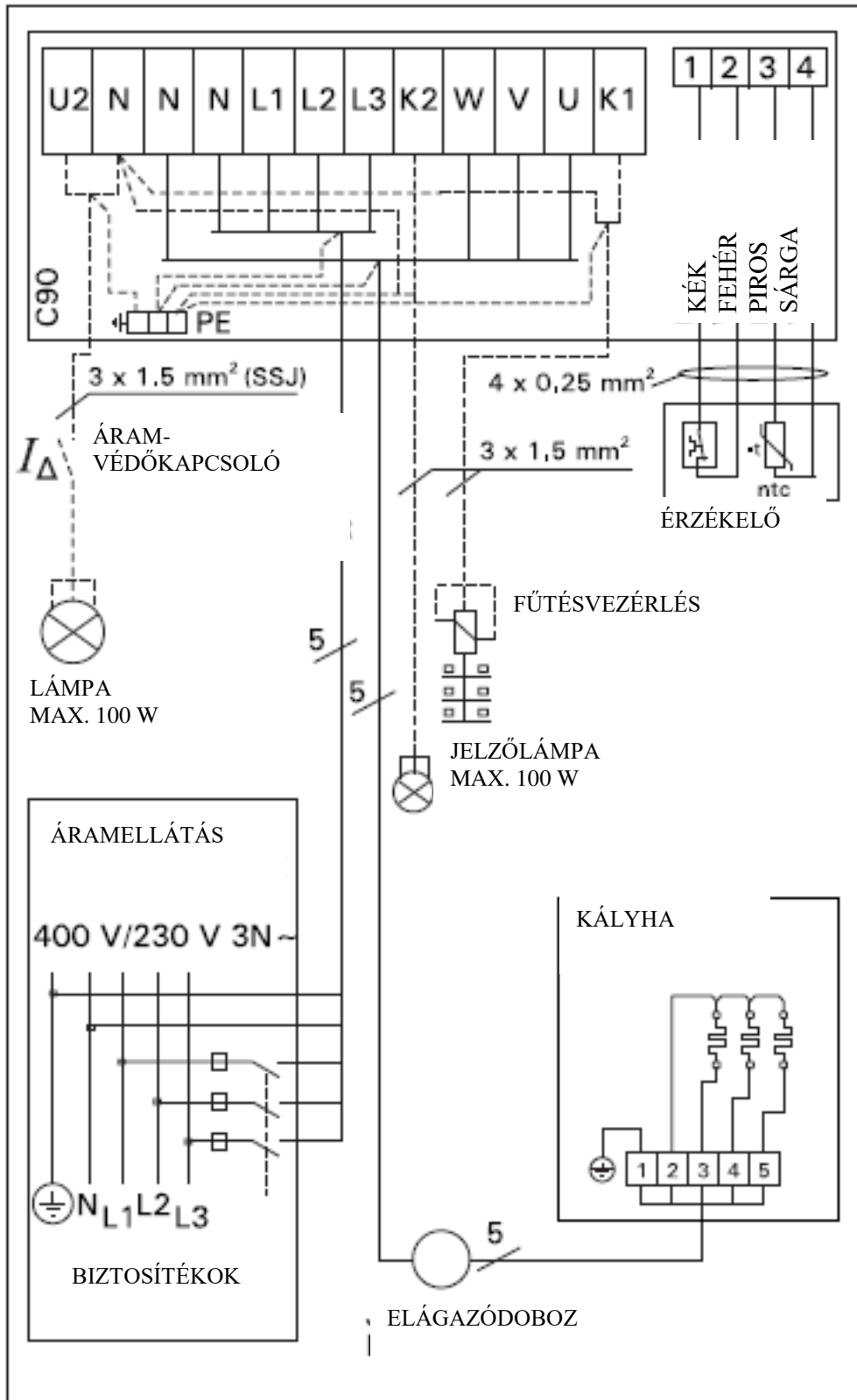

12b. ábra C90-es vezérlőegység és BC-E kályha 3-fázisú elektromos csatlakozásai

4. PÓTALKATRÉSZEK

1	ZSB-224	1500 W/230 V
2	ZSB-226	2000 W/230 V
3	ZSB-228	2670 W/230 V
4	ZSB-229	3000 W/230 V (BC90E)
5	ZSK-510	⌚ (BC)
6	ZSB-125	⌚ (BC)
7	ZSK-520	°C (BC)
8	ZSB-115	°C (BC)

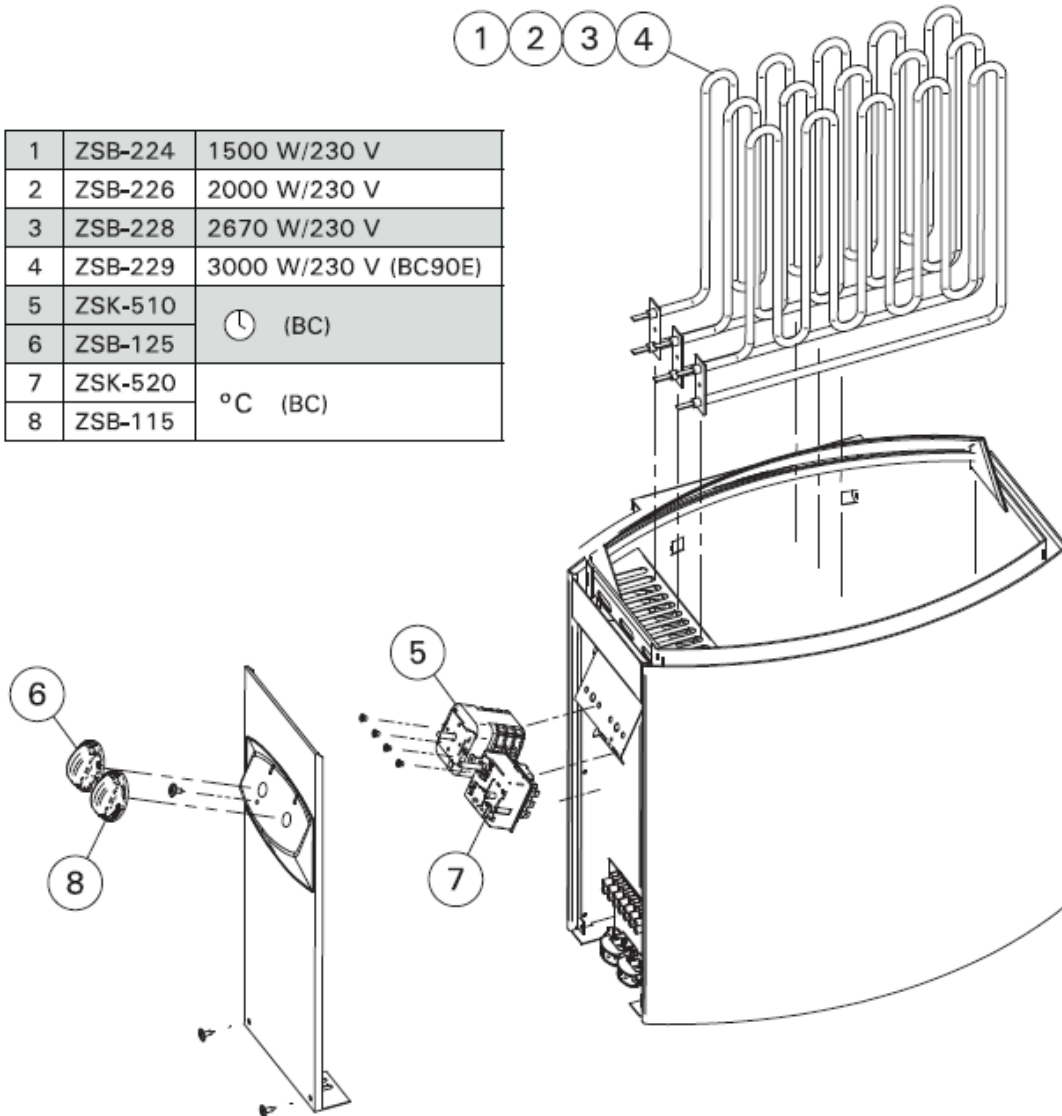

HARVIA
 Harvia Oy
 PL12
 40951 Muurame
 Finland
www.harvia.fi

Instruction Manual

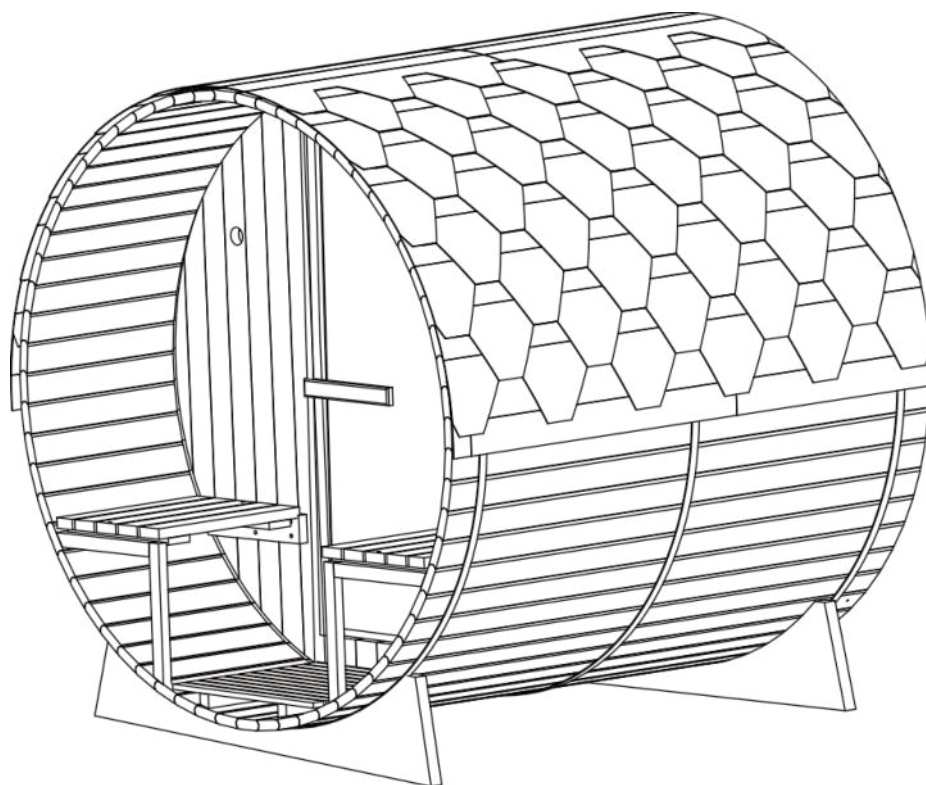

— Infraroșul face viața mai sănătoasă —

Datorită îmbunătățirii continue a produsului, produsul ilustrat în acest manual de instrucțiuni poate varia ușor față de produsul real.

Recomandari

Cititi cu atentie acest manual inainte de a utiliza sauna pentru prima data.

Vă recomandăm să îl păstrați într-un loc sigur pentru referințe viitoare.

- Lemnul este un element viu, pentru a-și menține aspectul original, este important să tratați exteriorul lemnului împotriva umezelii.
- Instalați sauna pe o suprafață perfect plană și tare.
- Nu utilizați produse de curățare lichide. Deconectați sauna înainte de curățare și utilizați o cârpă umedă.
- Protejați cablul electric al saunei pentru a evita strivirea sau ciupirea acestuia.
- Înainte de a înlocui anumite componente, asigurați-vă că acestea sunt specificate de producător sau că au aceleași caracteristici ca piesele originale. Înlocuirea incorectă poate provoca un incendiu, un scurtcircuit sau deteriorarea saunei. Vă recomandăm cu tărie să utilizați un tehnician calificat.
- Pentru a evita riscul de arsuri sau șocuri electrice, nu utilizați unelte metalice.
- Nu puneți animale în saună.
- Nu lăsați sauna pornită fără supraveghere.
- Nu lăsați sauna pornită mai mult de 3 ore la o sedinta pentru a evita deteriorarea prematură a echipamentului. După 3 ore de utilizare continuă, opriți sauna timp de cel puțin o oră.
- Vă recomandăm să nu instalați un sistem de blocare pe ușa saunei.
- Verificați conformitatea instalației electrice înainte de a conecta sauna la sursa de alimentare.

Siguranta

IMPORTANT:

Vă rugăm să citiți cu atenție instrucțiunile de siguranță înainte de instalarea și utilizarea cabinei de saună. Acestea sunt esențiale pentru siguranța dumneavoastră, așa că vă rugăm să le respectați cu strictețe.

Feriți-vă de hipertermie, insolație sau epuizare termică care pot fi cauzate sau agravate de nerespectarea instrucțiunilor de siguranță. Simptomele sunt febră, puls rapid, amețeli, leșin, letargie și amorțeală în tot corpul sau într-o parte a acestuia. Efectele sunt: conștientizarea redusă a căldurii, ignorarea riscurilor iminente, pierderea conștienței.

Sauna nu trebuie utilizată de:

- Copii sub 6 ani.
- Persoanele cu reacții severe la lumina soarelui.
- Persoanele în vârstă sau cu dizabilități.
- Persoanele cu afecțiuni medicale anterioare, cum ar fi boli de inimă, hipertensiune arterială sau scăzută, probleme de circulație a sângelui sau diabet zaharat fără consiliere medicală prealabilă.
- Femeile însărcinate. Temperatura excesivă poate pune în pericol fătul.
- Persoanele care suferă de deshidratare, răni deschise, tulburări oculare, arsuri sau insolație.

Copiii cu vârsta cuprinsă între 6 și 16 ani pot folosi sauna cu condiția să fie supravegheați continuu de un adult responsabil și ca temperatura să nu depășească 60 ° C (140 ° F).

În cazul unor probleme de sănătate, medicație sau leziuni ale mușchilor sau ligamentelor, nu utilizați sauna fără a consulta în prealabil un medic și fără a obține aprobarea.

Dacă se poartă implanturi chirurgicale, nu utilizați sauna fără a consulta în prealabil un medic și fără a obține aprobarea acestuia. Nu utilizați sauna după o activitate intensă.

Așteptați 30 de minute pentru ca corpul să se răcească.

Nu petreceți mai mult de 40 de minute în saună la un moment dat. Nu consumați alcool sau droguri înainte sau în timpul sesiunii.

Nu dormiți în saună atunci când este în funcțiune.

Pentru a evita riscul supraîncălzirii, conectați sauna la o priză electrică suficient de puternică și nu conectați alte echipamente electrice la aceeași priză de perete.

Pentru a evita orice risc de electrocutare sau deteriorare a saunei, nu o utilizați:

- În timpul furtunilor.
- În cazul în care cablul electric este deteriorat, acesta trebuie înlocuit de o persoană calificată.
- Dacă cablul electric se supraîncălzește, acesta trebuie verificat de o persoană calificată.
- Dacă trebuie să schimbați un bec, așteptați până când sauna este oprită și răcită.

Uscați-vă mâinile înainte de a conecta sau deconecta electricitatea. Nu

lucrați niciodată cu mâinile sau picioarele ude.

Nu porniți sau opriți rapid electricitatea sau sistemul de încălzire, deoarece acest lucru ar putea deteriora sistemul electric. Nu încercați să reparați sauna singuri fără acordul distribuitorului sau producătorului saunei.

Încercările neautorizate de a-l repara vor anula garanția producătorului.

Nu utilizați niciun tip de detergent în interiorul saunei.







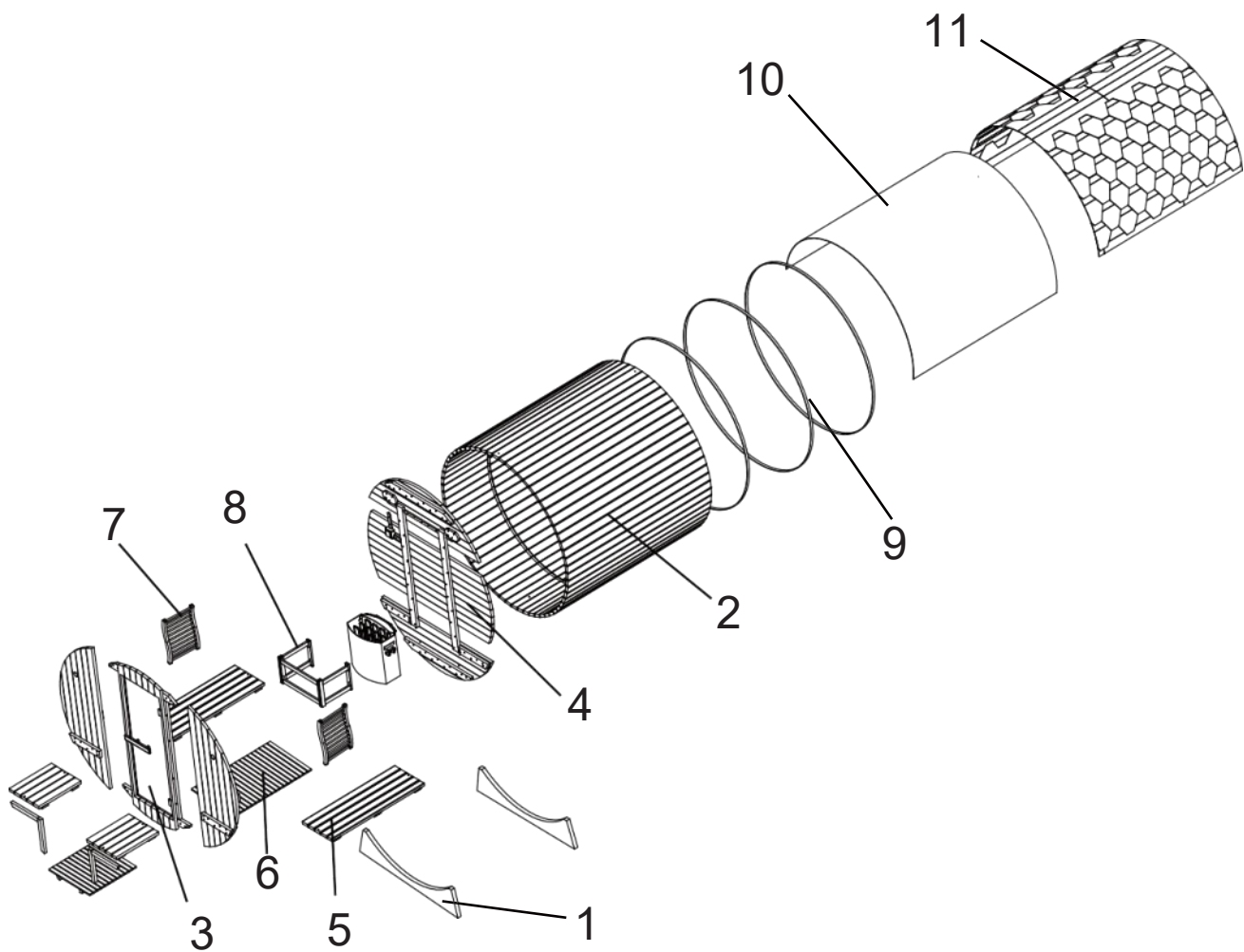





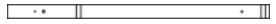
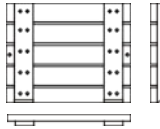

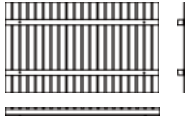
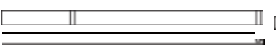
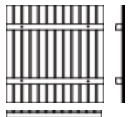
Nu îngrămădiți și nu depozitați obiecte în interiorul sau deasupra saunei.

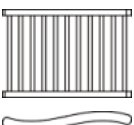
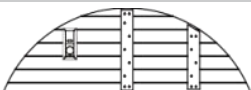
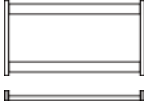
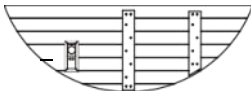
Nu așezați materiale inflamabile sau agenți chimici în apropierea saunei.

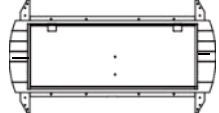



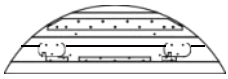
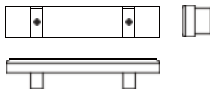
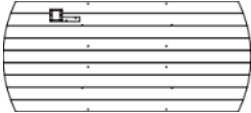
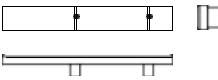
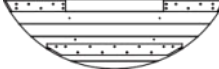
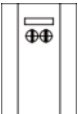
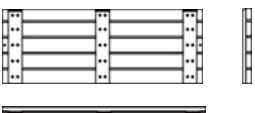
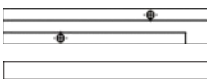

Descriere sauna





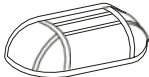
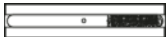

Descriere sauna

1		(1400x300x33mm)2x	5.2		(426x398x30mm)2x
2.1		(1800x93x30mm)2x	5.3		(532x425x50mm)2x
2.2		(1800x93x30mm)1x	6.1		(990x585x40mm) 1x
2.3		(1800x93x30mm)60x	6.2		(535x585x40mm) 1x
2.4		(1800x93x30mm)1x	7		(520x330x65mm)2x
3.1		(1758x575x30mm)1x	8.1		(560x300x40mm)1x
3.2		(1650x575x30mm)1x	8.2		(378x300x40mm)2x
3.3		(1758x952x30mm) 1x	9		3x Cerc butoi
4.1		(1404x80x20mm)1x	10		(3000x1800mm)1x
4.2		(1404x80x20mm)1x	11		(1000x320mm)60x
4.3		(1574x488x30mm) 1x	12		250x50x45mm)1x
4.4		(1758x783x30mm) 1x	13		(350x50x45mm)1x
4.5		(1574x488x30mm) 1x	14		1x Aragaz sauna
5.1		1152x425x50mm)2x	15		(177x80x30mm)1x

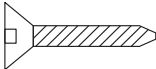
Descriere sauna

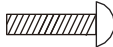
16		1x Vas pentru apă	20		1x Higrometru
17		2x abajur rezistent la explozii	21		1x Clepsidră
18		2x Suport pahar	22		1x Lingura de lemn
19		1x Ciubar din lemn			

							
Ø5x50	Ø4x50	Ø4x30	Ø3x35	Ø4x12	Ø6x70		
44x	20x	8x	66x	240x	2x	2x	

Citiți cu atenție instrucțiunile de asamblare înainte de a începe.

Alegerea locației

Proiectat exclusiv pentru instalare exterioară.

Selectați un spațiu:

- Într-o zonă uscată, pe o suprafață plană stabilă care poate susține greutatea saunei.
- Înălțimea trebuie să fie suficientă pentru a ajunge la tavan și pentru a efectua conexiuni electrice și întreținere.
- Departe de orice sursă de apă, flăcări sau materiale inflamabile.

Sfaturi practice

- Rețineți că asamblarea saunei necesită 3 adulți.
- Identificați clar fiecare panou înainte de a începe
- În timpul asamblării, poziționați cablul de alimentare al saunei astfel încât să fie ușor accesibil.
- Rețineți că există variații între modele.

IMPORTANT:

Vă rugăm să verificați forajul și diametrul găurilor pentru a evita deteriorarea lemnului.

Instrumente necesare



Șurubelniță



Ruletă



Creion



Tăietor



2 Cheie

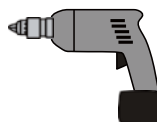

Surubelnita
electrică



Burghiu pentru lemn



Inbus



Scară

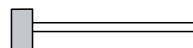

Ciocan de plastic

Instrucțiuni de asamblare

Ø 5 x 50 20BUC

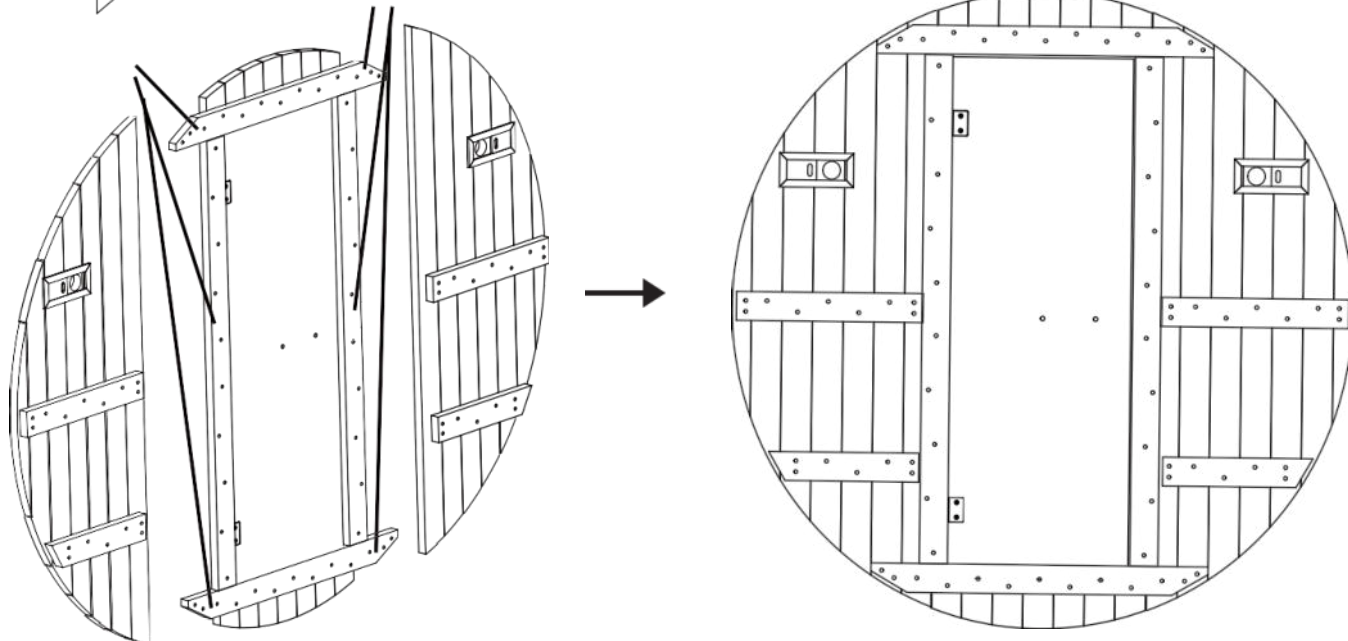

Ø 3 x 35 2BUC

Ø 5 x 50 18BUC

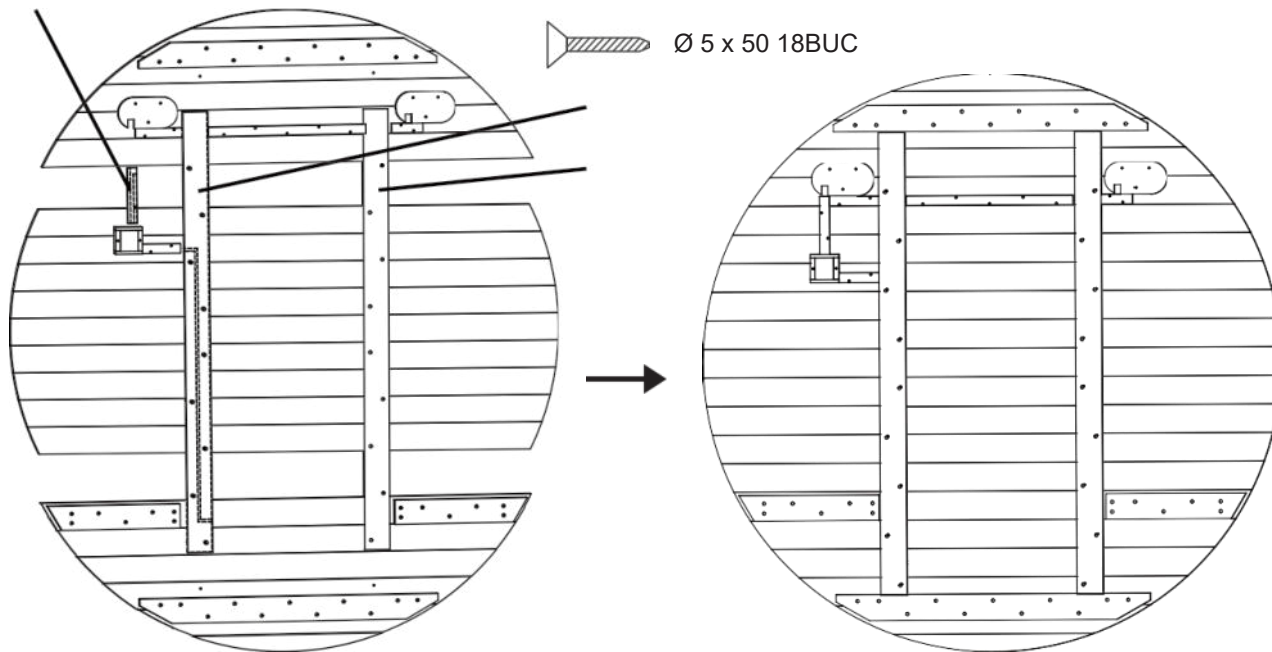

Panourile din față și din spate trebuie asamblate mai întâi ca un întreg.
Panoul frontal este împărțit în trei părți stânga - dreapta, iar panoul din spate este împărțit în trei părți sus - jos.

Instrucțiuni de asamblare

Pașii asamblării

 Ø 5 x 50 2BUC

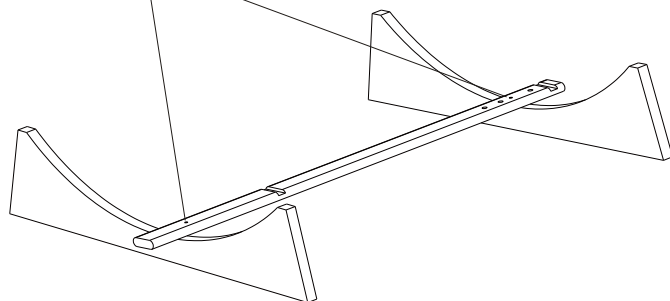

Suport baza

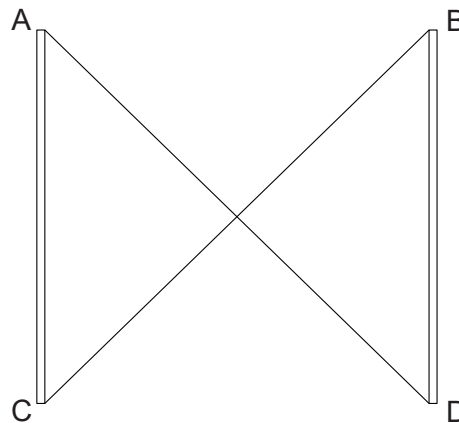

$AD = BC \quad AB = BD$

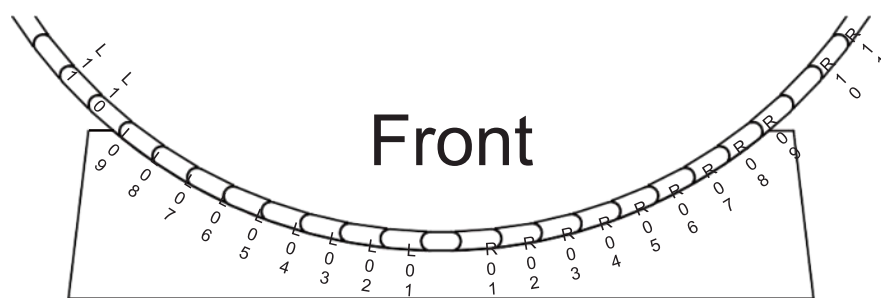

Fiecare șipcă este numerotată și etichetată.
Partea stângă este L01 L02 L03..... L38 de jos în sus;
Partea dreaptă este R01 R02 R03..... R38 de jos în sus.

Instrucțiuni de asamblare

Pasii asamblării

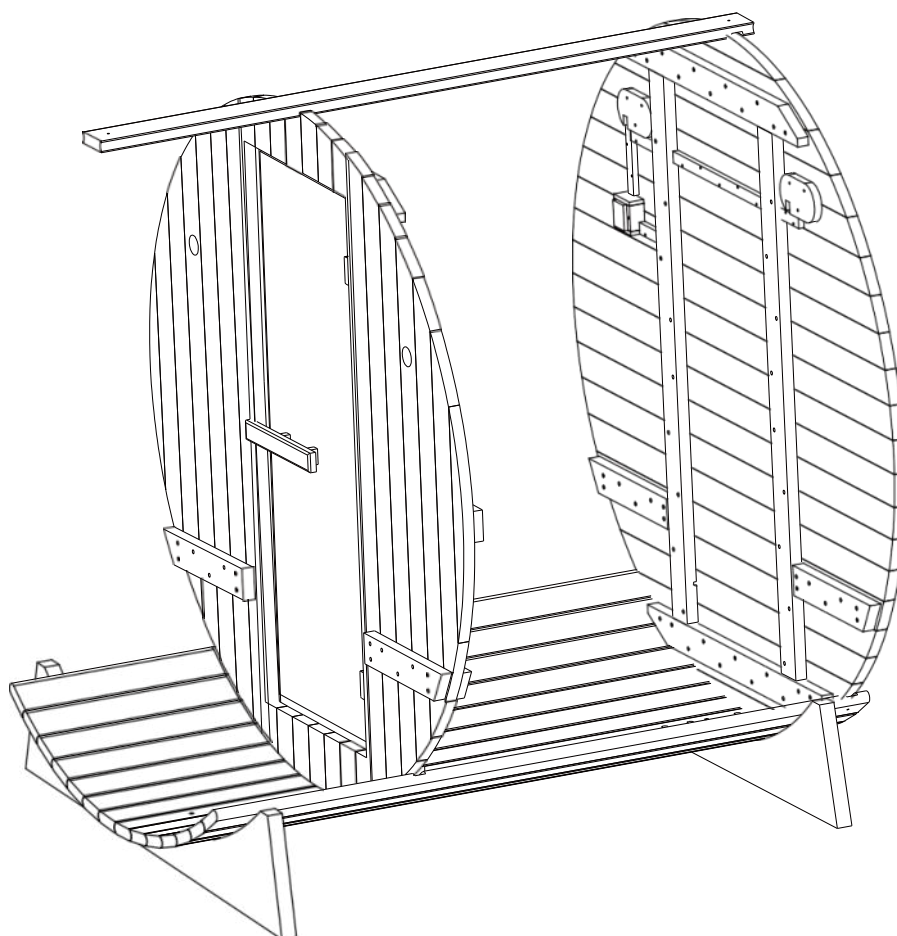
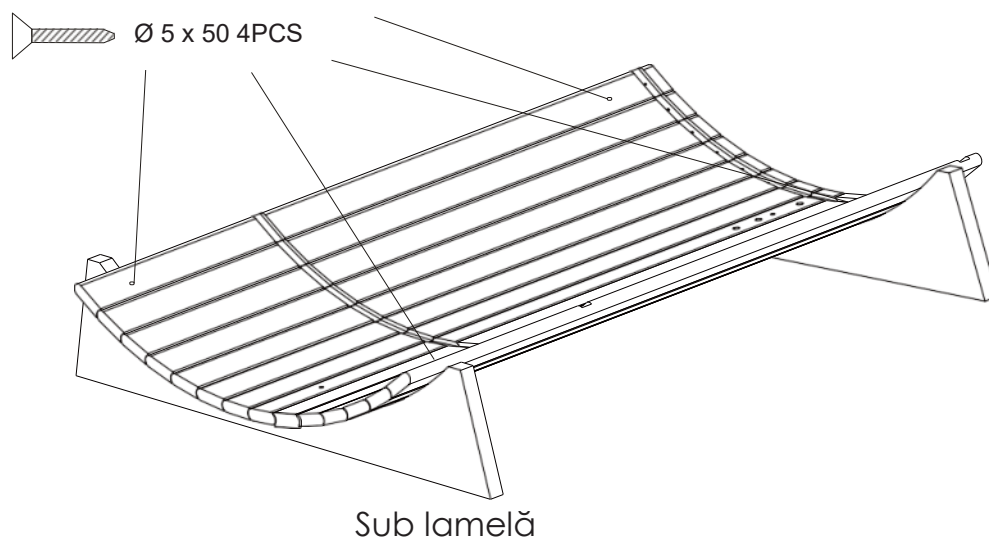

Sipca superioara trebuie instalata temporar ca măsură de protecție fixă în timpul instalării.

Instrucțiuni de asamblare

Pasii asamblării

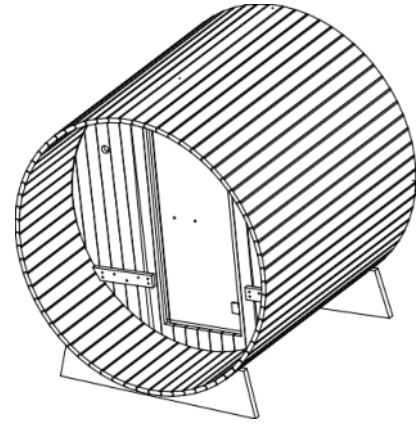
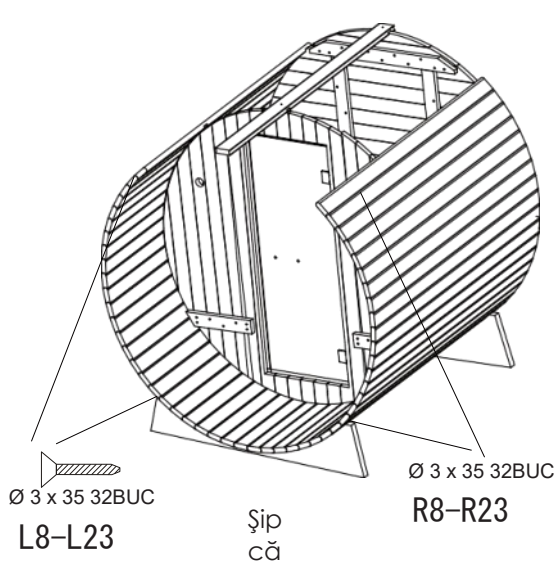

1. Lamelele corpului cilindrului, vă rugăm să fie așezate strâns la instalare, ceea ce favorizează instalarea superioară și etanșeitatea.
2. Șuruburile (M3 * 35 64PCS) sunt utilizate pentru fixarea lamelor L8-L23 și R8-R23, lamelele superioare sunt așezate strâns, după formarea unui cerc, cilindrul este fixat cu benzi din oțel inoxidabil.

În funcție de nevoile reale de instalare, una sau două plăci subțiri din mijloc pot fi îndepărtate după slăbirea șuruburilor.

plăci subțiri

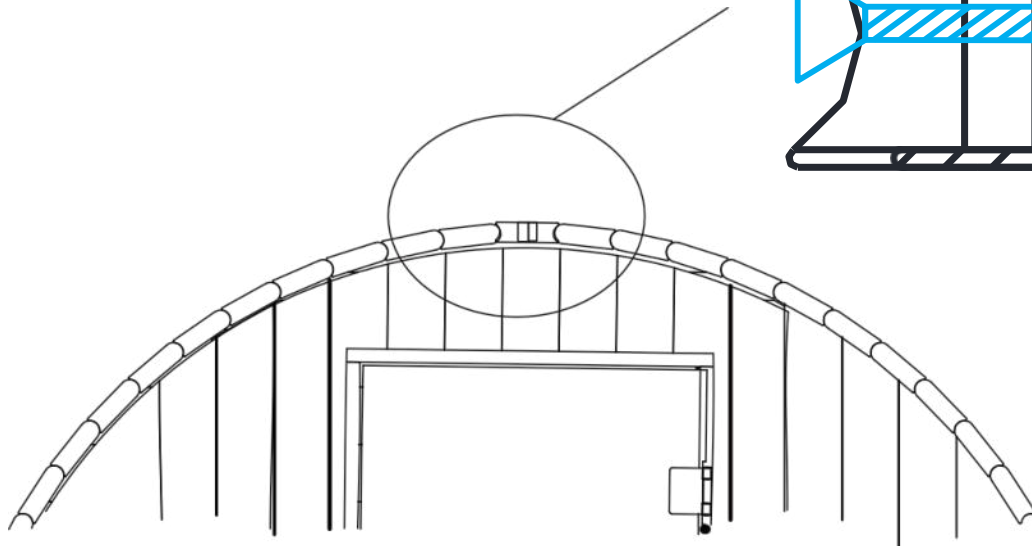
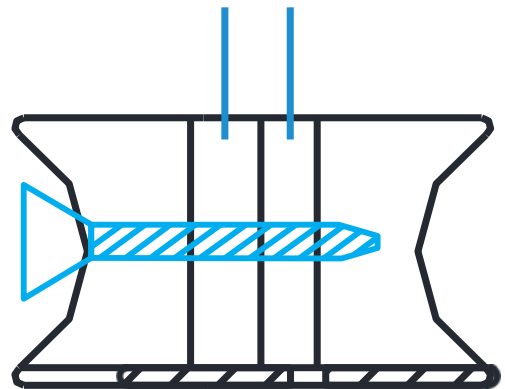

Instrucțiuni de asamblare

Pasii asamblarii

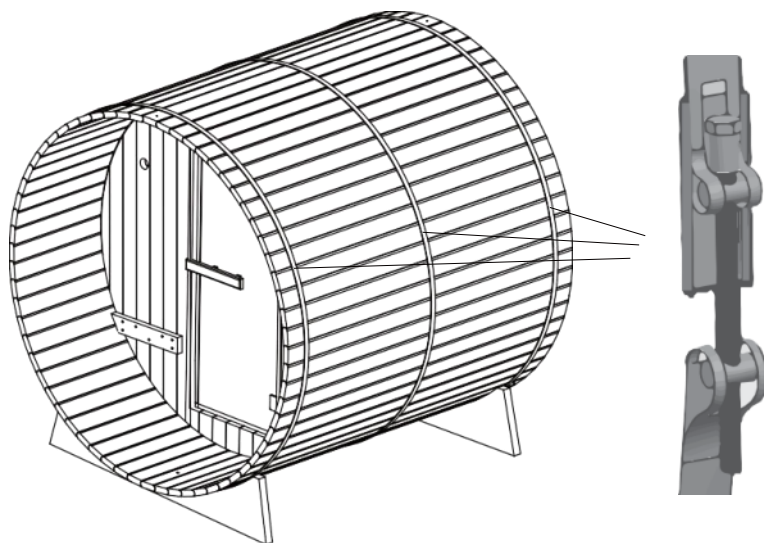

Benzi din oțel inoxidabil

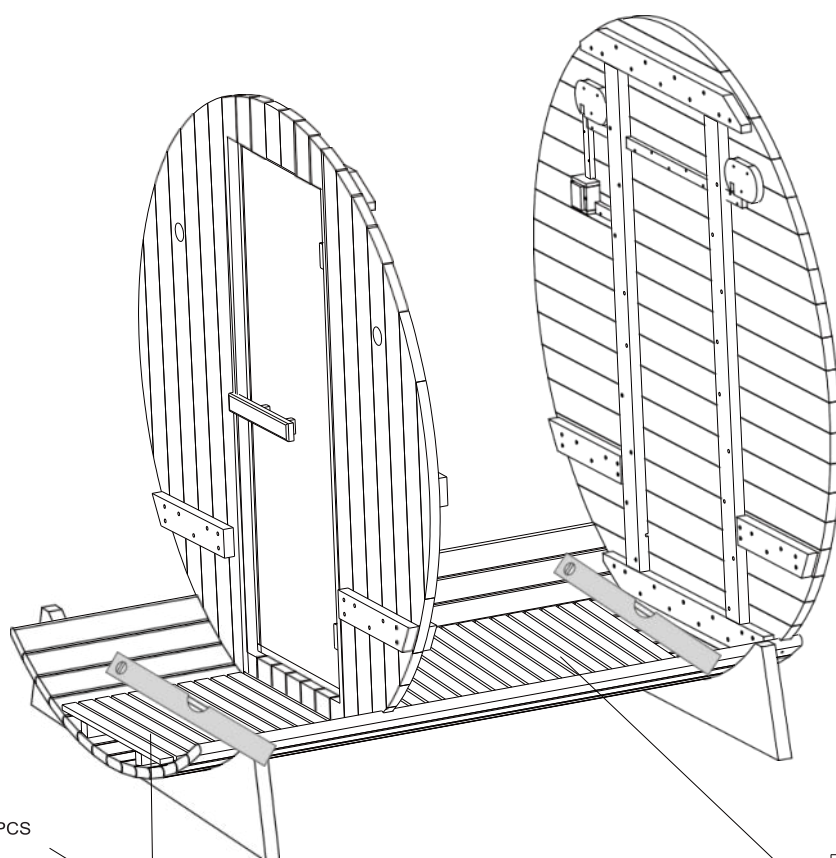

Ø 4 x 50 4PCS

Ø 4 x 50 4PCS

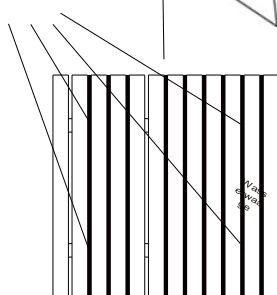

Wass
erwaag
ge

Podeau

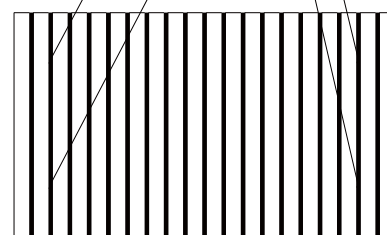

Instructiuni de asamblare

Pasii asamblarii

Suportul plăcilor scaunelor interioare și exterioare a fost preinstalate pe plăcile din față și din spate.

Placa de bază exterioară are nevoie de un alt cadru de susținere, iar cadrul de susținere se blochează cu șuruburile din imagine.

Placa de bază interioară nu are nevoie de un alt cadru de susținere.

Șuruburile de blocare a plăcii scaunului trebuie fixate pe partea de sprijin a plăcilor din față și din spate.

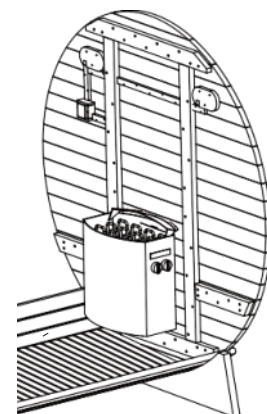
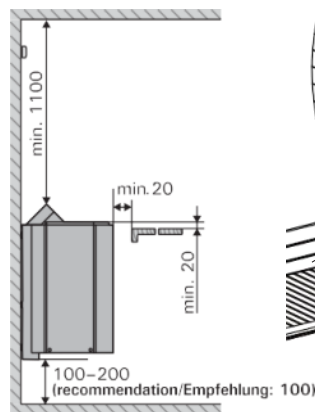
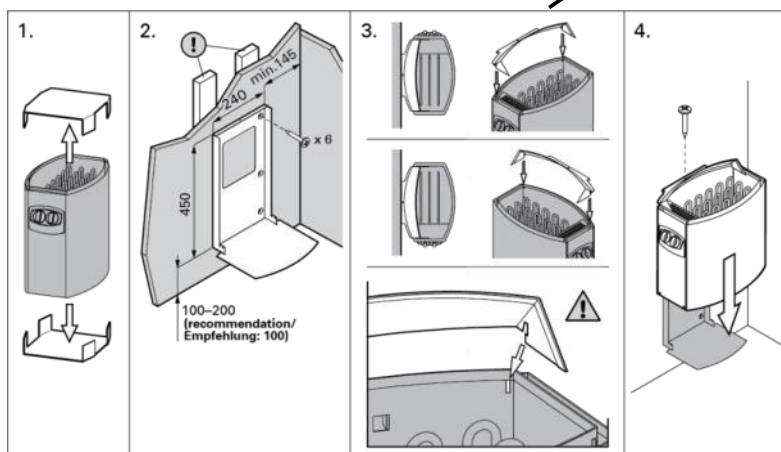
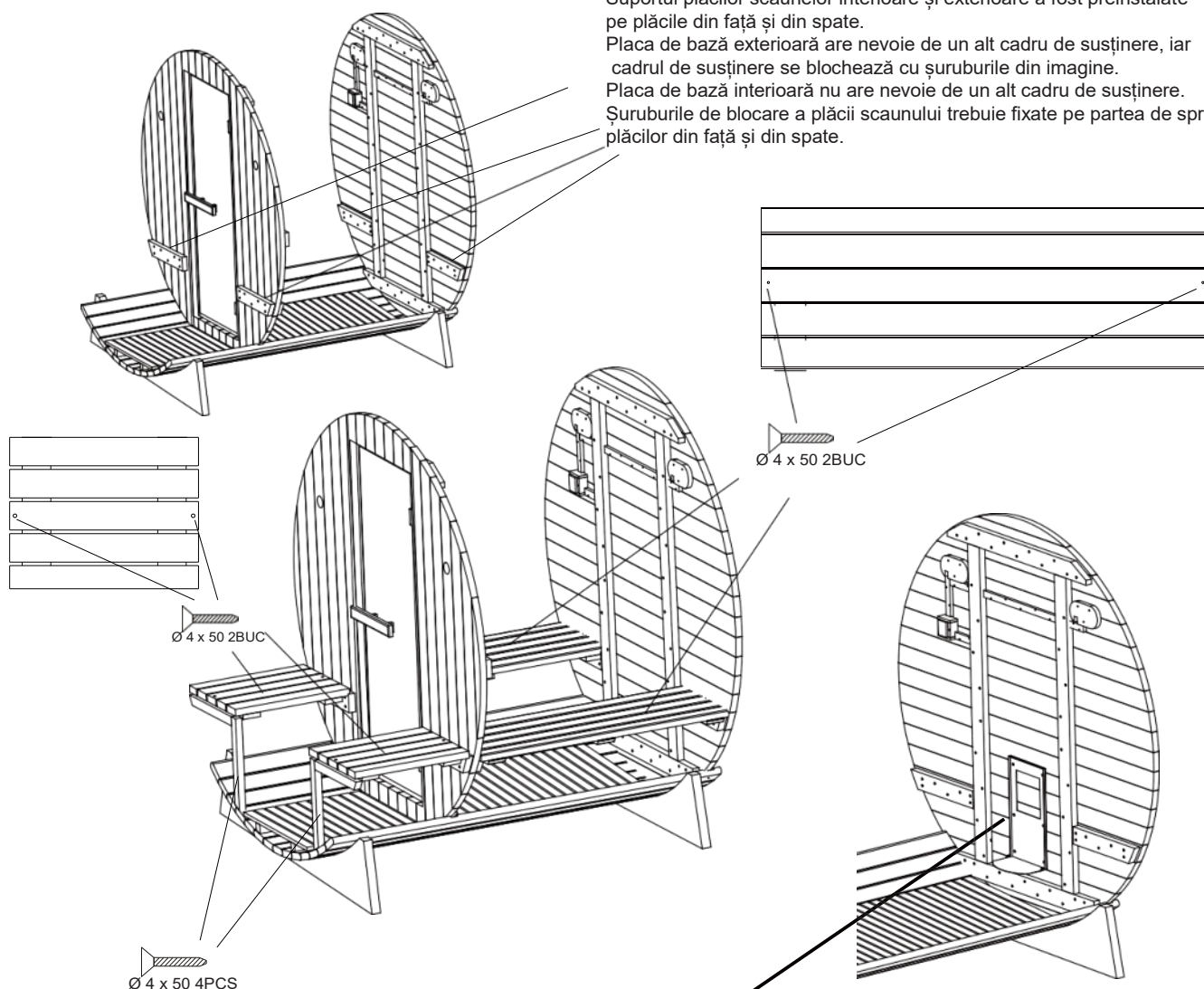

Instalarea sobei pentru sauna necesită mai întâi instalarea suportului de perete al acesteia. Vă rugăm să consultați diagrama pentru informații specifice.
Pentru informații mai detaliate, vă rugăm să citiți manualul furnizat împreună cu soba de saună.

Soba de saună are nevoie de un cablu universal conectat la o sursă de alimentare externă.
 Firele lămpii trebuie conectate la baza de cablare a sobei de saună și alimentate prin soba de saună.

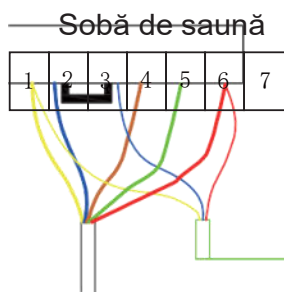
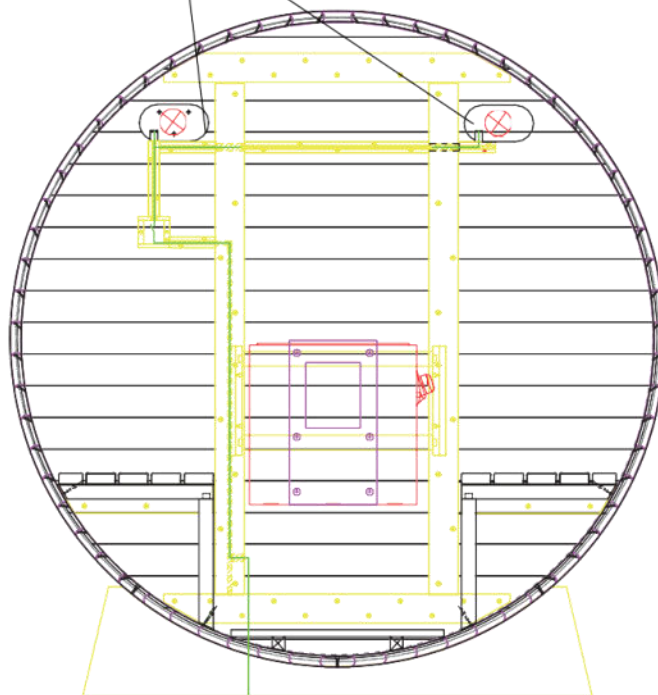
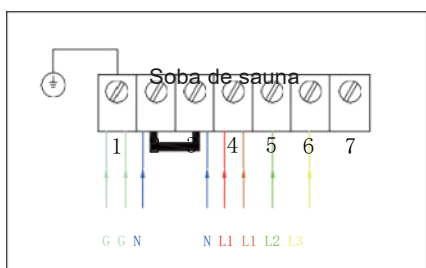
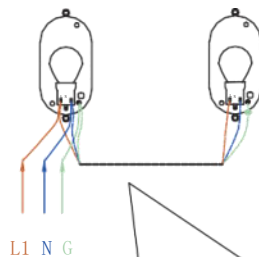

Cablu (5*2.5mm²)

Alimentare lampă (3 * 0.75mm²)

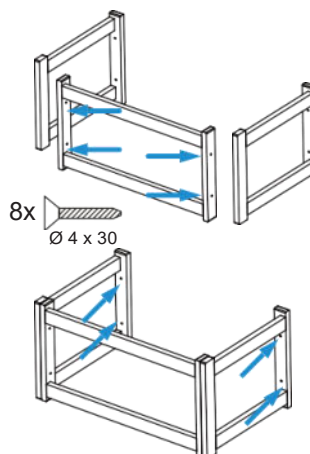
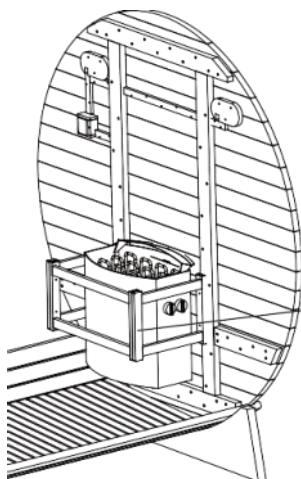

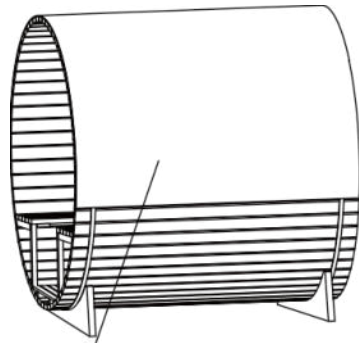

Pânză impermeabilă

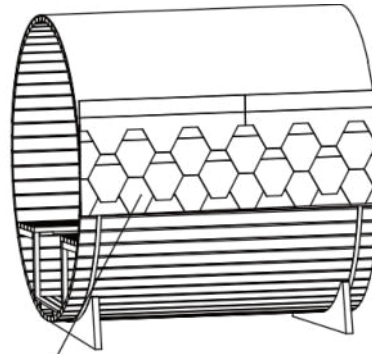

Șindrilă asfaltică



Ø 4 x 12 200BUC

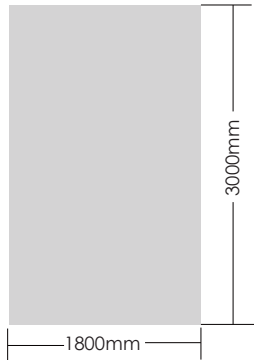

1800mm

3000mm

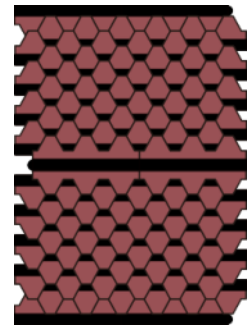
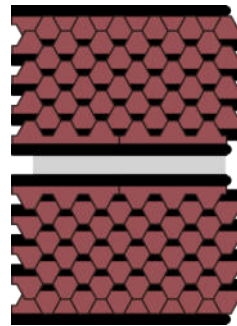
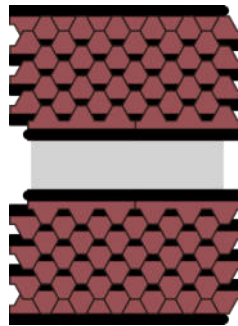
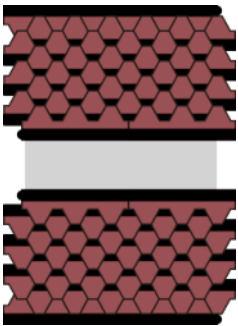
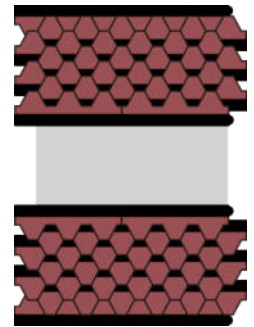
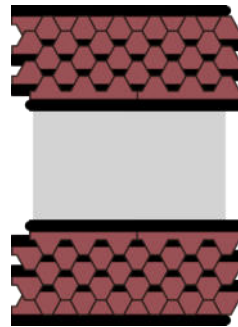
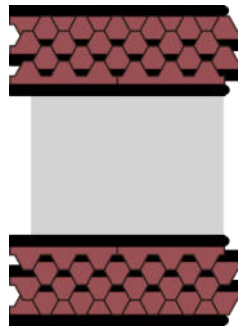
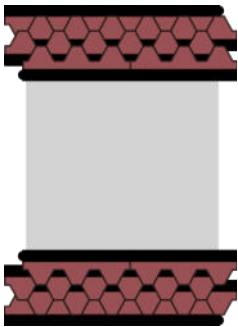
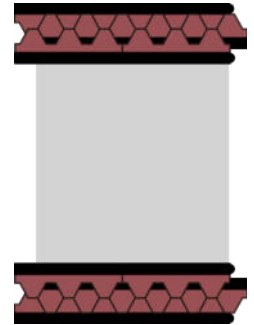
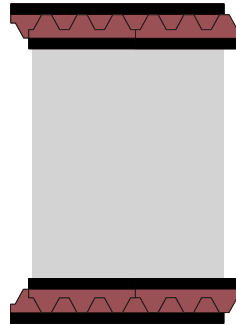

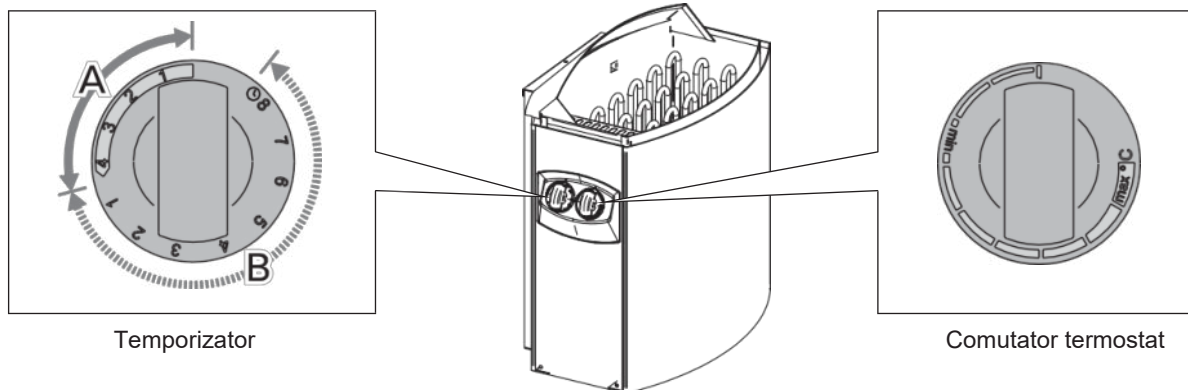

1. Încălzitor Pe

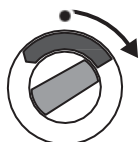

Rotiți comutatorul temporizatorului la secțiunea "pornit" (secțiunea A din figura 2, 0-4 ore). Încălzitorul începe încălzirea imediat.

2. Pre-setare Timp (pornire temporizată)



Rotiți comutatorul temporizatorului la secțiunea "pre-setare" (secțiunea B din figura 2, 0-8 ore). Încălzitorul începe să se încălzească atunci când cronometrul a întors comutatorul la secțiunea "pornit". După aceasta, încălzitorul va porni timp de aproximativ patru ore.

Pentru informații mai detaliate despre utilizarea specifică și precauțiile sobei de saună, vă rugăm să citiți manualul furnizat împreună cu soba de saună.

Întreținere

Protecția lemnului

Periați fiecare șipcă exterioară a butoiului și aplicați o soluție de protecție pentru lemn (ex. baie) atunci când asamblați complet pentru a proteja lemnul. Această protecție pentru lemn ar trebui reînnoită în conformitate cu recomandările produsului utilizat

Întreținere

IMPORTANT:

Deconectați cablul de alimentare al cabinei înainte de a efectua orice lucrare de întreținere.

Probleme identificate	Motive posibile	Soluții
Soba electrică nu se încălzește.	Cablul de alimentare este deconectat.	Verificați conexiunea cablului sursei de alimentare.
	Sursa de alimentare generală este întreruptă.	Verificați dacă tabloul de siguranțe și priza de perete funcționează.
	Soba este protejată la supraîncălzire.	Consultați manualul sobei electrice.
Corpurile de iluminat ale saunei nu mai funcționează.	Cablul de lumină nu este conectat.	Conectați cablul.
	Lumina este defectă.	Contactați distribuitorul.

Service

1. Deconectați sauna.
2. Utilizați un aspirator pentru a îndepărta praful din crăpăturile din tâmplărie.
3. Curățați cabina cu o cârpă umedă din bumbac și utilizați o cantitate mică de săpun, dacă este necesar. Clătiți cu o cârpă umedă.
4. Curățați geamul cu soluție de curățat sticla / geamuri și o carpa moale.
5. Mențineți exteriorul saunei tratat la fiecare 2 ani cu un produs adecvat.

IMPORTANT:

Lemnul trebuie tratat cu un produs de protecție numai în exteriorul saunei. Nu trebuie aplicat niciun tratament în interiorul saunei.

Nu utilizați benzen, alcool, agenți chimici sau detergenți puternici pe saună, deoarece produsele chimice pot deteriora lemnul.

Nu pulverizați apă pe interiorul saunei.

Vă rugăm să citiți instrucțiunile furnizate împreună cu soba de saună pentru instalarea și utilizarea sobei.

Încălzitorul poate fi conectat la rețeaua electrică numai în conformitate cu reglementările în vigoare de către un electrician profesionist autorizat.

BC45, BC60, BC80, BC90 BC45E, BC60E, BC80E, BC90E

EN Instructions for Installation and Use of Electric Sauna Heater

DE Gebrauchs- und Montageanleitung des Elektrosaunaofens



BC



BC-E

These instructions for installation and use are intended for the owner or the person in charge of the sauna, as well as for the electrician in charge of the electrical installation of the heater. After completing the installation, the person in charge of the installation should give these instructions to the owner of the sauna or to the person in charge of its operation. Please read the instructions for use carefully before using the heater.

The heater is designed for the heating of a sauna room to bathing temperature. It is not to be used for any other purpose.

Congratulations on your choice!

Guarantee:

- The guarantee period for heaters and control equipment used in saunas by families is two (2) years.
- The guarantee period for heaters and control equipment used in saunas by building residents is one (1) year.
- The guarantee does not cover any faults resulting from failure to comply with installation, use or maintenance instructions.
- The guarantee does not cover any faults resulting from the use of stones not recommended by the heater manufacturer.

CONTENTS

1. INSTRUCTIONS FOR USE	3
1.1. Piling of the Sauna Stones.....	3
1.1.1. Maintenance	3
1.2. Heating of the Sauna.....	4
1.3. Using the Heater	4
1.3.1. Heater On	4
1.3.2. Pre-setting Time (timed switch-on)	4
1.3.3. Heater Off.....	5
1.3.4. Setting the Temperature	5
1.4. Throwing Water on Heated Stones	5
1.5. Instructions for Bathing	6
1.6. Warnings	6
1.7. Troubleshooting	6
2. SAUNA ROOM	8
2.1. Sauna Room Structure	8
2.1.1. Blackening of the sauna walls.....	8
2.2. Sauna Room Ventilation.....	9
2.3. Heater Output.....	9
2.4. Sauna Room Hygiene.....	9
3. INSTRUCTIONS FOR INSTALLATION	10
3.1. Before Installation	10
3.2. Fastening the Heater on a Wall	11
3.3. Electrical Connections.....	12
3.3.1. Electric Heater Insulation Resistance.....	12
3.4. Installation of the Control Unit and Sensors (BC-E) ..	13
3.5. Resetting the Overheat Protector.....	13
4. SPARE PARTS	15

Diese Montage- und Gebrauchsanleitung richtet sich an den Besitzer der Sauna oder an die für die Pflege der Sauna verantwortliche Person, sowie an den für die Montage des Saunaofens zuständigen Elektromonteur. Wenn der Saunaofen montiert ist, wird diese Montage- und Gebrauchsanleitung an den Besitzer der Sauna oder die für die Pflege der Sauna verantwortliche Person übergeben. Lesen Sie vor Inbetriebnahme des Ofens die Bedienungsanleitung sorgfältig durch.

Der Ofen dient zum Erwärmen von Saunakabinen auf Saunatemperatur. Die Verwendung zu anderen Zwecken ist verboten.

Wir beglückwünschen Sie zu Ihrer guten Wahl!

Garantie:

- Die Garantiezeit für in Familiensaunen verwendete Saunaöfen und Steuergeräte beträgt zwei (2) Jahre.
- Die Garantiezeit für Saunaöfen und Steuergeräte, die in öffentlichen Saunen in Privatgebäuden verwendet werden, beträgt ein (1) Jahr.
- Die Garantie deckt keine Defekte ab, die durch fehlerhafte Installation und Verwendung oder Missachtung der Wartungsanweisungen entstanden sind.
- Die Garantie kommt nicht für Schäden auf, die durch Verwendung anderer als vom Werk empfohlener Saunaofensteine entstehen.

INHALT

1. BEDIENUNGSANLEITUNG	3
1.1. Aufschichten der Saunaofensteine.....	3
1.1.1. Wartung	3
1.2. Erhitzen der Saunakabine	4
1.3. Benutzung des Ofens.....	4
1.3.1. Ofen ein	4
1.3.2. Vorwahlzeit (zeitgesteuertes Einschalten)	4
1.3.3. Ofen aus.....	5
1.3.4. Einstellen der Temperatur.....	5
1.4. Aufguss	5
1.5. Anleitungen zum Saunen.....	6
1.6. Warnungen.....	6
1.7. Störungen	6
2. SAUNAKABINE	8
2.1. Struktur der Saunakabine	8
2.1.1. Schwärzung der Saunawände.....	8
2.2. Belüftung der Saunakabine	9
2.3. Leistungsabgabe des Ofens	9
2.4. Hygiene der Saunakabine	9
3. INSTALLATIONSANLEITUNG	10
3.1. Vor der Montage	10
3.2. Befestigung des Saunaofens an der Wand	11
3.3. Elektroanschlüsse.....	12
3.3.1. Isolationswiderstand des Elektrosaunaofens... ..	12
3.4. Anschluß des Steuergerätes und der Fühler (BC-E)..	13
3.5. Zurückstellen des Überhitzungsschutzes.....	13
4. ERSATZTEILE	15

1. INSTRUCTIONS FOR USE

1.1. Piling of the Sauna Stones

The piling of the sauna stones has a great effect on the functioning of the heater (figure 1).

Important information on sauna stones:

- The stones should be 5–10 cm in diameter.
- Use solely angular split-face sauna stones that are intended for use in a heater. Peridotite, olivine-dolerite and olivine are suitable stone types.
- **Neither light, porous ceramic "stones" nor soft soapstones should be used in the heater. They do not absorb enough heat when warmed up. This can result in damage in heating elements.**
- Wash off dust from the stones before piling them into the heater.

Please note when placing the stones:

- Do not drop stones into the heater.
- Do not wedge stones between the heating elements.
- Place the stones sparsely to ensure that air can circulate between them.
- Pile the stones so that they support each other instead of lying their weight on the heating elements.
- Do not form a high pile of stones on top of the heater.
- No such objects or devices should be placed inside the heater stone space or near the heater that could change the amount or direction of the air flowing through the heater.

1. BEDIENUNGSANLEITUNG

1.1. Aufschichten der Saunaofensteine

Die Schichtung der Ofensteine hat eine große Auswirkung auf die Effizienz des Ofens (Abb. 1).

Wichtige Informationen zu Saunaofensteinen:

- Die Steine sollten einen Durchmesser von 5–10 cm haben.
- Verwenden Sie nur spitze Saunasteine mit rauer Oberfläche, die für die Verwendung in Saunaöfen vorgesehen sind. Geeignete Gesteinsarten sind Peridotit, Olivin-Dolerit und Olivin.
- **Im Saunaofen sollten weder leichte poröse „Steine“ aus Keramik noch weiche Specksteine verwendet werden. Sie absorbieren beim Erhitzen nicht genügend Wärme, was zu einer Beschädigung der Heizelemente führen kann.**
- Die Steine sollten vor dem Aufschichten von Steinstaub befreit werden.

Beachten Sie beim Platzieren der Steine Folgendes:

- Lassen Sie die Steine nicht einfach in den Ofen fallen.
- Vermeiden Sie ein Verkeilen von Steinen zwischen den Heizelementen.
- Schichten Sie die Steine in lockerer Anordnung, so dass Luft zwischen ihnen hindurchströmen kann.
- Schichten Sie die Steine so aufeinander, dass sie nicht gegen die Heizelemente drücken.
- Schichten Sie die Steine oben auf dem Ofen nicht zu einem hohen Stapel auf.
- In der Steinkammer oder in der Nähe des Saunaofens dürfen sich keine Gegenstände oder Geräte befinden, die die Menge oder die Richtung des durch den Saunaofen führenden Luftstroms ändern.

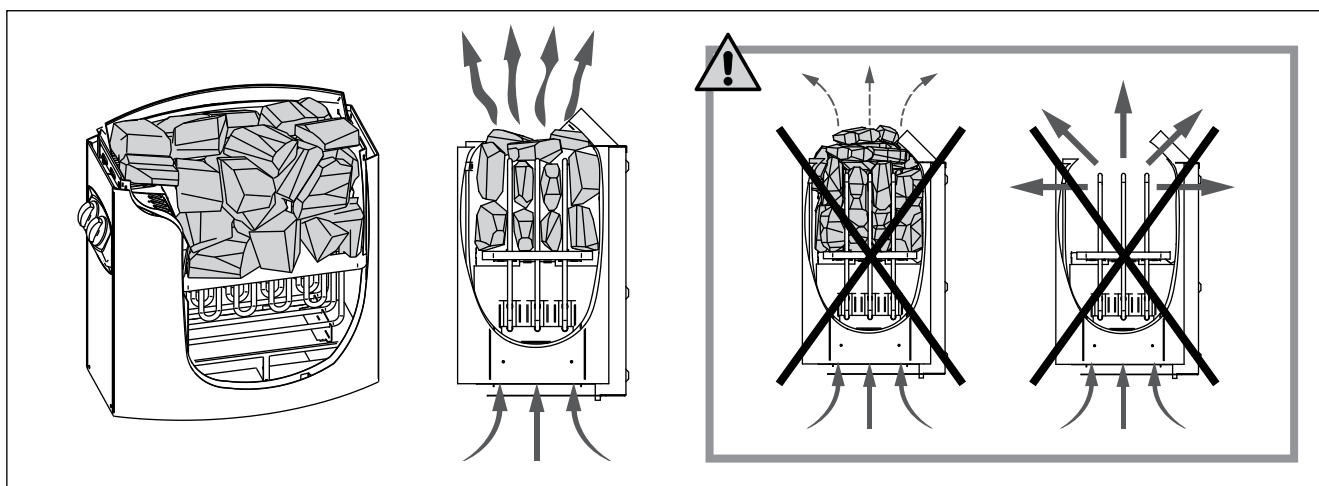

Figure 1. Piling of the sauna stones
Abbildung 1. Aufschichtung der Saunaofensteine

1.1.1. Maintenance

Due to large variation in temperature, the sauna stones disintegrate in use. Rearrange the stones at least once a year or even more often if the sauna is in frequent use. At the same time, remove any pieces of stones from the bottom of the heater and replace any disintegrated stones with new ones. By doing this, the heating capability of the heater stays optimal and the risk of overheating is avoided.

1.1.1. Wartung

Aufgrund der großen Wärmeänderungen werden die Saunasteine spröde und brüchig. Die Steine sollten mindestens einmal jährlich neu aufgeschichtet werden, bei regelmäßigem Gebrauch öfter. Bei dieser Gelegenheit entfernen Sie bitte auch Staub und Gesteinssplitter aus dem unteren Teil des Saunaofens und ersetzen beschädigte Steine. Hierdurch bleibt die Heizleistung des Ofens optimal, und das Risiko der Überhitzung wird vermieden.

1.2. Heating of the Sauna

When operating the heater for the first time, both the heater and the stones emit smell. To remove the smell, the sauna room needs to be efficiently ventilated.

If the heater output is suitable for the sauna room, it will take about an hour for a properly insulated sauna to reach the required bathing temperature (▷ 2.3.). The sauna stones normally reach the bathing temperature at the same time as the sauna room. A suitable temperature for the sauna room is about 65–80 °C.

1.3. Using the Heater

Before switching the heater on always check that there isn't anything on top of the heater or inside the given safety distance. ▷ 1.6.

- Heater models BC45, BC60, BC80 and BC90 are equipped with a timer and a thermostat. The timer is for setting the on-time for the heater and the thermostat is for setting a suitable temperature. ▷ 1.3.1.–1.3.4.
- Heater models BC45E, BC60E, BC80E and BC90E are controlled from a separate control unit. See the instructions for use of the selected control unit model.

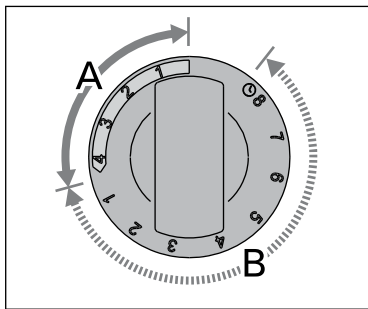

Figure 2. Timer switch
Abbildung 2. Schalter der Zeitschaltuhr

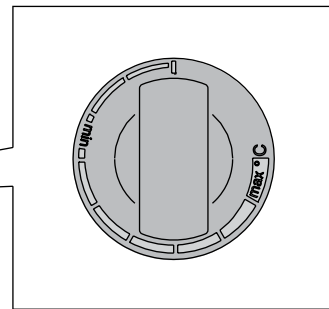
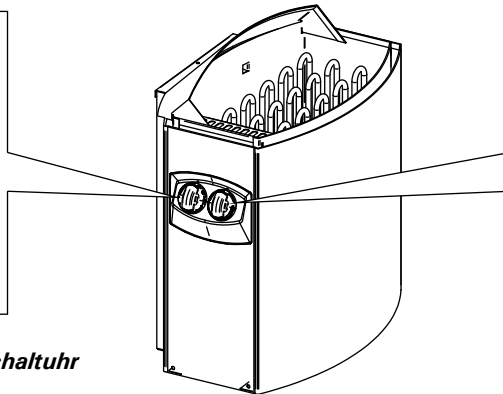
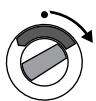

Figure 3. Thermostat switch
Abbildung 3. Thermostatschalter

1.3.1. Heater On



Turn the timer switch to the "on" section (section A in figure 2, 0–4 hours). The heater starts heating immediately.

1.3.2. Pre-setting Time (timed switch-on)



Turn the timer switch to the "pre-setting" section (section B in figure 2, 0–8 hours). The heater starts heating when the timer has turned the switch back to the "on" section. After this, the heater will be on for about four hours.

Example: You want to go walking for three hours and have a sauna bath after that. Turn the timer switch to the "pre-setting" section at number 2.

The timer starts. After two hours, the heater starts heating. Because it takes about one hour for the sauna to be heated, it will be ready for bathing after about three hours, that is, when you come back from your walk.

1.2. Erhitzen der Saunakabine

Beim ersten Erwärmen sondern sich von Saunaofen und Steinen Gerüche ab. Um diese zu beseitigen, muss die Saunakabine gründlich gelüftet werden.

Bei einer für die Saunakabine angemessenen Ofenleistung ist eine isolierte Sauna innerhalb von einer Stunde auf die erforderliche Saunatemperatur aufgeheizt (▷ 2.3.). Die Saunaofensteine erwärmen sich gewöhnlicherweise in derselben Zeit auf Aufgusstemperatur wie die Saunakabine. Die passende Temperatur in der Saunakabine beträgt etwa 65 bis 80 °C.

1.3. Benutzung des Ofens

Bitte überprüfen Sie, bevor Sie den Ofen anschalten, dass keine Gegenstände auf dem Ofen oder in unmittelbarer Nähe des Ofens liegen. ▷ 1.6.

- Die Ofenmodelle BC45, BC60, BC80 und BC90 sind mit einer Zeitschaltuhr und einem Thermostat ausgestattet. Die Zeitschaltuhr regelt die Einschaltzeit des Ofens und das Thermostat die Temperatur. ▷ 1.3.1.–1.3.4.
- Die Ofenmodelle BC45E, BC60E, BC80E und BC90E werden mit einem separaten Steuergerät bedient. Beachten Sie die mitgelieferte Bedienungsanleitung der Steuerung.

1.3.1. Ofen ein

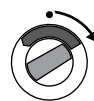

Stellen Sie den Schalter der Zeitschaltuhr in den Abschnitt "ein" (Abschnitt A in Abb. 2, 0–4 Stunden). Der Ofen beginnt sofort zu heizen.

1.3.2. Vorwahlzeit (zeitgesteuertes Einschalten)



Stellen Sie den Schalter der Zeitschaltuhr in den Abschnitt "Vorwahl" (Abschnitt B in Abb. 2, 0–8 Stunden). Der Ofen beginnt zu heizen, wenn die Zeitschaltuhr den Schalter zurück in den Abschnitt "ein" gedreht hat. Danach bleibt der Ofen etwa vier Stunden lang an.

Beispiel: Sie möchten drei Stunden lang spazieren gehen und danach ein Saunabad nehmen. Stellen Sie den Schalter der Zeitschaltuhr in den Abschnitt "Vorwahl" auf Nummer 2.

Die Zeitschaltuhr beginnt zu laufen. Nach zwei Stunden beginnt der Ofen zu heizen. Da es etwa eine Stunde dauert, bis die Sauna erhitzt ist, wird sie nach etwa drei Stunden für das Saunabad bereit sein, also dann, wenn Sie von Ihrem Spaziergang zurückkehren.

1.3.3. Heater Off



The heater switches off, when the timer turns the switch back to zero. You can switch the heater off at any time by turning the timer switch to zero yourself.

Switch the heater off after bathing. Sometimes it may be advisable to leave the heater on for a while to let the wooden parts of the sauna dry properly.

NOTE! Always check that the heater has switched off and stopped heating after the timer has turned the switch to zero.

1.3.4. Setting the Temperature

The purpose of the thermostat (figure 3) is to keep the temperature in the sauna room on a desired level. By experimenting, you can find the setting that suits you best.

Begin experimenting at the maximum position. If, during bathing, the temperature rises too high, turn the switch counter-clockwise a little. Note that even a small difference within the maximum section will change the temperature of the sauna considerably.

1.4. Throwing Water on Heated Stones

The air in the sauna room becomes dry when warmed up. Therefore, it is necessary to throw water on the heated stones to reach a suitable level of humidity in the sauna. The effect of heat and steam on people varies – by experimenting, you can find the levels of temperature and humidity that suit you best.

NOTE! The maximum volume of the ladle is 0.2 litres. If an excessive amount of water is poured on the stones, only part of it will evaporate and the rest may splash as boiling hot water on the bathers. Never throw water on the stones when there are people near the heater, because hot steam may burn their skin.

NOTE! The water to be thrown on the heated stones should meet the requirements of clean household water (table 1). Only special aromas designed for sauna water may be used. Follow the instructions given on the package.

1.3.3. Ofen aus



Der Ofen wird ausgeschaltet, wenn die Zeitschaltuhr den Schalter zurück auf null gedreht hat. Sie können den Ofen jederzeit selbst ausschalten, indem Sie den Schalter der Zeitschaltuhr auf null stellen.

Schalten Sie den Ofen nach dem Saunabad aus. Manchmal ist es ratsam, den Ofen noch eine Weile weiter laufen zu lassen, um die Holzteile der Sauna richtig trocknen zu lassen.

ACHTUNG! Vergewissern Sie sich stets, dass der Ofen ausgeschaltet ist und nicht mehr heizt, wenn die Zeitschaltuhr den Schalter zurück auf null gedreht hat.

1.3.4. Einstellen der Temperatur

Zweck des Thermostats (Abb. 3) ist es, die Temperatur in der Saunakabine auf der gewünschten Höhe zu halten. Durch Ausprobieren können Sie ermitteln, welche Einstellung für Sie am besten geeignet ist.

Beginnen Sie mit der höchsten Einstellung. Wenn die Temperatur während des Saunabades zu hoch ansteigt, drehen Sie den Schalter ein Stück gegen den Uhrzeigersinn. Beachten Sie, dass im oberen Temperaturbereich auch kleine Änderungen die Temperatur in der Sauna beträchtlich beeinflussen.

1.4. Aufguss

Die Saunaluft trocknet bei Erwärmung aus, daher sollte zur Erlangung einer angenehmen Luftfeuchtigkeit auf die heißen Steine des Saunaofens Wasser gegossen werden. Die Auswirkungen von Hitze und Dampf sind von Mensch zu Mensch unterschiedlich – durch Ausprobieren finden Sie die Temperatur- und Luftfeuchtigkeitswerte, die für Sie am besten geeignet sind.

ACHTUNG! Die Kapazität der Saunakelle sollte höchstens 0,2 l betragen. Auf die Steine sollten keine größeren Wassermengen auf einmal gegossen werden, da beim Verdampfen sonst kochend heißes Wasser auf die Badenden spritzen könnte. Achten Sie auch darauf, daß Sie kein Wasser auf die Steine gießen, wenn sich jemand in deren Nähe befindet. Der heiße Dampf könnte Brandwunden verursachen.

ACHTUNG! Als Aufgusswasser sollte nur Wasser verwendet werden, das die Qualitätsvorschriften für Haushaltswasser erfüllt (Tabelle 1). Im Aufgusswasser dürfen nur für diesen Zweck ausgewiesene Duftstoffe verwendet werden. Befolgen Sie die Anweisungen auf der Packung.

Water property Wassereigenschaft	Effect Wirkung	Recommendation Empfehlung
Humus concentration Humusgehalt	Colour, taste, precipitates Farbe, Geschmack, Ablagerungen	< 12 mg/l
Iron concentration Eisengehalt	Colour, odour, taste, precipitates Farbe, Geruch, Geschmack, Ablagerungen	< 0,2 mg/l
Hardness: most important substances are manganese (Mn) and lime, i.e. calcium (Ca). Wasserhärte: Die wichtigsten Stoffe sind Mangan (Mn) und Kalk, d.h. Kalzium (Ca).	Precipitates Ablagerungen	Mn: < 0,05 mg/l Ca: < 100 mg/l
Chlorinated water Gechlortes Wasser	Health risk Gesundheitsschädlich	Forbidden to use Darf nicht verwendet werden
Seawater Salzwasser	Rapid corrosion Rasche Korrosion	Forbidden to use Darf nicht verwendet werden

Table 1. Water quality requirements

Tabelle 1. Anforderungen an die Wasserqualität

1.5. Instructions for Bathing

- Begin by washing yourself.
- Stay in the sauna for as long as you feel comfortable.
- Forget all your troubles and relax.
- According to established sauna conventions, you must not disturb other bathers by speaking in a loud voice.
- Do not force other bathers from the sauna by throwing excessive amounts of water on the stones.
- Cool your skin down as necessary. If you are in good health, you can have a swim if a swimming place or pool is available.
- Wash yourself after bathing.
- Rest for a while and let your pulse go back to normal. Have a drink of fresh water or a soft drink to bring your fluid balance back to normal.

1.6. Warnings

- **Staying in the hot sauna for long periods of time makes the body temperature rise, which may be dangerous.**
- **Keep away from the heater when it is hot. The stones and outer surface of the heater may burn your skin.**
- **Keep children away from the heater.**
- **Do not let young, handicapped or ill people bathe in the sauna on their own.**
- **Consult your doctor about any health-related limitations to bathing.**
- **Consult your child welfare clinic about taking little babies to the sauna.**
- **Be very careful when moving in the sauna, as the platform and floors may be slippery.**
- **Never go to a hot sauna if you have taken alcohol, strong medicines or narcotics.**
- **Never sleep in a hot sauna.**
- **Sea air and a humid climate may corrode the metal surfaces of the heater.**
- **Do not hang clothes to dry in the sauna, as this may cause a risk of fire. Excessive moisture content may also cause damage to the electrical equipment.**

1.7. Troubleshooting

Note! All service operations must be done by professional maintenance personnel.

The heater does not heat.

- Check that the fuses to the heater are in good condition.
- Check that the connection cable is connected (▷ 3.3.).
- Turn the timer switch to the "on" section (▷ 1.3.1.).
- Turn the thermostat to a higher setting (▷ 1.3.4.).
- Check that the overheat protector has not gone off. The timer works but the heater does not heat. (▷ 3.5.)

The sauna room heats slowly. The water thrown on the sauna stones cools down the stones quickly.

- Check that the fuses to the heater are in good

1.5. Anleitungen zum Saunen

- Waschen Sie sich vor dem Saunen.
- Bleiben Sie in der Sauna, solange Sie es als angenehm empfinden.
- Vergessen Sie jeglichen Stress, und entspannen Sie sich.
- Zu guten Saunamanieren gehört, daß Sie Rücksicht auf die anderen Badenden nehmen, indem Sie diese nicht mit unnötig lärmigem Benehmen stören.
- Verjagen Sie die anderen auch nicht mit zu vielen Aufgüssen.
- Lassen Sie Ihre erhitzte Haut zwischendurch abkühlen. Falls Sie gesund sind, und die Möglichkeit dazu besteht, gehen Sie auch schwimmen.
- Waschen Sie sich nach dem Saunen.
- Ruhen Sie sich aus, bis Sie sich ausgeglichen fühlen. Trinken Sie klares Wasser oder einen Softdrink, um Ihren Flüssigkeitshaushalt zu stabilisieren.

1.6. Warnungen

- **Ein langer Aufenthalt in einer heißen Sauna führt zum Ansteigen der Körpertemperatur, was gefährlich sein kann.**
- **Achtung vor dem heißen Saunaofen. Die Steine sowie das Gehäuse werden sehr heiß und können die Haut verbrennen.**
- **Halten Sie Kinder vom Ofen fern.**
- **Kinder, Gehbehinderte, Kranke und Schwache dürfen in der Sauna nicht alleingelassen werden.**
- **Gesundheitliche Einschränkungen bezogen auf das Saunen müssen mit dem Arzt besprochen werden.**
- **Über das Saunen von Kleinkindern sollten Sie sich in der Mütterberatungsstelle beraten lassen.**
- **Gehen Sie nicht in die Sauna, wenn Sie unter dem Einfluß von Narkotika (Alkohol, Medikamenten, Drogen usw.) stehen.**
- **Schlafen Sie nie in einer erhitzten Sauna.**
- **Meer- und feuchtes Klima können die Metalloberflächen des Saunaofens rosten lassen.**
- **Benutzen Sie die Sauna wegen der Brandgefahr nicht zum Kleider- oder Wäschetrocknen, außerdem können die Elektrogeräte durch die hohe Feuchtigkeit beschädigt werden.**

1.7. Störungen

Achtung! Alle Wartungsmaßnahmen müssen von qualifiziertem technischem Personal durchgeführt werden.

Der Ofen wärmt nicht.

- Vergewissern Sie sich, dass die Sicherungen des Ofens in gutem Zustand sind.
- Überprüfen Sie, ob das Anschlusskabel eingesteckt ist (▷ 3.3.).
- Stellen Sie den Schalter der Zeitschaltuhr in den Abschnitt "ein" (▷ 1.3.1.).
- Stellen Sie das Thermostat auf eine höhere Einstellung (▷ 1.3.4.).
- Überprüfen Sie, ob der Überhitzungsschutz ausgelöst wurde. Die Zeitschaltuhr läuft, aber der Ofen wärmt nicht. (▷ 3.5.)

Die Saunakabine erhitzt sich zu langsam. Das auf die Saunaofensteine geworfene Wasser kühlt die Steine schnell ab.

condition.

- Check that all heating elements glow when the heater is on.
- Turn the thermostat to a higher setting (▷ 1.3.4.).
- Check that the heater output is sufficient (▷ 2.3.).
- Check the sauna stones (▷ 1.1.). Too tightly piled stones, the settling of stones with time or wrong stone type can hinder the air flow through the heater, which results in reduced heating efficiency.
- Check that the sauna room ventilation has been arranged correctly (▷ 2.2.).

The sauna room heats quickly, but the temperature of the stones remain insufficient.

Water thrown on the stones runs through.

- Turn the thermostat to a lower setting (▷ 1.3.4.).
- Check that the heater output is not too high (▷ 2.3.).
- Check that the sauna room ventilation has been arranged correctly (▷ 2.2.).

The sauna room heats unevenly.

- Check that the heater has been installed in the correct height. The heater heats the sauna best, when it is installed 100 mm from the floor. The maximum installation height is 200 mm. (▷ 3.2.)

Panel or other material near the heater blackens quickly.

- Check that the requirements for safety distances are fulfilled (▷ 3.1.).
- Check the sauna stones (▷ 1.1.). Too tightly piled stones, the settling of stones with time or wrong stone type can hinder the air flow through the heater, which may result in overheating of surrounding materials.
- Also see section 2.1.1.

The heater emits smell.

- See section 1.2.
- The hot heater may emphasize odours mixed in the air that are not, however, caused by the sauna or the heater. Examples: paint, glue, oil, seasoning.

The heater makes noise.

- BC: The timer is a mechanical device and it makes a ticking sound when it is functioning normally. If the timer ticks even when the heater is switched off, check the timer's wiring.
- Occasional bangs are most likely caused by stones cracking due to heat.
- The thermal expansion of heater parts can cause noises when the heater warms up.

- Vergewissern Sie sich, dass die Sicherungen des Ofens in gutem Zustand sind.
- Vergewissern Sie sich, dass bei eingeschaltetem Ofen alle Heizelemente glühen.
- Stellen Sie das Thermostat auf eine höhere Einstellung (▷ 1.3.4.).
- Überprüfen Sie, ob die Ofenleistung ausreichend ist (▷ 2.3.).
- Überprüfen Sie die Saunaofensteine (▷ 1.1.). Eine zu feste Stapelung der Steine, das Absetzen der Steine mit der Zeit und falsche Steinsorten können den Luftstrom durch den Ofen behindern, was zu einer verminderten Heizleistung führt.
- Vergewissern Sie sich, dass die Belüftung der Saunakabine korrekt eingerichtet wurde (▷ 2.2.).

Die Saunakabine erwärmt sich schnell, aber die Temperatur der Steine ist unzureichend. Das auf die Steine geworfene Wasser läuft durch.

- Stellen Sie das Thermostat auf eine niedrigere Einstellung (▷ 1.3.4.).
- Überprüfen Sie, ob die Ofenleistung nicht zu hoch ist (▷ 2.3.).
- Vergewissern Sie sich, dass die Belüftung der Saunakabine korrekt eingerichtet wurde (▷ 2.2.).

Die Saunakabine erhitzt sich ungleichmäßig.

- Vergewissern Sie sich, dass der Ofen in der richtigen Höhe angebracht wurde. Der Ofen kann die Sauna am besten erhitzen, wenn er 100 mm über dem Boden angebracht wird. Die maximale Montagehöhe beträgt 200 mm. (▷ 3.2.)

Panele und andere Materialien neben dem Ofen werden schnell schwarz.

- Überprüfen Sie, ob die Anforderungen für Sicherheitsabstände eingehalten werden (▷ 3.1.).
- Überprüfen Sie die Saunaofensteine (▷ 1.1.). Eine zu feste Stapelung der Steine, das Absetzen der Steine mit der Zeit und falsche Steinsorten können den Luftstrom durch den Ofen behindern, was zu einer Überhitzung der umliegenden Materialien führen kann.
- Siehe auch Abschnitt 2.1.1.

Der Ofen gibt Gerüche ab.

- Siehe Abschnitt 1.2.
- Ein heißer Ofen kann Gerüche in der Luft verstärken, die jedoch nicht durch die Sauna oder den Ofen selbst verursacht wurden. Beispiele: Farbe, Klebstoff, Öl, Würzmittel.

Der Ofen verursacht Geräusche.

- BC: Die Zeitschaltuhr ist ein mechanisches Gerät und verursacht daher ein tickendes Geräusch, wenn sie normal funktioniert. Ertönt das Ticken, obwohl der Ofen nicht eingeschaltet ist, untersuchen Sie die Anschlüsse der Zeitschaltuhr.
- Plötzliche Knall-Geräusche entstehen manchmal durch Steine, die aufgrund der Hitze platzen.
- Die Ausdehnung der Ofenteile wegen der Hitze kann bei der Erwärmung des Ofens Geräusche verursachen.

2. SAUNA ROOM

2.1. Sauna Room Structure

2. SAUNAKABINE

2.1. Struktur der Saunakabine

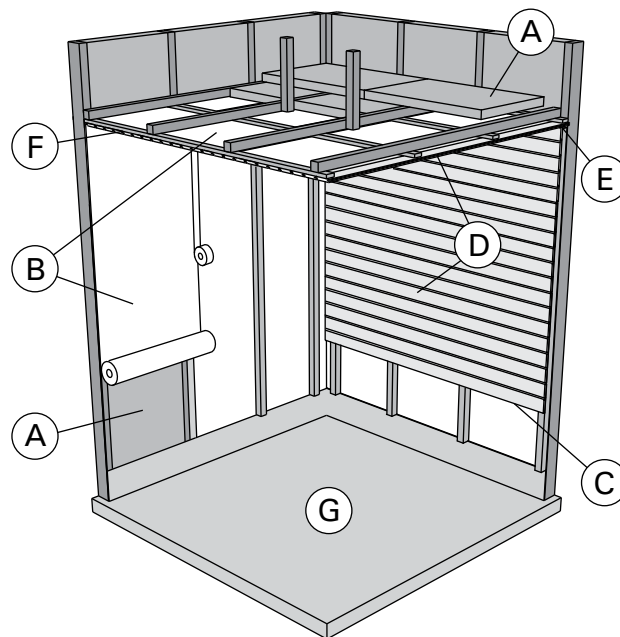

Figure 4.
Abbildung 4.

- A. Insulation wool, thickness 50–100 mm. The sauna room must be insulated carefully so that the heater output can be kept moderately low.
- B. Moisture protection, e.g. aluminium paper. Place the glossy side of the paper towards the sauna. Tape the seams with aluminium tape.
- C. Vent gap of about 10 mm between the moisture protection and panel (recommendation).
- D. Low mass 12–16 mm thick panel board. Before starting the panelling, check the electric wiring and the reinforcements in the walls required by the heater and benches.
- E. Vent gap of about 3 mm between the wall and ceiling panel.
- F. The height of the sauna is usually 2100–2300 mm. The minimum height depends on the heater (see table 2). The space between the upper bench and ceiling should not exceed 1200 mm.
- G. Use floor coverings made of ceramic materials and dark joint grouts. Particles disintegrating from the sauna stones and impurities in the sauna water may stain and/or damage sensitive floor coverings.

NOTE! Check from the fire authorities which parts of the firewall can be insulated. Flues which are in use must not be insulated.

NOTE! Light protective covers which are installed directly to the wall or ceiling may be a fire risk.

2.1.1. Blackening of the sauna walls

It is perfectly normal for the wooden surfaces of the sauna room to blacken in time. The blackening may be accelerated by

- sunlight
- heat from the heater
- protective agents on the walls (protective agents have a poor heat resistance level)
- fine particles disintegrating from the sauna stones which rise with the air flow.

- A. Isolierwolle, Stärke 50–100 mm. Die Saunakabine muss sorgfältig isoliert werden, damit der Ofen nicht zu viel Leistung erbringen muss.
- B. Feuchtigkeitsschutz, z.B. Aluminiumpapier. Die glänzende Seite des Papiers muss zur Sauna zeigen. Nähte mit Aluminiumband abdichten.
- C. Etwa 10 mm Luft zwischen Feuchtigkeitsschutz und Täfelung (Empfehlung).
- D. Leichtes, 12–16 mm starkes Täfelbrett. Vor Beginn der Täfelung elektrische Verkabelung und für Ofen und Bänke benötigte Verstärkungen in den Wänden überprüfen.
- E. Etwa 3 mm Luft zwischen Wand und Deckentäfelung.
- F. Die Höhe der Sauna ist normalerweise 2100–2300 mm. Die Mindesthöhe hängt vom Ofen ab (siehe Tabelle 2). Der Abstand zwischen oberer Bank und Decke sollte höchstens 1200 mm betragen.
- G. Bodenabdeckungen aus Keramik und dunkle Zementschlämme verwenden. Aus den Saunasteinen entweichende Partikel und Verunreinigungen im Wasser können sensible Böden verfärben oder beschädigen.

ACHTUNG! Fragen Sie die Behörden, welcher Teil der feuerfesten Wand isoliert werden kann. Rauchfänge, die benutzt werden, dürfen nicht isoliert werden.

ACHTUNG! Leichte, direkt an Wand oder Decke angebrachte Schutzabdeckungen sind ein Brandrisiko.

2.1.1. Schwärzung der Saunawände

Es ist ganz normal, wenn sich die Holzoberflächen einer Sauna mit der Zeit verfärben. Die Schwärzung wird beschleunigt durch

- Sonnenlicht
- Hitze des Ofens
- Täfelungsschutz an den Wänden (mit geringem Hitzewiderstand)
- Feinpartikel, die aus den zerfallenden Saunasteinen in die Luft entweichen.

2.2. Sauna Room Ventilation

The air in the sauna room should change six times per hour. Figure 5 illustrates different sauna room ventilation options.

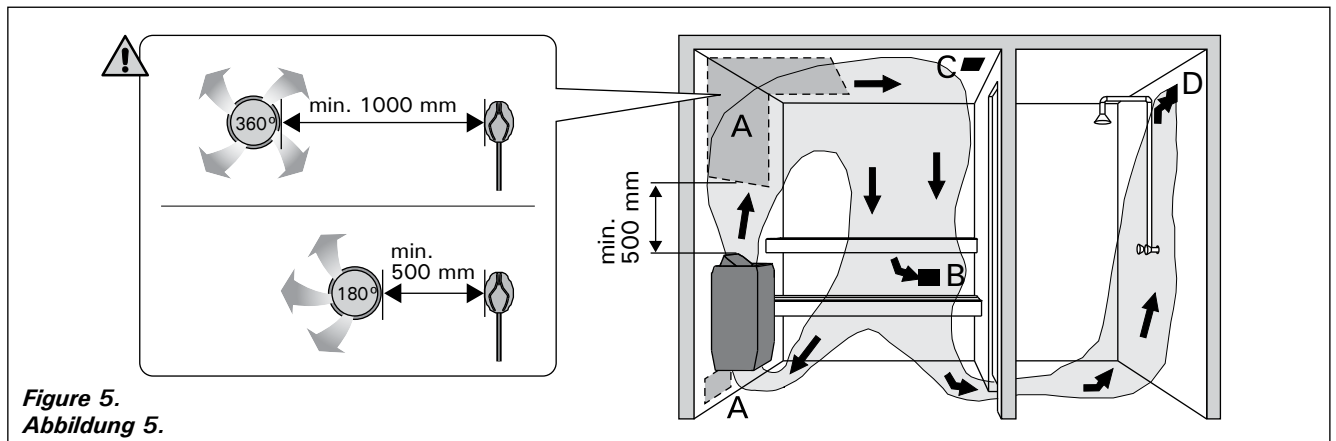

Figure 5.
Abbildung 5.

- A. Supply air vent location. If mechanical exhaust ventilation is used, place the supply air vent above the heater. If gravity exhaust ventilation is used, place the supply air vent below or next to the heater. The diameter of the supply air pipe must be 50–100 mm. **BC-E: Do not place the supply air vent so that the air flow cools the temperature sensor (see the temperature sensor installation instructions in the control unit installation instructions)!**
- B. Exhaust air vent. Place the exhaust air vent near the floor, as far away from the heater as possible. The diameter of the exhaust air pipe should be twice the diameter of the supply air pipe.
- C. Optional vent for drying (closed during heating and bathing). The sauna can also be dried by leaving the door open after bathing.
- D. If the exhaust air vent is in the washroom, the gap underneath the sauna door must be at least 100 mm. Mechanical exhaust ventilation is mandatory.

2.3. Heater Output

When the walls and ceiling are covered with panels and insulation behind the panels is adequate, the heater output is defined according to the volume of the sauna. Non-insulated walls (brick, glass block, glass, concrete, tile, etc.) increase the need for heater output. Add 1,2 m³ to the volume of the sauna for each non-insulated wall square meter. For example, a 10 m³ sauna room with a glass door equals the output requirement of about a 12 m³ sauna room. If the sauna room has log walls, multiply the sauna's volume by 1,5. Choose the correct heater output from table 2.

2.4. Sauna Room Hygiene

Bench towels should be used during bathing to prevent sweat from getting onto the benches.

The benches, walls and floor of the sauna should be washed thoroughly at least every six months. Use a scrubbing brush and sauna detergent.

Wipe dust and dirt from the heater with a damp cloth. Remove lime stains from the heater using a 10% citric acid solution and rinse.

2.2. Belüftung der Saunakabine

Die Saunaluft sollte sechsmal pro Stunde ausgetauscht werden. Abb. 5 zeigt verschiedene Optionen der Saunabelüftung.

- A. Luftzufuhr. Bei mechanischer Entlüftung Luftzufuhr über dem Ofen anbringen. Bei Schwerkraftentlüftung Luftzufuhr unter oder neben dem Ofen anbringen. Der Durchmesser des Luftzufuhrrohres muss 50–100 mm betragen. **BC-E: Luftzufuhr nicht so anbringen, dass sie den Temperaturfühler abkühlt (zur Anbringung des Temperaturfühlers siehe Installationsanweisungen des Steuergeräts)!**
- B. Entlüftung. Entlüftung in Bodennähe anbringen, so weit weg vom Ofen wie möglich. Der Durchmesser des Entlüftungsröhres sollte doppelt so groß sein wie bei der Luftzufuhr.
- C. Optionale Lüftung zum Trocknen (während Heizung und Bad geschlossen). Die Sauna kann auch durch die offene Tür getrocknet werden.
- D. Wenn die Entlüftung im Waschraum liegt, muss die Lücke unter der Saunatur mindestens 100 mm betragen. Mechanische Entlüftung ist Pflicht.

2.3. Leistungsabgabe des Ofens

Wenn Wand und Decke vertäfelt und ausreichend isoliert sind, richtet sich die Leistungsabgabe des Ofens nach dem Volumen der Sauna. Nicht isolierte Wände (Stein, Glasbausteine, Glas, Beton, Kacheln) erhöhen die benötigte Ofenleistung. Jeder Quadratmeter nicht isolierter Wand entspricht 1,2 m³ mehr Saunavolumen. Eine 10 m³ große Saunakabine mit Glastür z.B. entspricht in der Leistungsabgabe einer 12 m³ großen Sauna. Bei Balkenwänden Saunavolumen mit 1,5 multiplizieren. Korrekte Leistungsabgabe des Ofens aus Tabelle 2 wählen.

2.4. Hygiene der Saunakabine

Liegetücher benutzen, um die Bänke vor Schweiß zu schützen.

Bänke, Wände und Boden der Sauna mindestens alle sechs Monate waschen. Bürste und Saunareinigungsmittel verwenden.

Staub und Schmutz vom Ofen mit feuchtem Tuch abwischen. Kalkablagerungen am Ofen mit 10 % Zitronensäure entfernen und spülen.

3. INSTRUCTIONS FOR INSTALLATION

3.1. Before Installation

Before installing the heater, study the instructions for installation. Check the following points:

- Is the output and type of the heater suitable for the sauna room? **The cubic volumes given in table 2 should be followed.**
- Is the supply voltage suitable for the heater?
- The location of the heater fulfils the minimum requirements concerning safety distances given in fig. 6 and table 2.

It is absolutely necessary to install the heater according to these values. Neglecting them causes a risk of fire. Only one electrical heater may be installed in the sauna room.

3. INSTALLATIONSANLEITUNG

3.1. Vor der Montage

Bevor Sie den Saunaofen installieren, lesen Sie die Montageanleitung und überprüfen Sie folgende Dinge:

- Ist der zu montierende Saunaofen in Leistung und Typ passend für die Saunakabine? **Die Rauminhaltswerte in Tabelle 2 dürfen weder über noch unterschritten werden.**
- Ist die Netzspannung für den Saunaofen geeignet?
- Der Montageort des Ofens erfüllt die in Abbildung 6 und Tabelle 2 angegebenen Sicherheitsmindestabstände.

Diese Abstände müssen unbedingt eingehalten werden, da ein Abweichen Brandgefahr verursacht. In einer Sauna darf nur ein Saunaofen installiert werden.

Heater Ofen	Output Leistung	Sauna room Saunakabine			Electrical connections Elektroanschlüsse					
		Cubic vol. Rauminhalt		Height Höhe	400 V 3N~		230 V 1N~		To sensor (BC-E) An Fühler (BC-E)	
Model and dimensions/ Modell und Maße		min. m ³	max. m ³	min. mm	Connecting cable Anschlusskabel	Fuse Sicherung	Connecting cable Anschlusskabel	Fuse Sicherung		
Width/Breite • BC 480 mm • BC-E 450 mm Depth/Tiefe 310 mm Height/Höhe 540 mm Weight/Gewicht 11 kg Stones/Steine max. 20 kg	kW	> 2.3.				See fig. 8. The measurements apply to the connecting cable only! Siehe Abbildung 8. Die Messungen beziehen sich ausschließlich auf das Anschlusskabel!				
					mm ²	A	mm ²	A	mm ²	
BC45/BC45E	4,5	3	6	1900	5 x 1,5	3 x 10	3 x 2,5	1 x 20	4 x 0,25	
BC60/BC60E	6,0	5	8	1900	5 x 1,5	3 x 10	3 x 2,5	1 x 35	4 x 0,25	
BC80/BC80E	8,0	7	12	1900	5 x 2,5	3 x 16	3 x 6	1 x 35	4 x 0,25	
BC90/BC90E	9,0	8	14	1900	5 x 2,5	3 x 16	3 x 10	1 x 50	4 x 0,25	

Table 2. Installation details

Tabelle 2. Montageinformationen

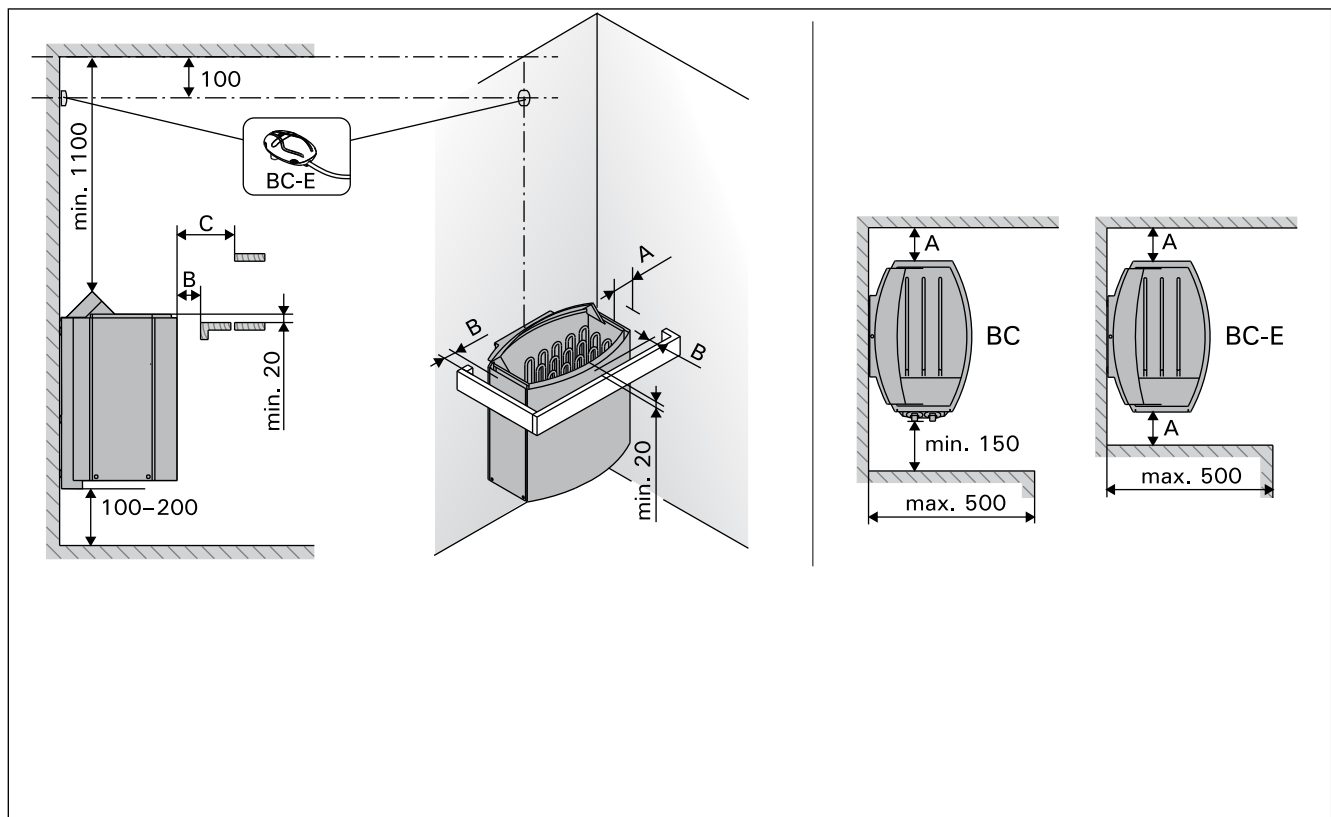

Figure 6. Safety distances (all dimensions in millimeters)

Abbildung 6. Sicherheitsmindestabstände (alle Abmessungen in Millimetern)

3.2. Fastening the Heater on a Wall

See figure 7.

1. Remove both cardboard covers before installation.
2. Fasten the wall-mounting rack on the wall by using the screws which come with the rack.
NOTE! There must be a support, e.g. a board, behind the panel, so that the fastening screws can be screwed into a thicker wooden material than the panel. If there are no boards behind the panel, the boards can also be fastened on the panel.
3. The right- or left-handedness of the heater can be changed by installing it to the rack correspondingly. Make sure the clip fastens in the hole properly.
4. Lift the heater to the rack on the wall so that the fastening hooks of the lower part of the rack go behind the edge of the heater body. Lock the edge of the heater onto the rack by a screw.

3.2. Befestigung des Saunaofens an der Wand

Siehe Abbildung 7.

1. Beide Schutzplatten vor der Montage entfernen!
2. Befestigen Sie das Montagegestell mit den dazu gelieferten Schrauben an der Wand.
ACHTUNG! An den Stellen, an denen die Befestigungsschrauben angebracht werden, muss sich hinter den Paneelen als Stütze z.B. ein Brett befinden, in dem die Schrauben fest sitzen. Falls sich hinter den Paneelen keine Bretter befinden, können diese auch vor den Paneelen angebracht werden.
3. Der Saunaofen kann zur Bedienung durch Rechts- oder Linkshänder unterschiedlich an der Wand montiert werden. Versichere, dass die Befestigungs-Ösen richtig dafür vorgesehene Aufhängung sitzen.
4. Heben Sie den Saunaofen so auf das Gestell an der Wand, daß die Befestigungshaken unten am Gestell hinter den Rand des Saunaofenrumpfes kommen. Schrauben Sie den oberen Rand des Saunaofens am Montagegestell fest.

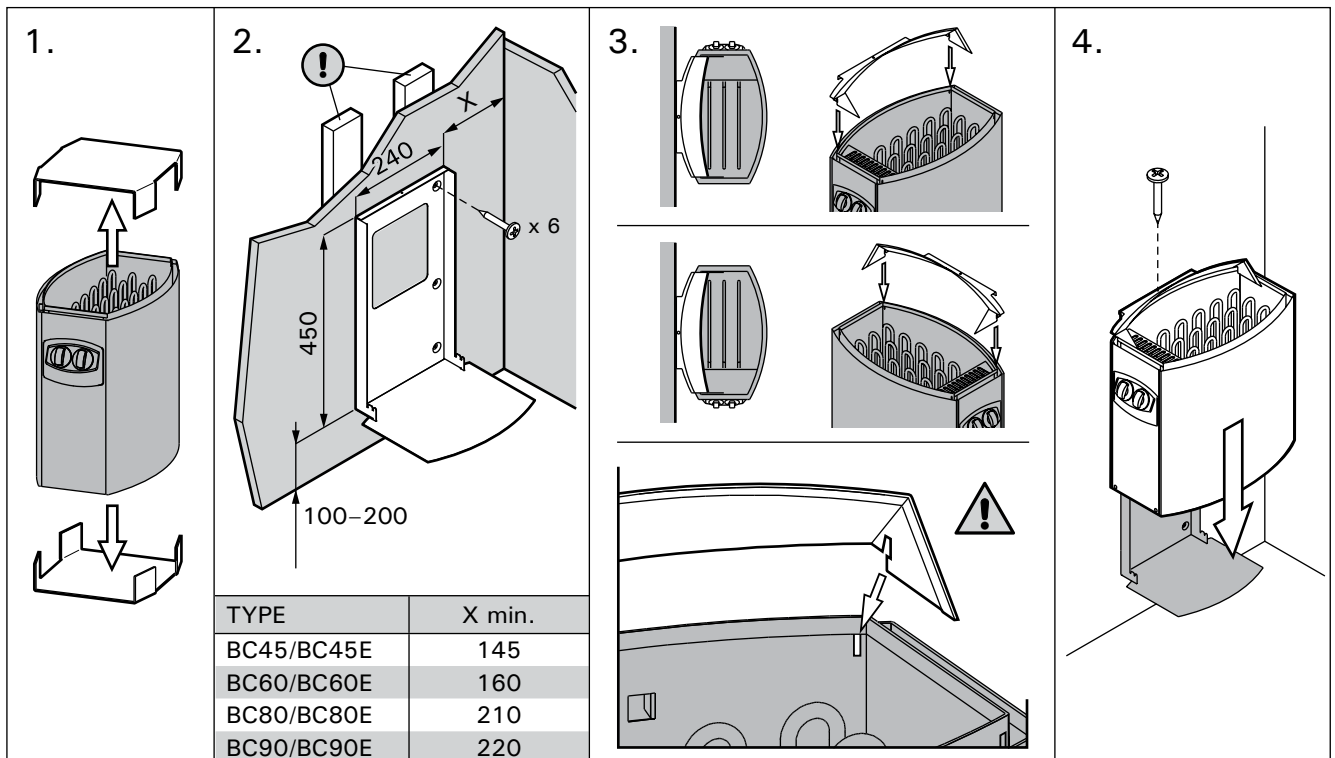

Figure 7. Fastening the heater on a wall (all dimensions in millimeters)
Abbildung 7. Befestigung des Saunaofens an der Wand (alle Abmessungen in Millimetern)

3.3. Electrical Connections

The heater may only be connected to the electrical network in accordance with the current regulations by an authorised, professional electrician.

- The heater is semi-stationarily connected to the junction box (figure 8: A) on the sauna wall. The junction box must be splash-proof, and its maximum height from the floor must not exceed 500 mm.
- The connecting cable (figure 8: B) must be of rubber cable type H07RN-F or its equivalent. **NOTE! Due to thermal embrittlement, the use of PVC-insulated wire as the connecting cable of the heater is forbidden.**
- If the connecting and installation cables are higher than 1000 mm from the floor in the sauna or inside the sauna room walls, they must be able to endure a minimum temperature of 170 °C when loaded (for example, SSJ). Electrical equipment installed higher than 1000 mm from the sauna floor must be approved for use in a temperature of 125 °C (marking T125).
- In addition to supply connectors, the BC heaters are equipped with a connector (P), which makes the control of the electric heating possible (figure 10). Voltage control is transmitted from the heater when it is switched on. The control cable for electrical heating is brought directly into the junction box of the heater, and from there to the terminal block of the heater along a rubber cable with the same cross-section area as that of the connecting cable.
- **When closing the cover of the connection box make sure that the upper edge of the cover is placed correctly.** If the upper edge is misplaced water can enter the connection box. Figure 8.

3.3. Elektroanschlüsse

Der Anschluss des Saunaofens an das Stromnetz darf nur von einem zugelassenen Elektromonteur unter Beachtung der gültigen Vorschriften ausgeführt werden.

- Der Saunaofen wird halbfest an die Klemmdose (Abb. 8: A) an der Saunawand befestigt. Die Klemmdose muß spritzwasserfest sein und darf höchstens 500 mm über dem Fußboden angebracht werden.
- Als Anschlusskabel (Abb. 8: B) wird ein Gummikabel vom Typ H07RN-F oder ein entsprechendes Kabel verwendet. **ACHTUNG! PVC-isolierte Kabel dürfen wegen ihrer schlechten Hitzebeständigkeit nicht als Anschlusskabel des Saunaofens verwendet werden.**
- Falls der Anschluss oder die Montagekabel höher als in 1000 mm Höhe über dem Boden in die Sauna oder die Saunawände münden, müssen sie belastet mindestens eine Temperatur von 170 °C aushalten (z.B. SSJ). Elektrogeräte, die höher als 1000 mm vom Saunaboden angebracht werden, müssen für den Gebrauch bei 125 °C Umgebungstemperatur zugelassen sein (Vermerk T125).
- Die BC-Saunaöfen sind zusätzlich zum Netzanschluss mit einer Klemme (P) ausgestattet, welche die Möglichkeit zur Steuerung der Elektroheizung bietet (Abb. 10). Der Ofen übernimmt mit dem Einschalten die Spannungsregelung. Das Steuerungskabel für die Elektroheizung wird direkt zur Klemmdose des Saunaofens gelegt und von dort aus durch ein Gummikabel der gleichen Stärke weiter zur Reihenklemme des Saunaofens geleitet.
- **Achten Sie beim Schließen des Deckels des Anschlusskastens darauf, dass sich der Deckel vollständig verschließt.** Wenn der Deckel nicht richtig sitzt, kann Wasser in den Anschlusskasten laufen. Abbildung 8.

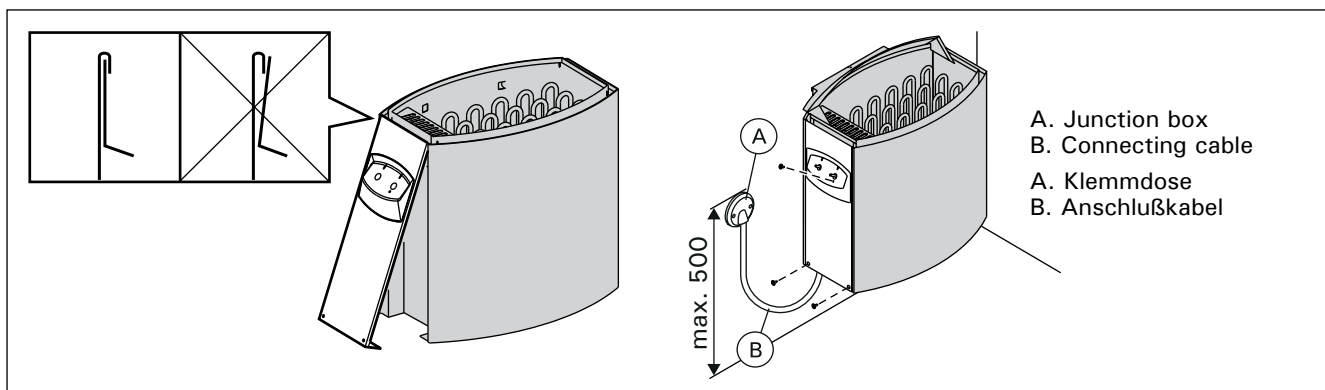

Figure 8. Closing the cover of the connection box (all dimensions in millimeters)
Abbildung 8. Das Verschließen des Anschlusskastens (alle Abmessungen in Millimetern)

3.3.1. Electric Heater Insulation Resistance

When performing the final inspection of the electrical installations, a "leakage" may be detected when measuring the heater's insulation resistance. The reason for this is that the insulating material of the heating elements has absorbed moisture from the air (storage, transport). After operating the heater for a few times, the moisture will be removed from the heating elements.

Do not connect the power feed for the heater through the RCD (residual current device)!

3.3.1. Isolationswiderstand des Elektrosaunaofens

Bei der Endkontrolle der Elektroinstallationen kann bei der Messung des Isolationswiderstandes ein "Leck" auftreten, was darauf zurückzuführen ist, daß Feuchtigkeit aus der Luft in das Isolationsmaterial der Heizwiderstände eingetreten ist (bei Lagerung und Transport). Die Feuchtigkeit entweicht aus den Widerständen nach zwei Erwärmungen.

Schalten Sie den Netzstrom des Elektrosaunaofens nicht über den Fehlerstromschutzschalter ein!

3.4. Installation of the Control Unit and Sensors (BC-E)

The control unit includes detailed instructions for fastening the unit on the wall. Install the temperature sensor on the wall of the sauna room above the heater. It should be installed on the lateral centre line of the heater, 100 mm downwards from the ceiling. Figure 6.

Do not place the supply air vent so that the air flow cools the temperature sensor. Figure 5.

3.5. Resetting the Overheat Protector

If the temperature of the sauna room becomes dangerously high, the overheat protector will permanently cut off the supply of the heater. The overheat protector can be reset after the heater has cooled down.

BC

The reset button is located inside the heater's connection box (figure 9). **Only persons authorised to carry out electrical installations can reset the overheat protector.**

Prior to pressing the button, the cause of the fault must be found.

- Are the stones crumbled and pressed together?
- Has the heater been on for a long time while unused?
- Is the sensor of the thermostat out of place or broken?
- Has the heater been banged or shaken?

BC-E

See the installation instructions for control unit.

3.4. Anschluß des Steuergerätes und der Fühler (BC-E)

In Verbindung mit dem Steuergerät werden genauere Anweisungen zu dessen Befestigung an der Wand gegeben. Der Temperaturfühler wird an der Saunawand oberhalb des Saunaofens, 100 mm unterhalb der Decke auf der Achse in Breitenrichtung des Saunaofens angebracht. Abbildung 6.

Luftzufuhr nicht so anbringen, dass sie den Temperaturfühler abkühlt. Abbildung 5.

3.5. Zurückstellen des Überhitzungsschutzes

Wenn die Temperatur in der Saunakabine gefährlich stark ansteigt, unterbricht der Überhitzungsschutz die Stromzufuhr zum Ofen permanent. Der Überhitzungsschutz kann nach Abkühlen des Ofens zurückgesetzt werden.

BC

Der Rücksetzungsknopf befindet sich im Anschlussgehäuse des Ofens (Abb. 9). **Nur eine zu Elektroinstallationen befugte Person darf diese Arbeit ausführen.**

Vor Betätigung des Knopfes muß die Ursache der Fehlfunktion festgestellt werden:

- Sind die Steine im Saunaofen verkeilt oder spröde?
- War der Saunaofen lange angeschaltet und wurde nicht benutzt?
- Ist der Thermostatfühler an einem falschen Platz oder defekt?
- War der Saunaofen starken Stößen ausgesetzt?

BC-E

Siehen Sie Gebrauchs- und Montageanleitung des Steuergeräts.

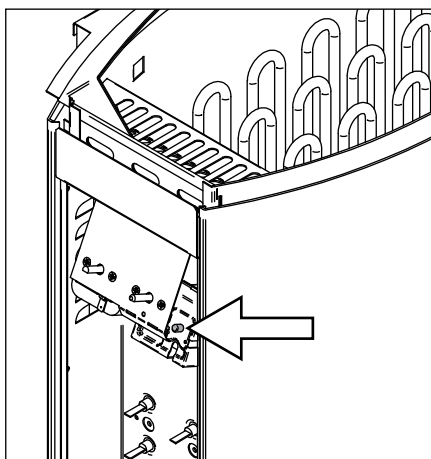

Figure 9. Reset button for overheat protector
Abbildung 9. Rücksetzknopf des Überhitzungsschutzes

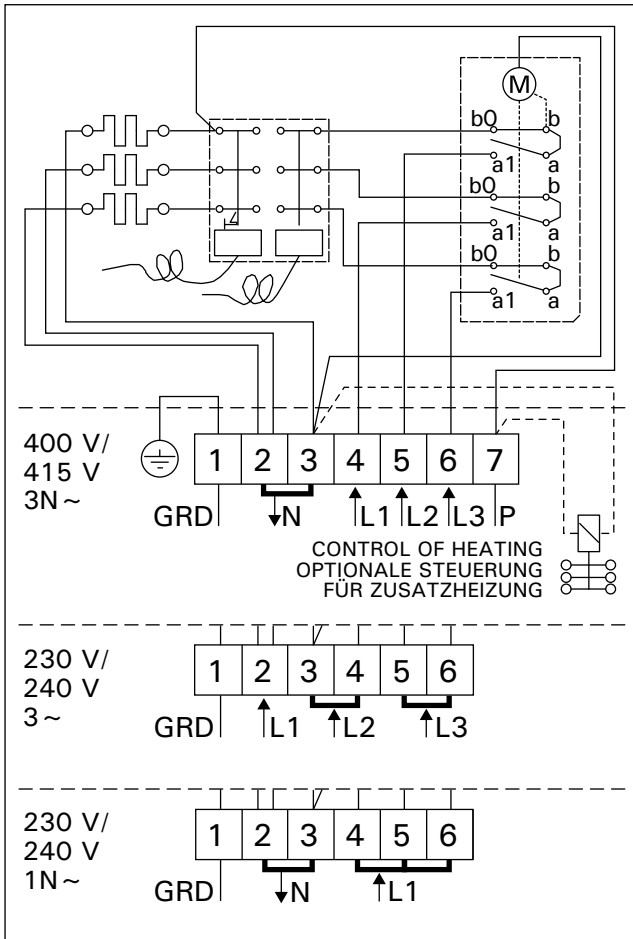

Figure 10. Electrical connections of BC heater
Abbildung 10. Elektroanschlüsse des Saunaofens BC

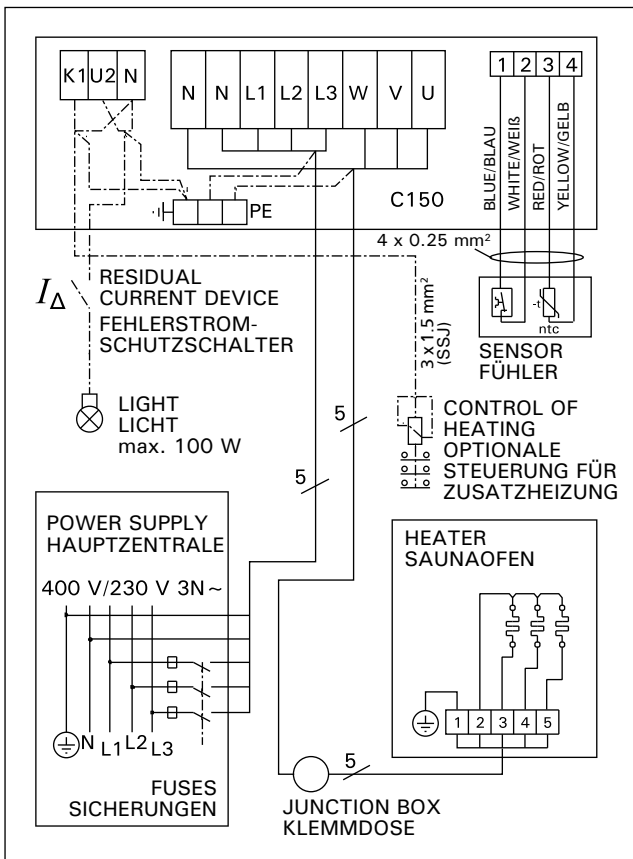

Figure 12a. 3-phase electrical connections of control unit C150 and BC-E heater
Abbildung 12a. 3-phasiger Elektroanschlüsse das Steuergerät C150 und des Saunaofens BC-E

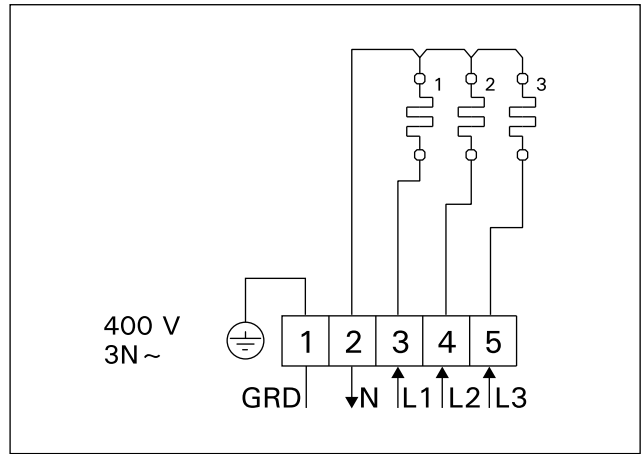

Figure 11. Electrical connections of BC-E heater
Abbildung 11. Elektroanschlüsse des Saunaofens BC-E

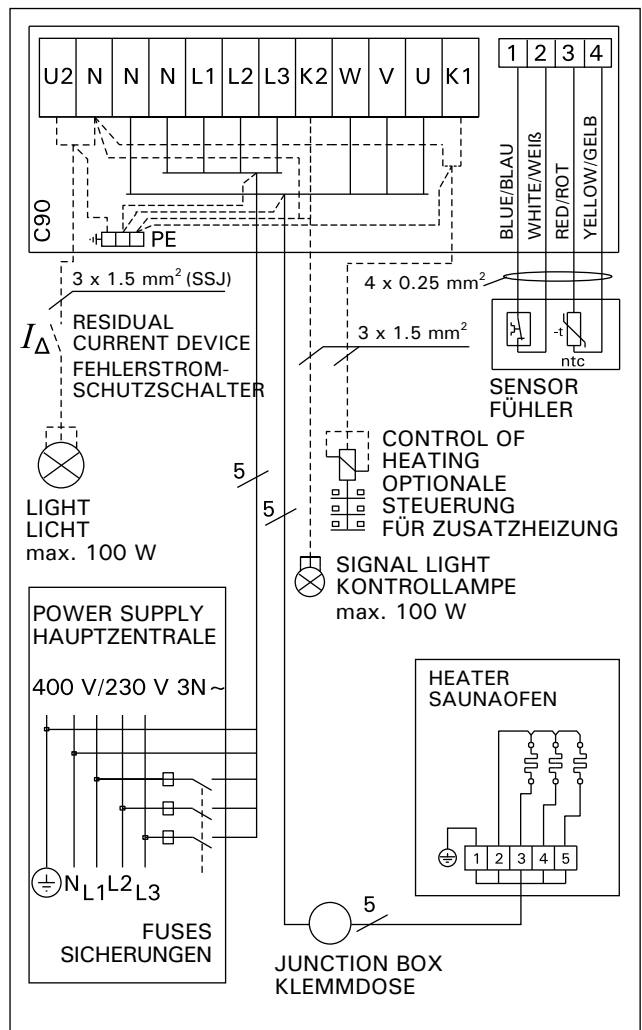

Figure 12b. 3-phase electrical connections of control unit C90 and BC-E heater
Abbildung 12b. 3-phasiger Elektroanschlüsse das Steuergerät C90 und des Saunaofens BC-E

4. VARAOSAT

4. SPARE PARTS

4. ЗАПАСНЫЕ ЧАСТИ

4. REZERVES DAŁAS

4. PIÈCES DÉTACHÉES

4. CZĘŚCI ZAMIENNE

4. RESERVDELAR

4. ERSATZTEILE

4. VARUOSAD

4. ATSARGINĒS DETALĒS

4. RESERVEONDERDELEN

4. NÁHRADNÍ DÍLY

1	ZSB-224	1500 W/230 V
2	ZSB-226	2000 W/230 V
3	ZSB-228	2670 W/230 V
4	ZSB-229	3000 W/230 V
5	ZSK-510	⌚ (BC)
6	ZSB-125	
7	ZSK-520	°C (BC)
8	ZSB-115	

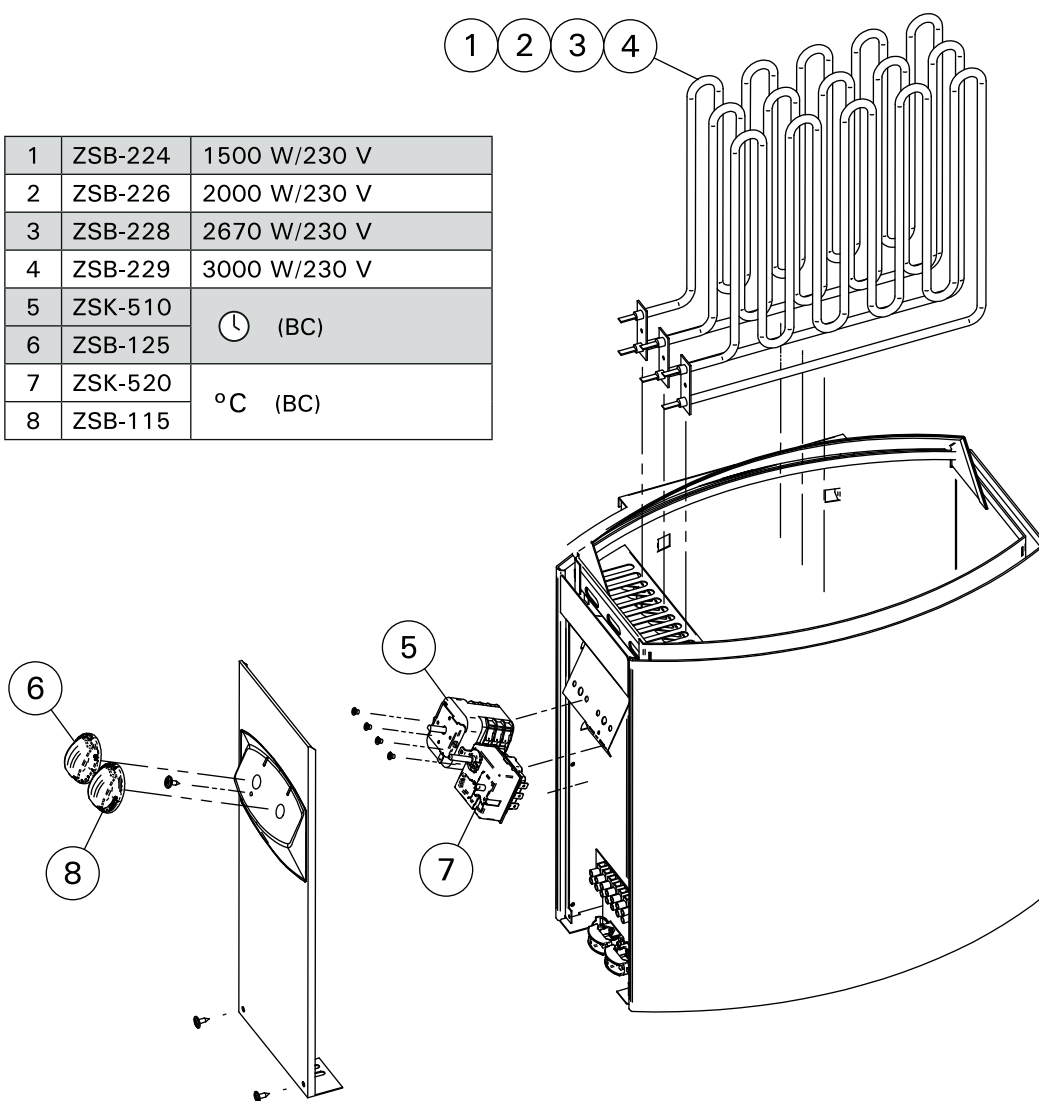

HARVIA

Harvia Oy
PL12
40951 Muurame
Finland
www.harvia.fi

Inštrukcie na používanie

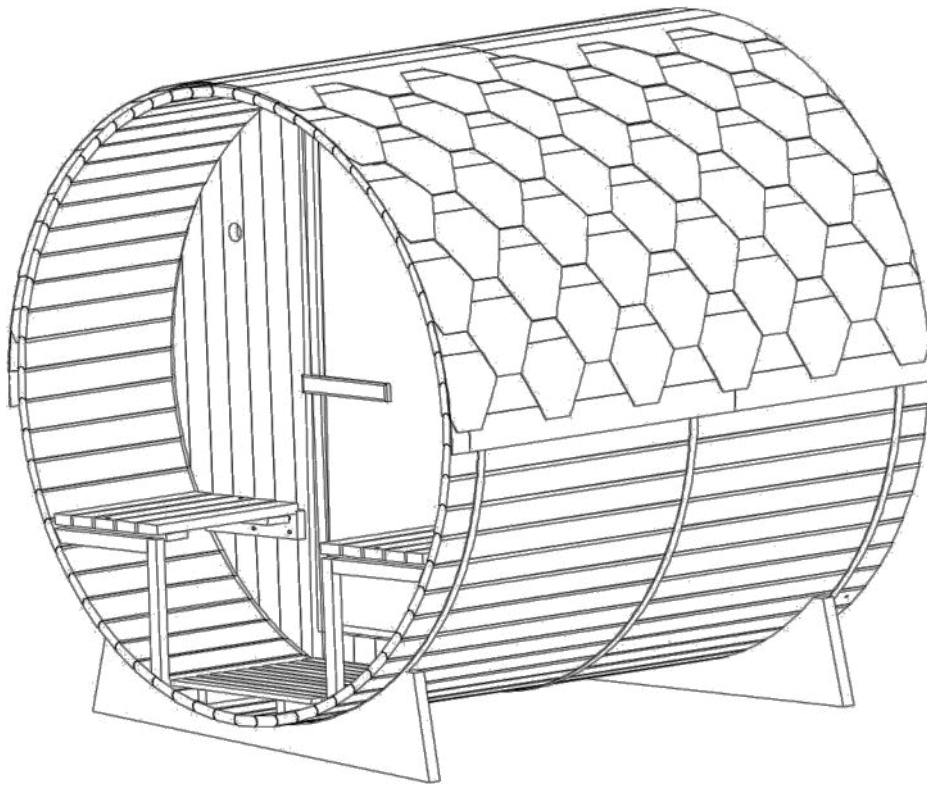

Infračervené žiarenie robí život zdravším

Odporúčanie

Pred prvým použitím sauny si pozorne prečítajte tieto pokyny.

Odporúčame ho skladovať na bezpečnom mieste, aby ste ho mohli v budúcnosti znova použiť.

- Drevo je živý prvok. Pre zachovanie pôvodného vzhľadu je dôležité drevo ošetriť zvonku proti vlhkosti.
- Umiestnite saunu na úplne rovný a tvrdý povrch.
- Nepoužívajte tekuté čistiace prostriedky. Pred čistením saunu vypnite a použite vlhkú handričku.
- Chráňte napájací kábel sauny, aby ste zabránili jeho stlačeniu alebo stlačeniu.
- Pred výmenou určitých dielov sa uistite, že sú špecifikované výrobcom alebo majú rovnaké vlastnosti ako originálne diely. Nesprávna výmena môže spôsobiť požiar, skrat alebo poškodenie sauny. Dôrazne odporúčame, aby ste sa poradili s kvalifikovaným technikom.
- Aby ste predišli riziku popálenia alebo úrazu elektrickým prúdom, nepoužívajte kovové nástroje
- Domáce zvieratá sa nesmú nosiť do sauny.
- Nenechávajte saunu zapnutú bez dozoru.
- Nenechávajte saunu zapnutú dlhšie ako 3 hodiny, aby ste predišli predčasnému poškodeniu zariadenia. Po 3 hodinách nepretržitého používania saunu vypnite aspoň na jednu hodinu.
- Na dvere sauny odporúčame neinštalovať uzamykací systém.
- Pred pripojením sauny k zdroju energie skontrolujte, či sú elektronické časti správne zapojené.

Bezpečnosť

DÔLEŽITÝ!

Pred nastavením a používaním sauny si pozorne prečítajte bezpečnostné pokyny.

Pokyny sú dôležité pre vašu bezpečnosť, preto ich prísne dodržiavajte.

Dávajte si pozor na hypertermiu, úpal alebo vyčerpanie z tepla, ktoré môžu byť spôsobené alebo zhoršené nedodržaním bezpečnostných pokynov. Medzi príznaky patrí horúčka, rýchly pulz, závraty, mdloby, letargia a necitlivosť v celom tele alebo jeho častiach. Účinky sú: znížené vnímanie tepla, nevedomosť o hroziacom nebezpečenstve, bezvedomie.

Sauna sa nesmie používať:

- Deti do 6 rokov.
- Ľudia so silnými reakciami na slnečné svetlo.
- Staršie osoby alebo osoby so zdravotným postihnutím.
- Osoby s už existujúcimi zdravotnými problémami, ako sú srdcové choroby, vysoký alebo nízky krvný tlak, problémy s krvným obehom alebo cukrovka, bez predchádzajúcej lekárskej pomoci.
- Tehotná žena. Nadmerná teplota môže ohroziť plod.
- Ľudia trpiaci dehydratáciou, otvorenými ranami, očnými chorobami, popáleninami alebo úpalom.

Deti od 6 do 16 rokov môžu využívať saunu za predpokladu, že sú pod neustálym dohľadom zodpovednej dospeléj osoby a teplota neprekročí 60°C.

Ak máte zdravotné problémy, užívate lieky alebo máte poranené svaly a väzy, saunu môžete využívať len po predchádzajúcej konzultácii a schválení lekárom.

Ak máte chirurgické implantáty, nesmiete používať saunu bez predchádzajúcej konzultácie a schválenia lekárom.

Nepoužívajte saunu po namáhavej aktivite.

Počkajte 30 minút, kým vaše telo vychladne.

Nestráňte v saune naraz viac ako 40 minút.

Nekonzumujte alkohol ani drogy pred alebo počas relácie.

Počas používania nespíte v saune.

Aby ste predišli riziku prehriatia, zapojte saunu do dostatočne výkonnej elektrickej zásuvky a do tej istej elektrickej zásuvky nepripájajte iné elektrické zariadenia.

Aby ste predišli riziku úrazu elektrickým prúdom alebo poškodenia sauny, nepoužívajte ho:

- Počas búrky.
- Ak je elektrický kábel poškodený, musí ho vymeniť kvalifikovaná osoba.
- Ak sa napájací kábel prehrieva, musí ho skontrolovať kvalifikovaná osoba.
- Ak potrebujete vymeniť žiarovku, počkajte, kým sa sauna nevypne a nevychladne.

Pred zapojením alebo vypnutím napájania si osušte ruky.

Nikdy nepracujte s mokkými rukami alebo nohami.

Nezapínajte ani nevypínajte napájanie ani kúrenie rýchlo, pretože by to mohlo poškodiť elektrický systém.

Nepokúšajte sa saunu opravovať sami bez súhlasu predajcu alebo výrobcu sauny.

Neoprávnené pokusy o opravu rušia záruku výrobcu.

V saune nepoužívajte čistiace prostriedky.







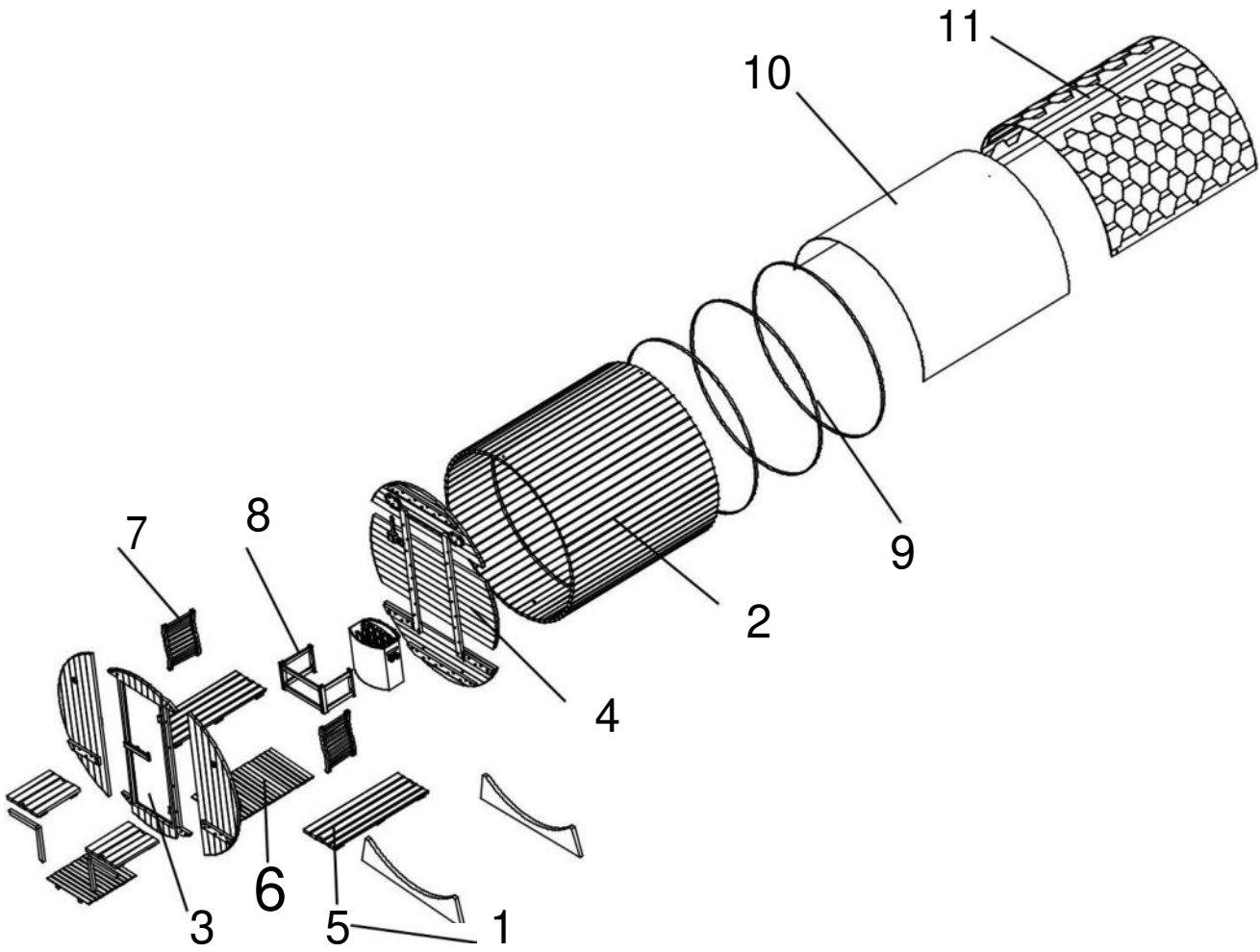



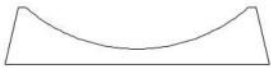

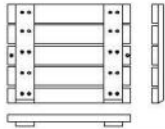

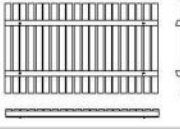

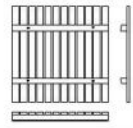
Neukladajte predmety do sauny alebo na saunu.

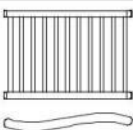
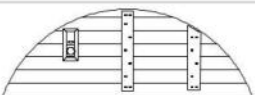
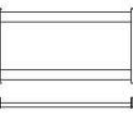
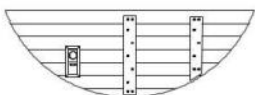
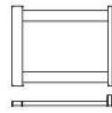
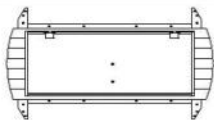
Neumiestňujte horľavé materiály alebo chemikálie do blízkosti sauny.

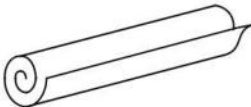

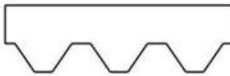
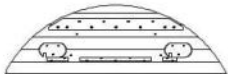
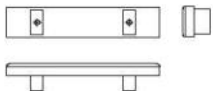

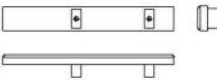
Popis sauny

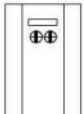
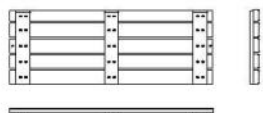
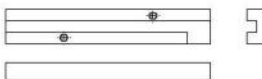



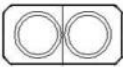
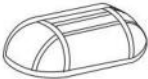

Popis sauny

1		(1400x300x33mm)2x	5.2		(426x398x30mm)2x
2.1		(1800x93x30mm)2x	5.3		(532x425x50mm)2x
2.2		(1800x93x30mm)1x	6.1		(990x585x40mm) 1x
2.3		(1800x93x30mm)60x	6.2		(535x585x40mm) 1x
2.4		(1800x93x30mm)1x	7		(520x330x65mm)2x
3.1		(1758x575x30mm)1x	8.1		(560x300x40mm)1x
3.2		(1650x575x30mm)1x	8.2		(378x300x40mm)2x
3.3		(1758x952x30mm) 1x	9		3x hlaveň pneumatiky
4.1		(1404x80x20mm)1x	10		(3000x1800mm) 1x
4.2		(1404x80x20mm)1x	11		(1000x320mm) 60x
4.3		(1574x488x30mm) 1x	12		(250x50x45mm) 1x
4.4		(1758x783x30mm) 1x	13		(350x50x45mm) 1x
4.5		(1574x488x30mm) 1x	14		1x Sporák
5.1		(1152x425x50mm)2x	15		(177x80x30mm)1x

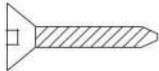
Popis sauny

16		1x Miska na vodu	20		1x hustomer
17		2x Kryt osvetlenia 21			1x hodín
18		2x držiak na poháre	22		1x naberačka
19		1x Vedro			

							
Ø5x50	Ø4x50	Ø4x30	Ø3x35	Ø4x12	Ø6x70		
44x	20x	8x	66x	240x	2x	2x	

Predtým, ako nájdete vhodné miesto pre saunu, pozorne si prečítajte montážny návod.

Sauna je určená výhradne na vonkajšiu inštaláciu.

Vyberte izbu:

- V suchej miestnosti, na rovnom a stabilnom povrchu, ktorý unesie váhu sauny.
- Výška musí byť taká, aby ste dosiahli strop a vykonávali elektrické prípojky a údržbárske práce.
- V blízkosti zdrojov vody, plameňov alebo horľavých materiálov.

Praktické rady

- Upozorňujeme, že na postavenie sauny sú potrebné aspoň 3 dospelé osoby.
- Skôr ako začnete, jasne identifikujte každý panel
- Pri inštalácii vedzte napájací kábel sauny tak, aby bol ľahko prístupný.
- Upozorňujeme, že medzi modelmi existujú rozdiely.

DÔLEŽITÝ!

Skontrolujte vybranie a priemer vyvŕtaných otvorov, aby ste predišli poškodeniu dreva.

Potrebné nástroje



Skrutkovač



Merač



Ceruzka



Nôž



2 klúče



Akumulátorová vŕtačka



Vŕtačka na drevo



Imbusový kľúč



Stupňovitý rebrík



Kladivo

Montážny návod

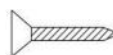
 Ø 5 x 50 20ks

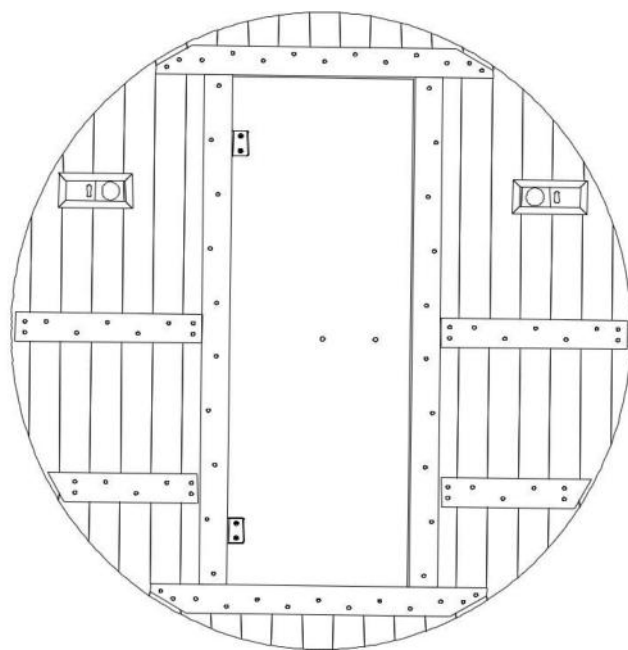
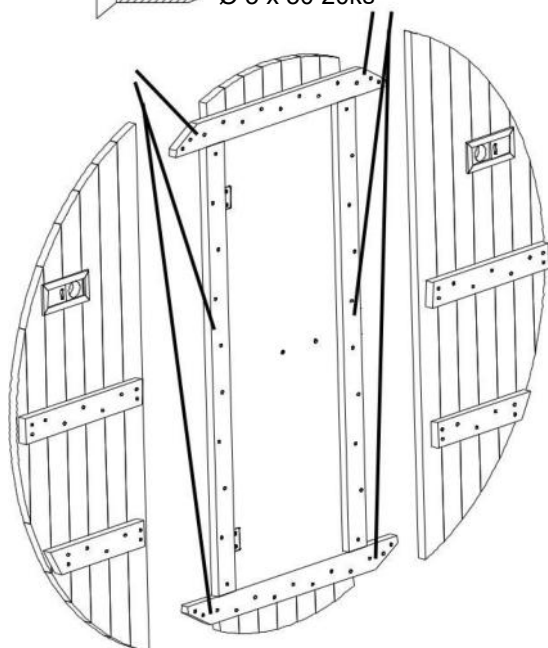

 Ø 3 x 35 2ks

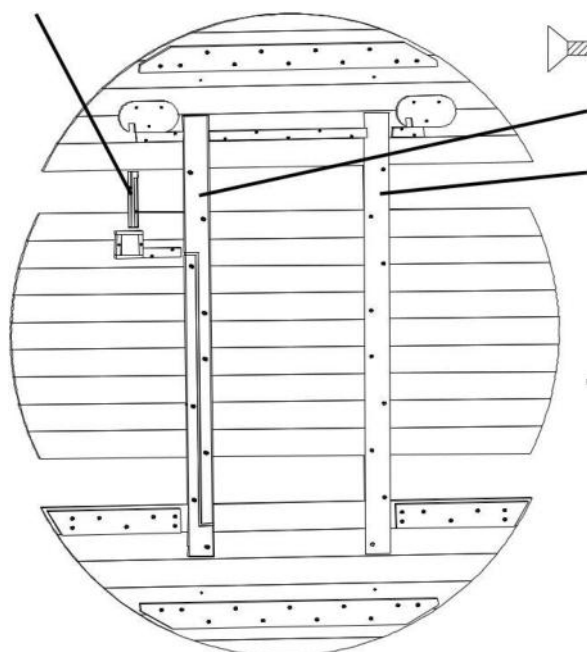

 Ø 5 x 50 18ks

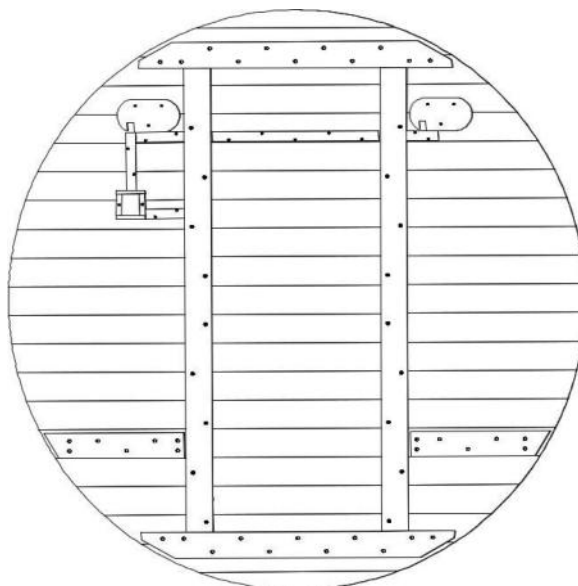

Najprv je potrebné zostaviť prednú a zadnú stenu ako celok.

Predná strana je rozdelená na tri časti vľavo a vpravo, zadná časť je rozdelená na tri časti v hornej a dolnej časti.

Montážny návod

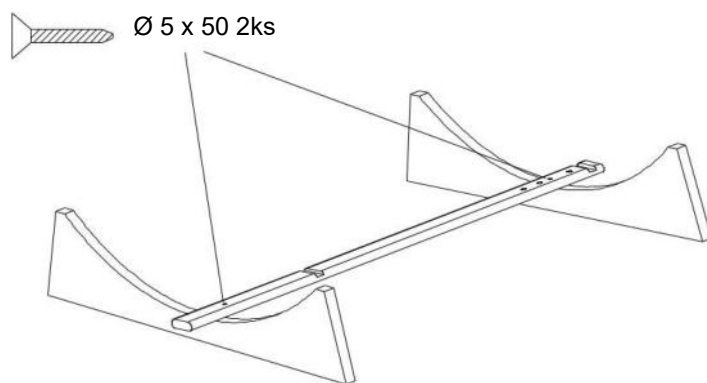

Báza

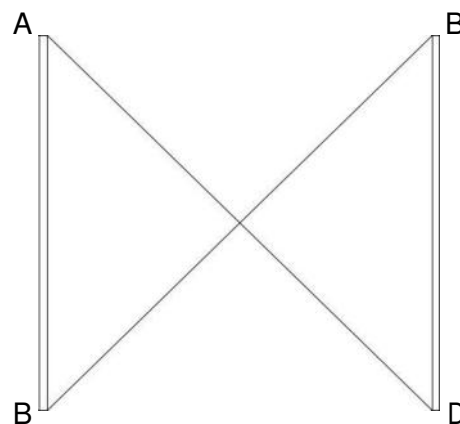

$$AD = BC \quad AB = BD$$

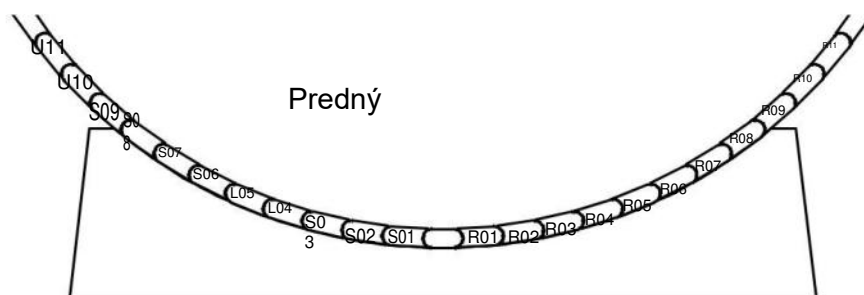

Každá lamela je očíslovaná a označená.

Ľavá strana je L01, L02, L03..... L38 zdola nahor;

Pravá strana je R01 R02 R03..... R38 zdola nahor.

Montážny návod

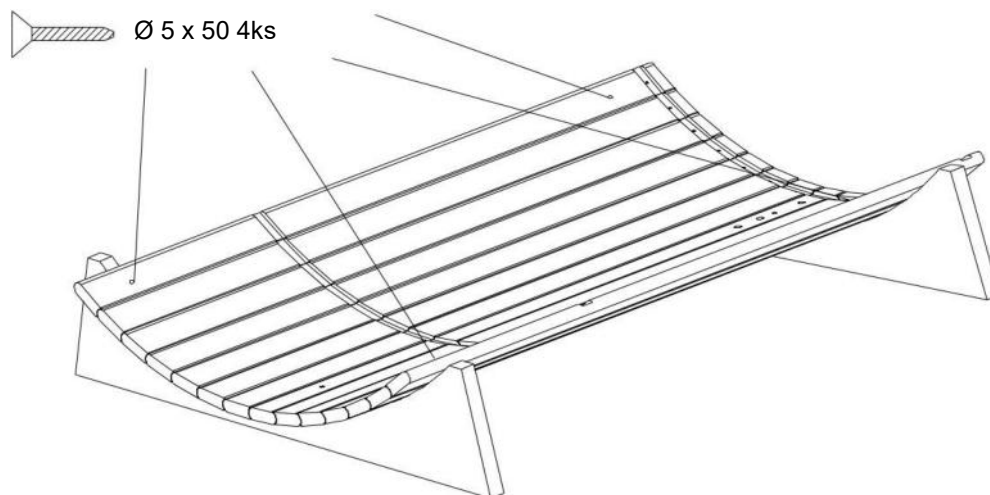

Spodné lamely

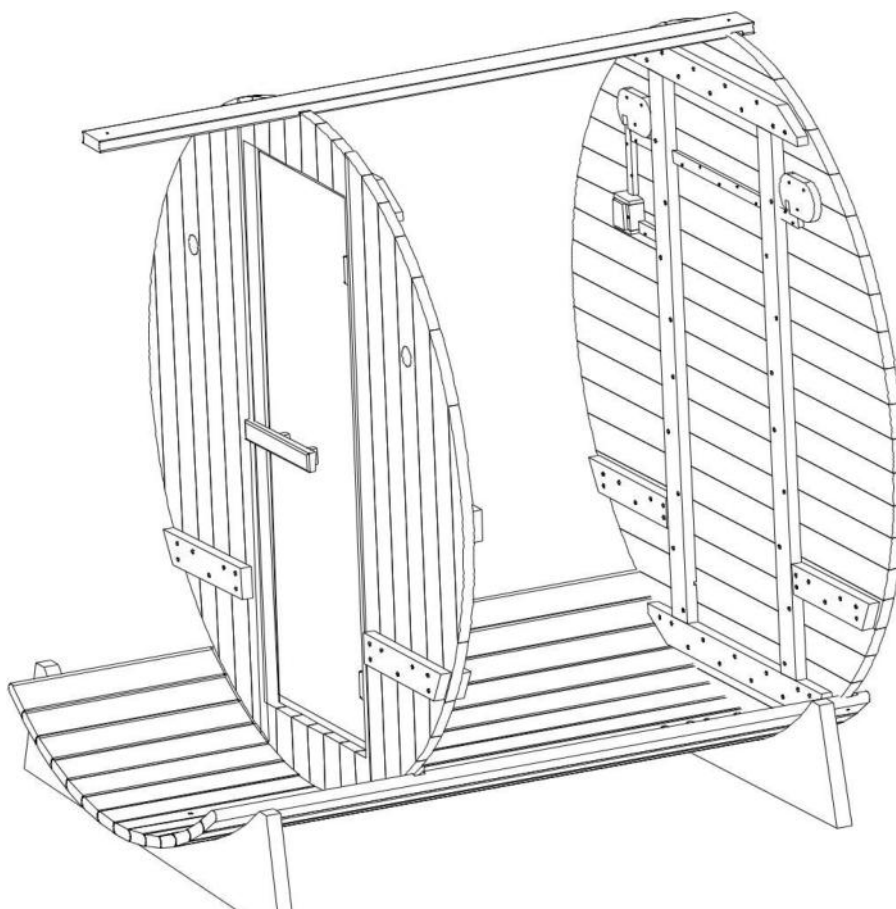

Horná lamela je dočasne inštalovaná ako trvalé ochranné opatrenie počas inštalácie.

Montážny návod

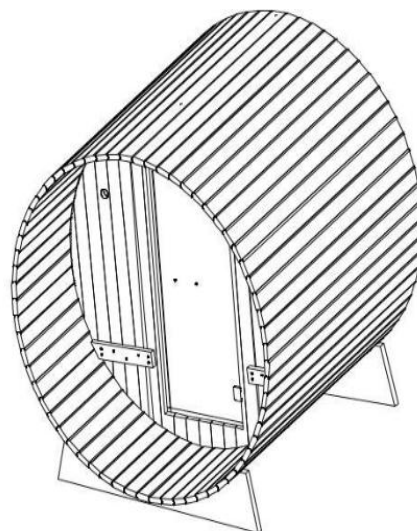
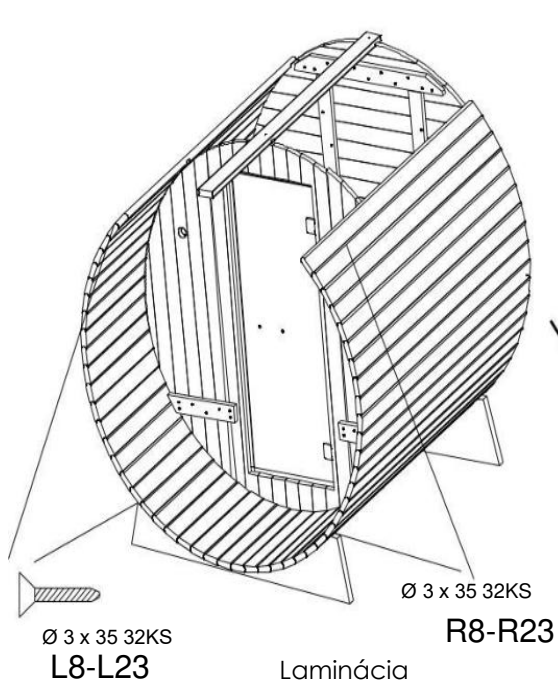

1. Lamely telesa hlavne musia byť počas inštalácie blízko seba, čo prispieva k hornej inštalácii a tesnosti.
2. Skrutky (M3*35 64PCS) sa používajú na upevnenie koľajníc L8-L23 a R8-R23, horné koľajnice sú pevne pripevnené po vytvorení kruhu, hlavneň pripevňuje sa pomocou popruhov z nehrdzavejúcej ocele.

Slabé platne

V závislosti od skutočných požiadaviek na inštaláciu, jedna alebo dve tenké platne v strede hlavne odstránené po uvoľnení skrutiek.

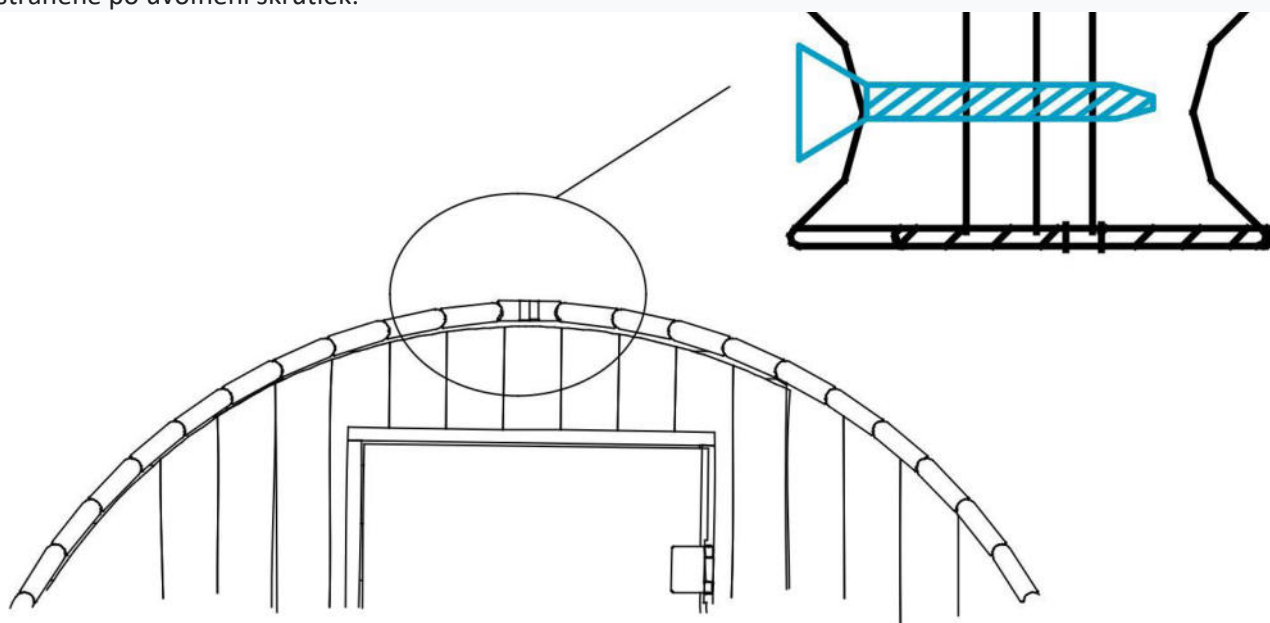

Montážny návod

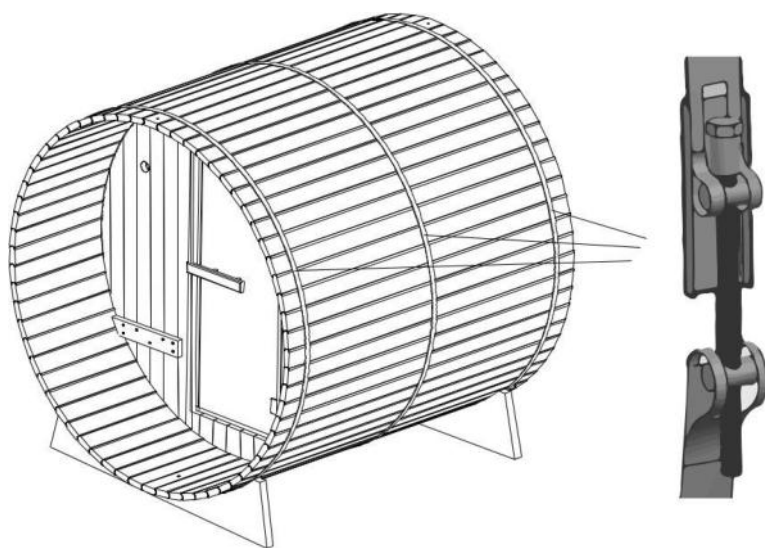

Remienky z nehrdzavejúcej ocele

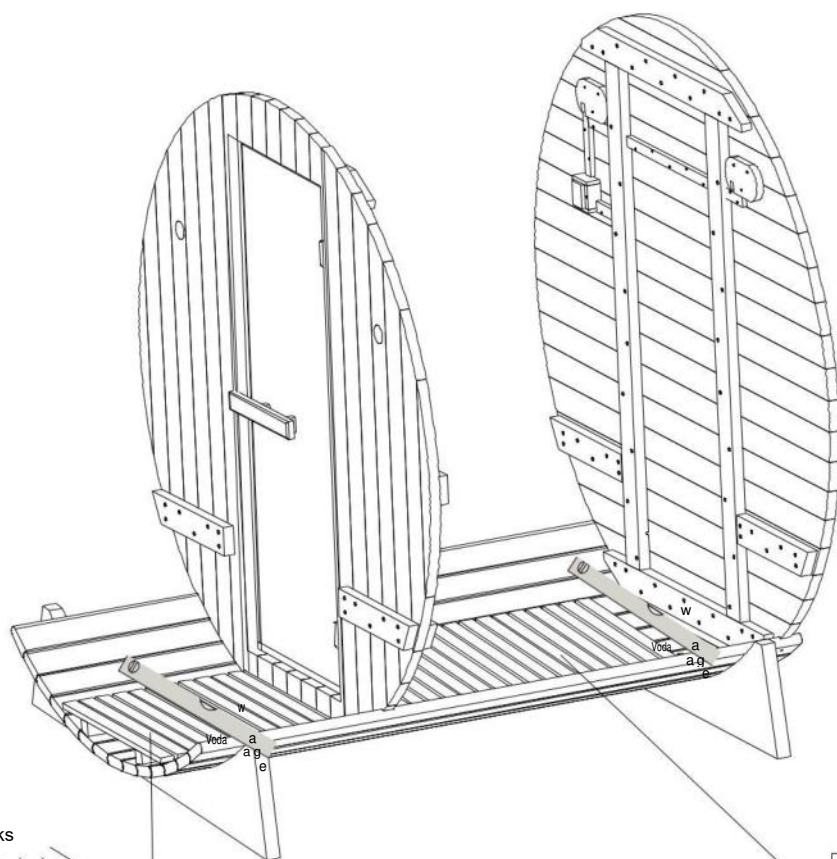

Ø 4 x 50 4ks

Ø 4 x 50 4ks

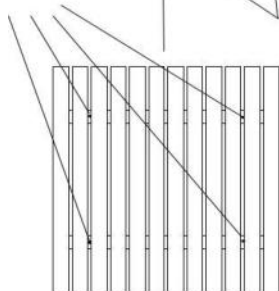

Opierka nôh

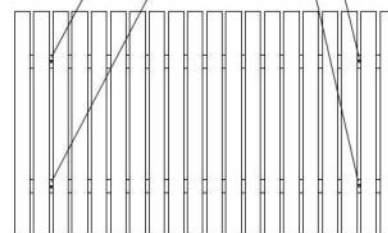

Montážny návod

Držiaky vnútorných a vonkajších sedacích plôch sú predinštalované.
 Vonkajšia základová doska vyžaduje dodatočný nosný rám a nosný rám pripieňuje skrutky k lamelám.
 Vnútorá základová doska nevyžaduje žiadny ďalší nosný rám.
 Upevnenie Blokovacie skrutky panela sedadla musia byť pripevnené k nosnej strane predného a zadného panelu.

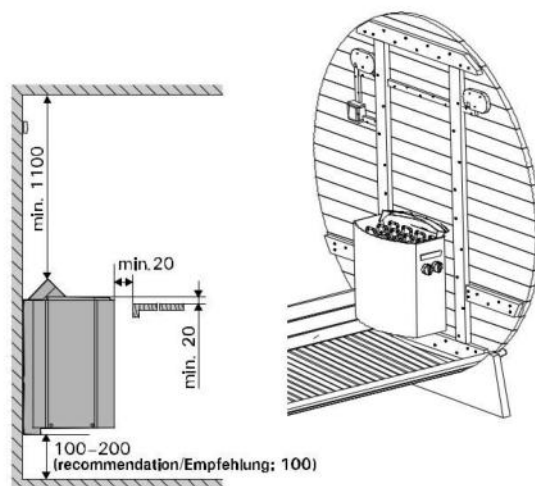
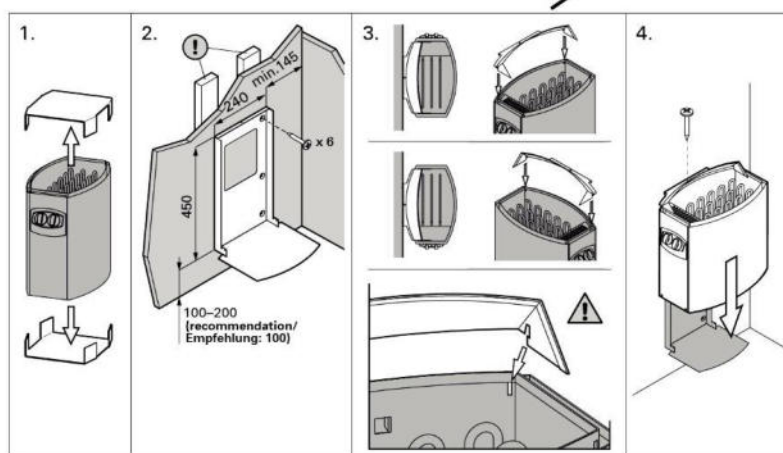
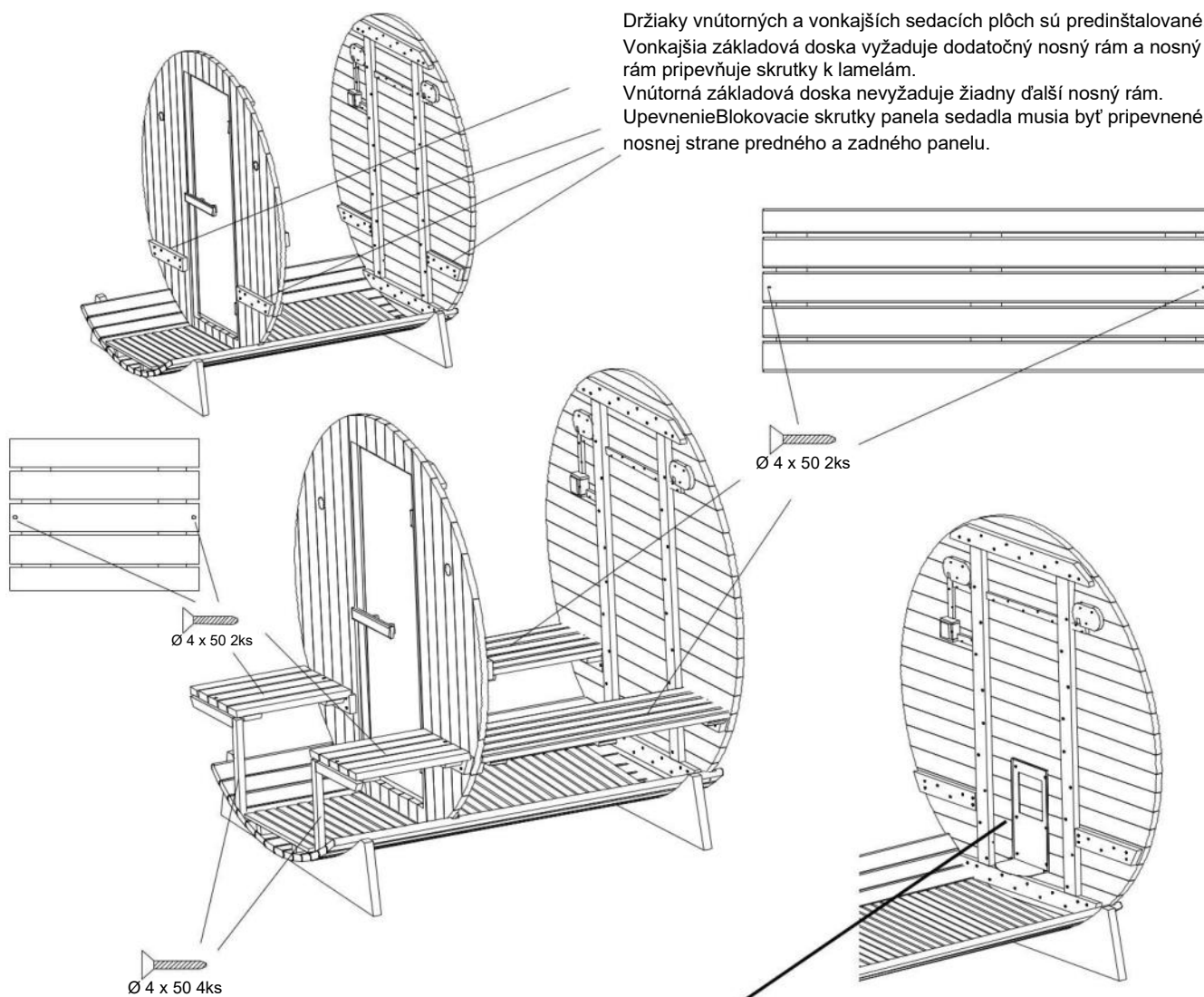

Pri inštalácii sauny musíte najskôr nainštalovať nástenný držiak rámu rúry a potom rúru zavesiť. Podrobné informácie nájdete v diagrame. Podrobné informácie nájdete v návode dodanom so saunovým ohrievačom.

Svetelné vodiče by mali byť pripojené k káblovej základni saunového ohrievača a napájané cez ohrievač sauny.

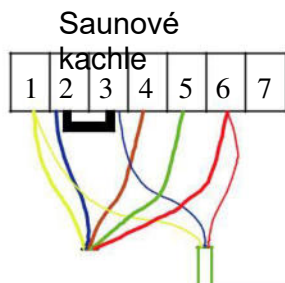
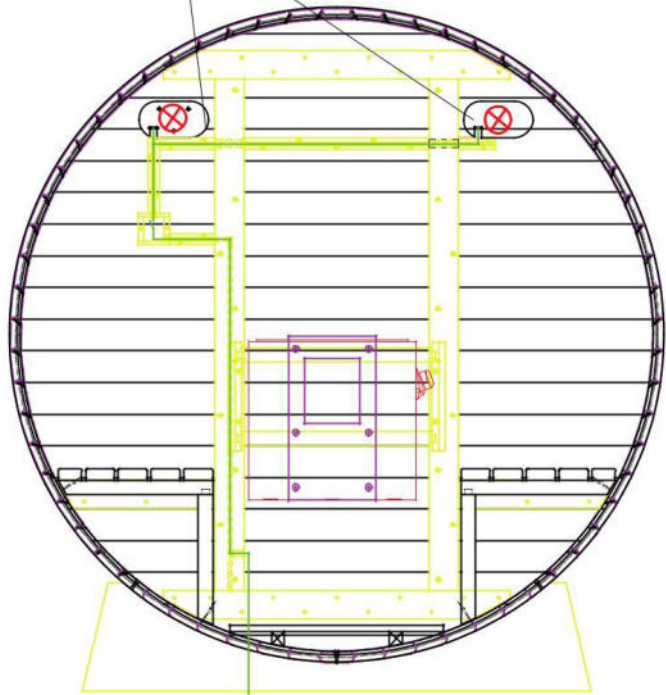
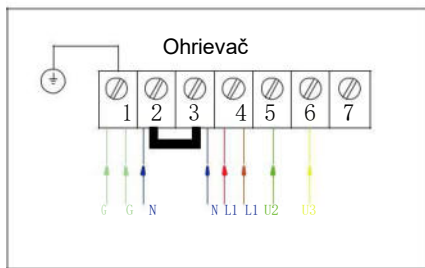
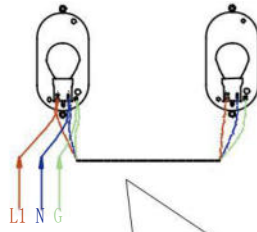

Napätie svetelného zdroja (3 * 0,75 mm²)

Kábel (5 * 2,5 mm²)

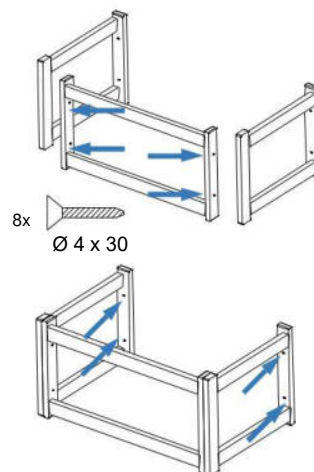
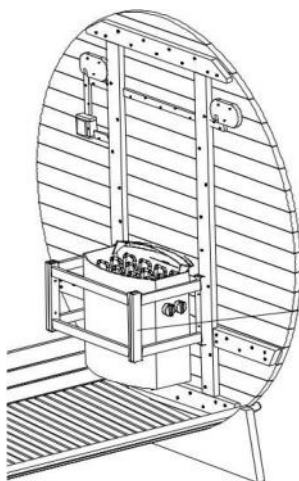

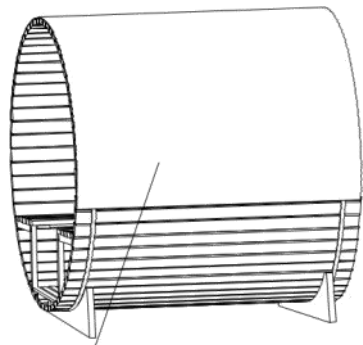

Vodeodolná tkanina

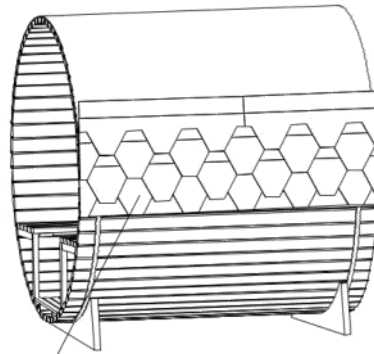

Šindel

Ø 4 x 12 200KS

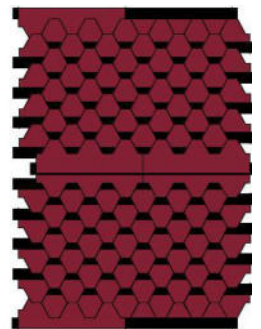
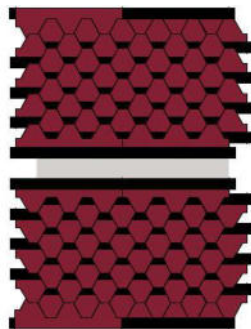
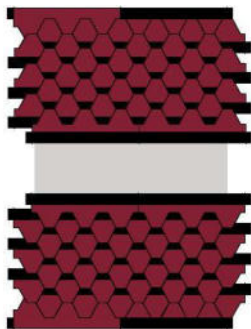
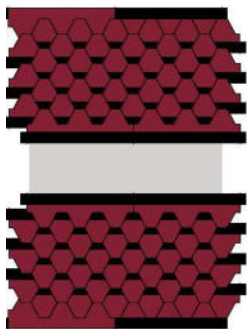
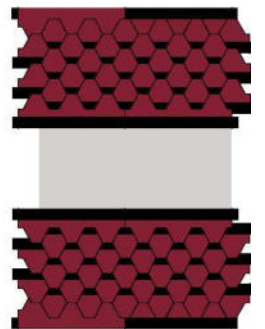
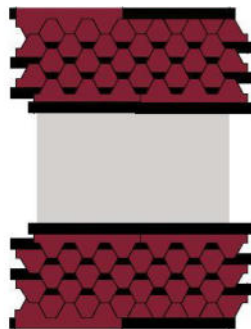
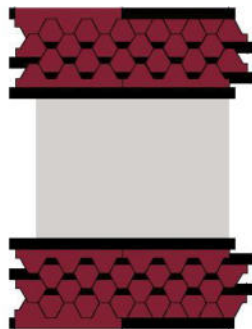
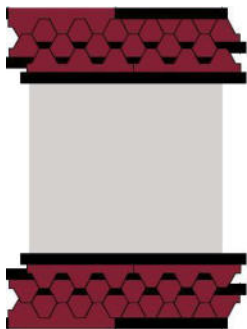
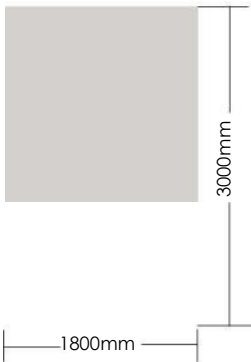

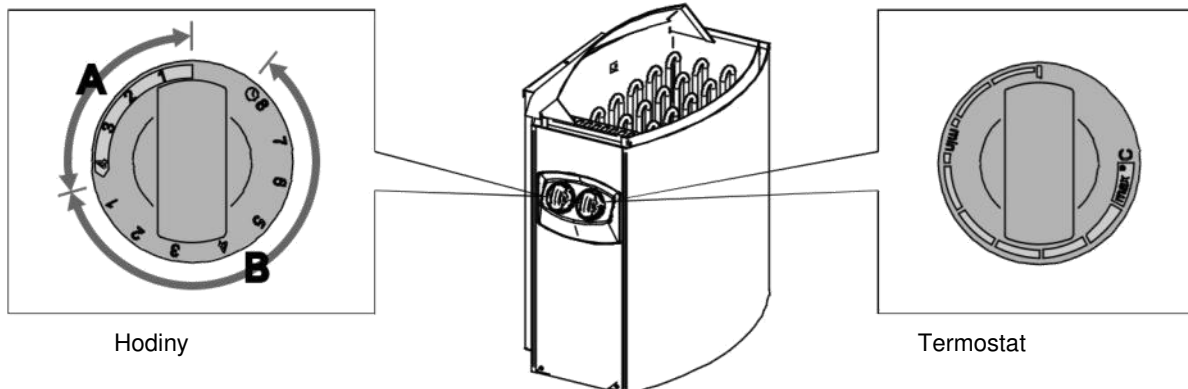

1. Ohrievač zapnutý



Prepnite tlačidlo na "zapnuté".
(časť A na obr. 2, 0-4 hodiny).
Ohrievač sa okamžite začne ohrievať.

2. Prednastavený čas (časovo regulované zapnutie)



Prepínač časovača nastavte do sekcie "Predvoľby" (časť B na obr. 2, 0-8 hodín). Ohrievač sa začne zahrievať, keď časovač prepne spínač späť do polohy "zapnuté". Ohrievač sa potom zapne asi na štyri hodiny.

Podrobné informácie o špecifickom použití a bezpečnostných opatreniach saunového ohrievača nájdete v návode na obsluhu dodanom s ohrievačom sauny.

Údržba

Ochrana dreva

Každú vonkajšiu tyč hlavne vyčistite a po kompletnej montáži naneste prostriedok na ochranu dreva.

Ochranný prostriedok sa musel obnoviť podľa odporúčania použitého výrobku

DÔLEŽITÝ!

Pred vykonaním akejkoľvek práce odpojte napájací kábel kabíny.

Zistené problémy	Možná príčina	Riešenie
Kachle sa nezohrievajú.	Napájací kábel nie je pripojený	Skontrolujte pripojenie napájacieho kábla.
	Všeobecný zdroj napájania je prerušený.	Skontrolujte, či zásuvka a elektrický panel fungujú.
	Kachle sú chránené proti prehriatiu	Vidieť. Pokyny pre kachle..
Saunové svetlo už nie je k dispozícii	Svetelný kábel nie je úplne pripojený	Pripojte kábel.
	Svetlo je rozbité.	Obráťte sa na svojho predajcu.

Služby

1. Vypnite saunu.
2. Odstráňte prach z trhlín v drevenom obložení pomocou vysávača.
3. Vyčistite kabínu vlhkou bavlnenou handričkou, v prípade potreby použite malé množstvo mydla. Opláchnite vlhkou handričkou.
4. Sklo očistite čistiacim prostriedkom na okná / sklo a mäkkou handričkou.
5. Starostlivosť o vonkajšiu časť sauny každé 2 roky vhodným produktom.

DÔLEŽITÝ!

Drevo by malo byť ošetrené ochranným prostriedkom len na vonkajšej strane sauny.

V saune nie je povolená žiadna procedúra.

V saune nepoužívajte benzén, alkohol, chemikálie ani silné čistiace prostriedky, pretože chemické prípravky môžu drevo poškodiť. Saunu nestriekajte vodou.

Prečítajte si pokyny dodané so saunovým ohrievačom na inštaláciu a používanie ohrievača.

Ohrievač môže byť pripojený k elektrickej sieti iba autorizovaným elektrikárom v súlade s platnými predpismi.

**BC45, BC60, BC80, BC90
BC45E, BC60E, BC80E, BC90E**

Inštrukcie na používanie



Táto inštaláčn a prevdzkov prručka je určen pre kontaktujte majiteľa sauny alebo majiteľa sauny starostlivosť o zodpovedn osobu sauny, ako aj osoba zodpovedn za inštaláciu ohrievača sauny elektrikr. Keď je namontovan saunov ohrievač, táto inštalácia a nvod na obsluhu s odoslan na Majiteľa sauny alebo osoby zodpovedn za údržbu sauny odovzdať zodpovednej osobe. Čítajte nahlas uvedenie rry do prevdzky podľa nvodu na obsluhu starostlivo.

Kachle sa používajú na vykurovanie saunovch kabn pri teplote sauny. Použitie pre ostatnch účely s zakzan. Gratulujeme k dobrej voľbe

Zruka:

- Zručná doba na rodinn sauny použité saunov kachle a ovldacie zariadenia m dva (2) roky.
- Zručná doba na saunov kachle a Ovldacie zariadenia inštalované vo verejnch saunch v používa sa v skromnch budovch je jednm z nich (1 rok).
- Zruka sa nevzťahuje na vady, ktoré z dôvodu nesprvnej inštalácie a používania alebo nedodržiavanie pokynov na údržbu boli vytvoren.
- Zruka sa nevzťahuje na poškodenie tie, ktoré s spôsoben inmi použitiami ako vrobou odporúčan saunov kachľov kamene

1.1. Skladanie kameňov saunových kachlí

Vrstvenie tehál pece má veľký vplyv na účinnosť pece (obr. 1).

Dôležité informácie o kameňoch saunových kachlí:

- Kamene by mali mať priemer majú 5-10 cm.

- Používajte iba špicaté saunové kamene s drsným povrchom, ktoré sú určené na použitie v saunových kachliach. Vhodnými typmi hornín sú peridotit, olivinický dolerit a olivín.

- V saune by ohrievač nemal byť mierne porézny

Môžu sa použiť "kamene" vyrobené z keramiky alebo mäkkého mastenca. Absorbujú sa, keď

Nedostatok tepla, ktorý má za následok a poškodenie vykurovacích telies.

- Kamene by mali byť pred stohovaním

Kamenný prach, ktorý sa má oslobodiť.

Pri kladení kameňov majte na pamäti nasledovné:

- Nenechávajte kamene len v rúre jeseň.

- Vyhnite sa klinovým kameňom medzi vykurovacími telesami.

- Voľne stohujte kamene, takto že vzduch môže prúdiť medzi nimi.

- Naskladajte kamene tak, aby netlačte ich na vykurovacie telesá.

- Stohujte kamene na sporák nie vo vysokej hromade.

- V Kamennej komore alebo v blízkosti do ohrievača sauny by nemali byť umiestnené žiadne predmety alebo sa zariadenie nachádza v takom množstve, alebo

Smer toho, ktorý vedie cez saunovú pec zmeniť prúdenie vzduchu

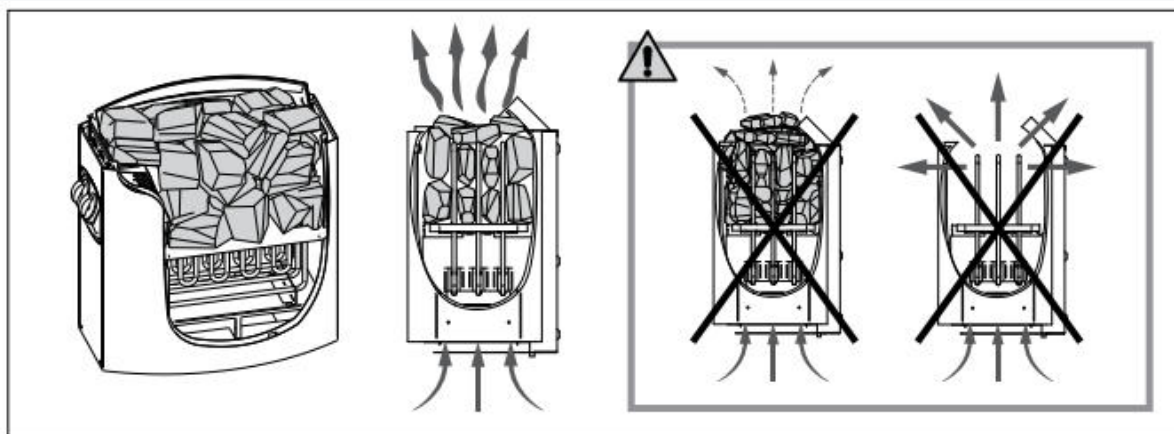

1.1.1. Údržba

V dôsledku veľkých tepelných zmien,

Saunové kamene krehké a krehké. Kamene by mali by sa mali dopĺňať aspoň raz ročne, s pravidelným používaním častejšie. S týmto Ak máte možnosť, odstráňte aj úlomky prachu a kameňa zo spodnej časti ohrievača sauny a vymeňte poškodené kamene. V dôsledku toho optimálny vykurovací výkon a riziko pece zabráni sa prehriatiu.

1.2. Vykurovanie saunovej kabíny

Pri prvom rozcvičení sa oddeľuje od saunového ohrievača a vôňa kameňov. Ak ich chcete odstrániť saunová kabína musí byť dôkladne vetraná.

S tepelnou kapacitou vhodnou pre saunu je izolovaná sauna na dosah jednu hodinu na požadovanú teplotu sauny (2.3.). Kamene saunových ohrievačov sa zvyčajne ohrievajú na teplotu soľanky súčasne so saunovou kabínou. Správna teplota v saunovej kabíne je to okolo 65 až 80 °C.

1.3. Používanie rúry

Pred zapnutím rúry skontrolujte, či na rúre alebo v nej nie sú žiadne predmety

v bezprostrednej blízkosti pece. 1.6.

- Modely rúr BC45, BC60, BC80 a BC90 je dodávaný s časovačom a Vybavený termostatom. Časovač reguluje čas zapnutia rúry, a to teplota termostatu. 1.3.1.-1.3.4.
- Modely rúr BC45E, BC60E, BC80E a BC90E sa dodávajú so samostatným riadená riadiaca jednotka. dávať pozor dodaný návod na použitie ovládať

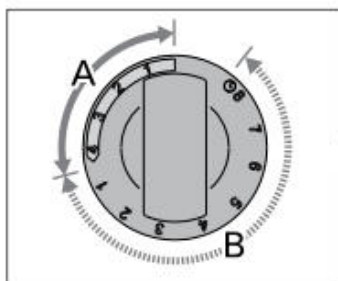

Figure 2. Timer switch
Abbildung 2. Schalter der Zeitschaltuhr

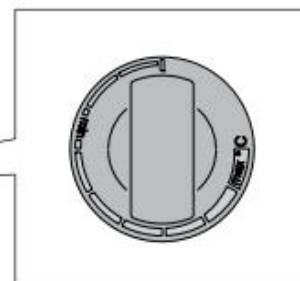
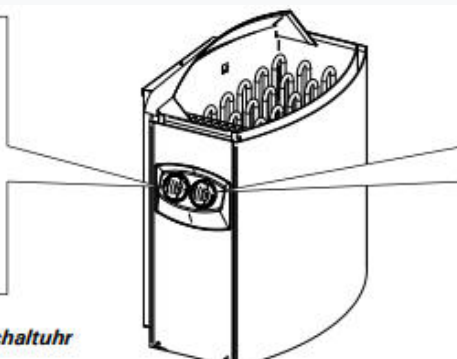

Figure 3. Thermostat switch
Abbildung 3. Thermostatschalter

1.3.1. Zapnutá rúra



Nastavenie časovača do oddielu "a" (oddiel A v Obr. 2, 0-4 hodiny). Rúra sa spustí okamžite sa zahrejte.

1.3.2. Prednastavený čas (časovo riadené zapnutie)



Nastavenie časovača do sekcie "Predpona" (časť B v Obr. 2, 0-8 hodín). Rúra sa spustí zahrejte sa, keď je časovač otočil spínač späť na zapnutú časť. Potom zostane rúra zapnutá asi štyri hodiny

Príklad: Chcete ísť na tri hodiny choďte na prechádzku a potom sa saunujte. Miesto prepnutie časovača do sekcie "Predpona" na čísle 2. Spustí sa časovač. Po dvoch hodinách sa rúra začne zahrievať. Pretože zahriatie sauny trvá asi hodinu, asi po byť pripravený na saunový kúpeľ po dobu troch hodín, takže keď sa vrátite z prechádzky.

1.3.3. Rúra vypnutá



Rúra sa vypne, keď prepnutie späť na nulový časovač Obrátil. Rúru môžete kedykoľvek vypnúť sami stlačením tlačidla Nastavte časovač na nulu. Po saune vypnite kúrenie. Niekedy je vhodné rúru na chvíľu opustiť bežať ďalej do drevených častí sauny správne vyschnúť. **POZORNOSŤ!** Vždy sa uistite, že Rúra je vypnutá a už sa nezohrieva časovač prepol prepínač späť na nulu

1.3.4. Nastavenie teploty

Účelom termostatu (obr. 3) je udržiavať teplotu v saune na požadovanej úrovni držať. Experimentovaním môžete určiť ktoré nastavenie vám najviac vyhovuje.

Začnite s najvyšším nastavením. ak teplota počas sauny je príliš vysoká zvyšuje sa, mierne otočte spínačom proti smeru hodinových ručičiek v smere hodinových ručičiek. Všimnite si, že v hornej časti Teplotný rozsah aj malé zmeny výrazne ovplyvňujú teplotu v saune.

1.4.

Preto vzduch v saune pri zahrievaní vysychá voda by sa mala nanášať na horúce kamene ohrievača sauny, aby sa dosiahla pohodlná úroveň vlhkosti byť obsadené. Účinky tepla a Páry sa líšia od človeka k človeku - metódou pokusov a omylov nájdete úroveň teploty a vlhkosti, ktorá vám najviac vyhovuje sú vhodné.

POZORNOSŤ! Kapacita saunovej naberačky by mala najviac 0,2 l. Na kamene by sa nemalo nalievať veľké množstvo vody naraz inak varenie pri odparovaní voda by mohla striekať na kúpajúcich sa. Pozor Dávajte tiež pozor, aby ste na kamene neliali vodu, keď je niekto v ich blízkosti. z horúca para môže spôsobiť popáleniny. **POZORNOSŤ!** Ako infúzna voda sa má používať iba voda. použitie, ktoré spĺňa požiadavky na kvalitu Voda pre domácnosť sa stretla (tabuľka 1). V infúznej vode sa môžu používať iba vonné látky určené na tento účel. Postupujte podľa pokynov na obale.

Water property Wassereigenschaft	Effect Wirkung	Recommendation Empfehlung
Humus concentration Humusgehalt	Colour, taste, precipitates Farbe, Geschmack, Ablagerungen	< 12 mg/l
Iron concentration Eisengehalt	Colour, odour, taste, precipitates Farbe, Geruch, Geschmack, Ablagerungen	< 0,2 mg/l
Hardness: most important substances are manganese (Mn) and lime, i.e. calcium (Ca). Wasserhärte: Die wichtigsten Stoffe sind Mangan (Mn) und Kalk, d.h. Kalzium (Ca).	Precipitates Ablagerungen	Mn: < 0,05 mg/l Ca: < 100 mg/l
Chlorinated water Gechlortes Wasser	Health risk Gesundheitsschädlich	Forbidden to use Darf nicht verwendet werden
Seawater Salzwasser	Rapid corrosion Rasche Korrosion	Forbidden to use Darf nicht verwendet werden

Table 1 Water quality requirements

1.5. Pokyny pre sauny

- Pred saunovaním umyte.
- Zostaňte v saune tak dlho, ako o tom premýšľate cítiť sa pohodlne.
- Zabudnite na všetok stres a relaxujte.
- Dobrá sauna zahŕňa zváženie pre ostatných kúpajúcich sa
Nebudte zbytočne hluční
rušiť.
- Neprenasledujte so sebou ostatných
veľa infúzií.
- Medzitým nechajte zohriatu pokožku vychladnúť. Ak ste zdraví a môžete, choďte plávať.
- Umyte sa po saune.
- Odpočívajte, kým nebudete v rovnováhe cítiť. Pite čistú vodu alebo a
Nealkoholický nápoj na zvýšenie rovnováhy tekutín
Stabilizovať

1.6. Upozornenie

- Dlhý pobyt v horúcej saune vedie k zvýšeniu telesnej teploty, čo môže byť nebezpečné.
- Dajte si pozor na horúcu saunovú rúru. Kamene a kryt sa veľmi zahreje a môže spáliť pokožku.
- Uchovávajte deti mimo dosahu rúry.
- Deti, hendikepované, choré a slabé nesmie byť ponechaný sám v saune.
- Zdravotné obmedzenia týkajúce sa Sauny by sa mali konzultovať s lekárom vôľa.
- O saunách pre malé deti by ste mali poradiť sa s materským poradenským centrom.
- Nechoďte do sauny, ak ste pod vodou vplyv omamných látok (alkohol, lieky, drogy atď.).
- Nikdy nespíte vo vyhrievanej saune.
- Morské a vlhké podnebie môže hrdzaviť kovové povrchy saunového ohrievača.
- Nepoužívajte saunu na sušenie odevov alebo bielizne kvôli riziku požiaru.
okrem toho môžu byť elektrické spotrebiče môže dôjsť k poškodeniu vysokej vlhkosti.

1.7. Poruchy

Nebezpečenstvo! Všetku údržbu musí vykonávať kvalifikovaný technický personál vôľa.

Rúra sa nezohrieva.

- Skontrolujte poistky rúry sú v dobrom stave.
- Skontrolujte, či je pripojovací kábel zapojené (3.3.).
- Nastavte časovač na časť "zapnuté" (1.3.1.).
- Nastavte termostat na vyššiu hodnotu Nastavenia (1.3.4.).
- Skontrolujte, či existuje ochrana proti prehriatiu sa začalo. Časovač beží, ale kachle sa nezohrievajú. (3.5.

- Skontrolujte poistky rúry sú v dobrom stave.
- Uistite sa, že keď keď je rúra zapnutá, všetky vykurovacie telesá sú osvetlené.
- Nastavte termostat na vyššiu hodnotu Nastavenia (1.3.4.).
- Skontrolujte, či je výkon pece je dostatočná (2.3).
- Skontrolujte kamene saunovej pece (1.1.).
Príliš tesná hromada kameňov, ktoré Usadzovanie kameňov v priebehu času a nesprávne Druhy kameňov môžu obmedziť prúdenie vzduchu cez Rúra prekáža, čo vedie k zníženiu vykurovacie káble.
- Uistite sa, že je zabezpečené vetranie Saunová kabína je správne nastavená (2.2.).

Saunová kabína sa rýchlo zahreje, ale Teplota kameňov je nedostatočná. že hore preteká kamenná voda.

- Nastavte termostat na nižšiu hodnotu Nastavenia (1.3.4.).
- Skontrolujte, či výkon rúry nie je príliš vysoký je vysoká (2.3.).
- Uistite sa, že je zabezpečené vetranie Saunová kabína je správne nastavená (2.2.).

Saunová kabína sa zahrieva nerovnomerne.

- Uistite sa, že je rúra v rúre správna výška. Pec Sauna sa dá najlepšie vyhrievať, keď 100 mm nad podlahou. a maximálna montážna výška je 200 mm. (3.2.)

Panely a iné materiály vedľa kachlí rýchlo sčernie.

- Skontrolujte požiadavky na sú dodržané bezpečnostné vzdialenosti (3.1.).

- Skontrolujte kamene saunovej pece (1.1.). Príliš tesná hromada kameňov, ktoré Usadzovanie kameňov v priebehu času a nesprávne Druhy kameňov môžu obmedziť prúdenie vzduchu cez Upchatie rúry, čo vedie k prehriatiu rúry okolité materiály.

- Pozri aj oddiel 2.1.1.

Rúra vydáva pachy.

- Pozri oddiel 1.2.
- Horúca rúra môže vytvárať zápach vo vzduchu zvýšenie, ale nie cez saunu alebo samotnú pec. Príklady: farba, lepidlo, olej, korenie.

Rúra vydáva hluk.

- BC: Časovač je mechanický zariadenie, a preto spôsobuje tikanie hluk počas normálnej práce. Tikanie znie, aj keď kachle nie sú je zapnutý, preskúmať Pripojte časovač.
- Niekedy dochádza k náhlemu praskaniu praskanie kameňov pod vplyvom tepla.
- Natiahnutie častí rúry v dôsledku tepla Môže vydávať hluk, keď sa rúra zahreje dôvod

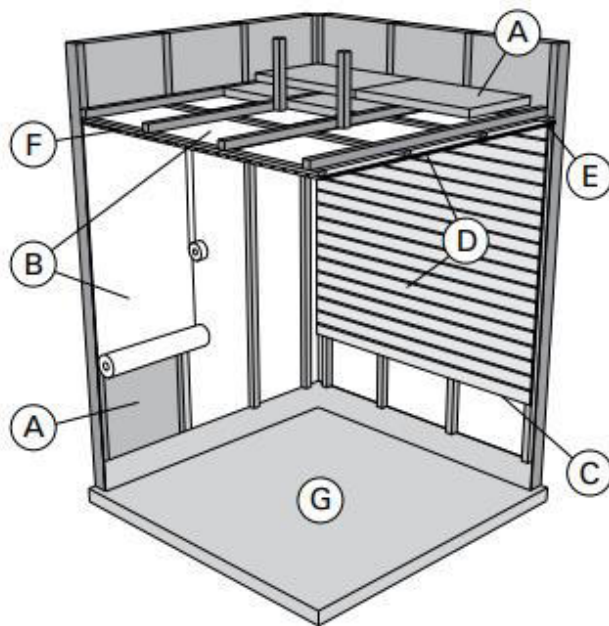

ure 4.
bildung 4.

- A. Izolačná vlna, hrúbka 50-100 mm. Saunová kabína musí byť starostlivo izolovaná, aby rúra nemusí produkovať príliš veľa energie.
- B. Ochrana proti vlhkosti, napr. hliníkový papier a lesklá strana papiera musí ísť do sauny dokázať. Švy utesnite hliníkovou páskou.
- C. Približne 10 mm medzera medzi ochranou proti vlhkosti a podšívku (odporúčanie).
- D. Lhká panelová doska s hrúbkou 12-16 mm. pred Začiatok elektroinštalácie obloženia a skontrolujte výstuhy v stenách potrebných pre kachle a lavice.
- E. Približne 3 mm medzera medzi obložením stien a stropov •
- Otázka: Nadmorská výška sauny je zvyčajne 2100-2300 mm. Minimálna výška závisí od kachlí (pozri tabuľku 2). Vzdialenosť medzi horná lavica a strop by mali byť max byť 1200 mm.
- G. Keramické a tmavé podlahové krytiny Použite cementovú suspenziu. Častice unikajúce zo saunových kameňov a nečistôt vo vode môžu poškodiť citlivé podlahy zmena farby alebo poškodenie.

POZORNOST! Opýtajte sa orgánov, ktorá časť žiaruvzdornú stenu je možné izolovať. Použité dymovody sa nesmú izolovať.

POZORNOST! Lhké ochranné kryty pripevnené priamo k stene alebo stropu predstavujú nebezpečenstvo požiaru.

2.1.1. Sčernanie saunových stien

Je celkom normálne, ak existujú drevené povrchy časom sa v saune zmení farba. Sčernanie je zrýchlený

- Slnéčné svetlo
- Teplo rúry
- Ochrana obloženia stien (s malým množstvom tepelná odolnosť)
- Jemné častice uvoľňované do vzduchu z rozpadajúcich sa saunových kameňov.

2.2. Vetrание saunovej kabíny

Vzduch v saune by sa mal meniť šesťkrát za hodinu. Obr. 5 znázorňuje rôzne možnosti vetrania sauny.

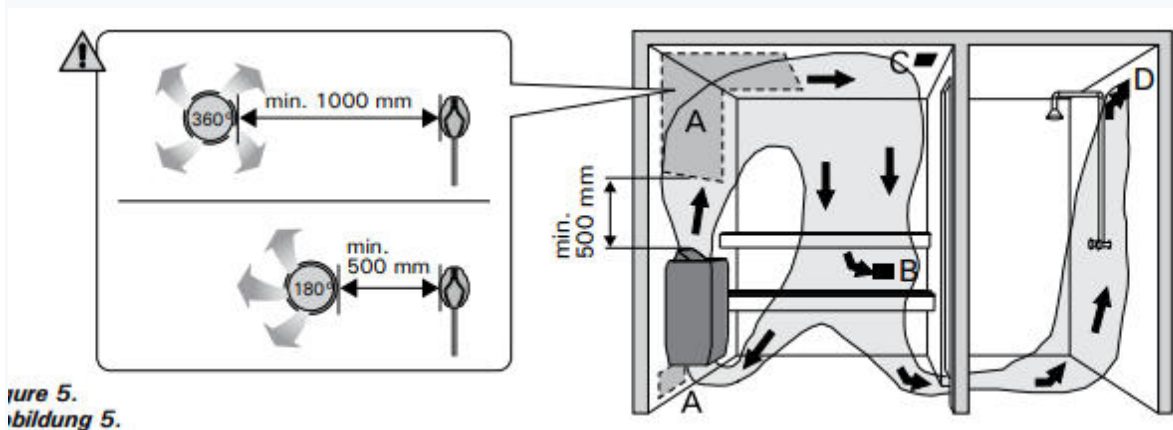

Figure 5.
Abbildung 5.

A. Prívod vzduchu. V prípade mechanického odvzdušňovania umiestnite nad kachle prívod vzduchu. V prípade gravitačného vetrania prívod vzduchu pod alebo vedľa pripevnite k rúre. Priemer potrubia na prívod vzduchu musí byť 50 - 100 mm.

BC-E: Neumiestňujte prívod vzduchu tak, aby bol snímač teploty sa ochladzuje (na pripojenie snímač teploty, pozrite si pokyny na inštaláciu riadiacej jednotky)!

B. Prieduch. inštalovať vetranie v blízkosti podlahy, čo najďalej od rúry. Priemer odvzdušňovacieho potrubia by mal byť dvojitý

byť také veľké ako v prívode vzduchu.

C. Voliteľné vetranie na sušenie (počas kúrenie a kúpeľňa zatvorené). Saunová plechovka je možné sušiť aj pri otvorených dverách.

D. Ak je na toalete vetrací otvor, medzera pod dverami sauny musí byť min. byť 100 mm. Mechanické odvzdušňovanie je povinnosť.

2.3. Výstup z pece

Ak sú stena a strop obložené a dostatočné sú izolované, výstupný výkon závisí od ohrievač podľa objemu sauny. Nie je izolovaný Steny (kameň, sklenené tvárnice, sklo, betón, dlaždice) zvýšiť požadovaný výkon pece. Každý meter štvorcový neizolovanej steny zodpovedá ďalším 1,2 m³ objem sauny. Saunová kabína 10 m³ s Napríklad sklenené dvere zodpovedajú výkonu 12 m³ sauna. V prípade drevených stien vynásobte objem sauny číslom 1,5. V tabuľke 2 vyberte správny výkon pece.

2.4. Hygiena saunovej kabíny

Aby sa lavičky nepotili, používajte plážové uteráky chrániť.

Lavičky, steny a podlaha sauny minimálne umyte každých šesť mesiacov. Použite čistiaci prostriedok kefy a sauny.

Utrite prach a nečistoty z rúry vlhkou handričkou utierať. Usadeniny vodného kameňa na sporáku s 10 % Odstráňte kyselinu citrónovú a opláchnite.

3.1. Pred montážou

Pred inštaláciou saunového ohrievača si prečítajte Montážne pokyny a skontrolujte nasledujúce veci:

- Má byť v prevádzke saunový ohrievač?

a typ vhodný pre saunovú kabínu? a

Objemové hodnoty v tabuľke 2 nesmú obsahovať ani jednu z týchto hodnôt.

by mali byť podrezané.

- Je sieťové napätie vhodné pre saunové kachle?
- Miesto inštalácie kachlí spĺňa minimálne bezpečnostné vzdialenosti znázornené na obrázku 6 a v tabuľke 2.

Tieto vzdialenosti sa musia prísne dodržiavať pretože odchýlka vytvára nebezpečenstvo požiaru.

V saune môže byť inštalovaný iba jeden saunový ohrievač vôľa

Heater Ofen	Out- put Leis- tung	Sauna room Saunakabine			Electrical connections Elektroanschlüsse				
		Cubic vol. Rauminhalt		Height Höhe	400 V 3N~ Connecting cable Anschlusskabel		Fuse Sicherung	230 V 1N~ Connecting cable Anschlusskabel	
Width/Breite • BC 480 mm • BC-E 450 mm Depth/Tiefe 310 mm Height/Höhe 540 mm Weight/Gewicht 11 kg Stones/Steine max. 20 kg		> 2.3.			See fig. 8. The measurements apply to the connecting cable only! Siehe Abbildung 8. Die Messungen beziehen sich ausschließlich auf das Anschlusskabel!				
	kW	min. m ³	max. m ³	min. mm	mm ²	A	mm ²	A	mm ²
BC45/BC45E	4,5	3	6	1900	5 x 1,5	3 x 10	3 x 2,5	1 x 20	4 x 0,25
BC60/BC60E	6,0	5	8	1900	5 x 1,5	3 x 10	3 x 2,5	1 x 35	4 x 0,25
BC80/BC80E	8,0	7	12	1900	5 x 2,5	3 x 16	3 x 6	1 x 35	4 x 0,25
BC90/BC90E	9,0	8	14	1900	5 x 2,5	3 x 16	3 x 10	1 x 50	4 x 0,25

Table 2. Installation details

Tabelle 2. Montageinformationen

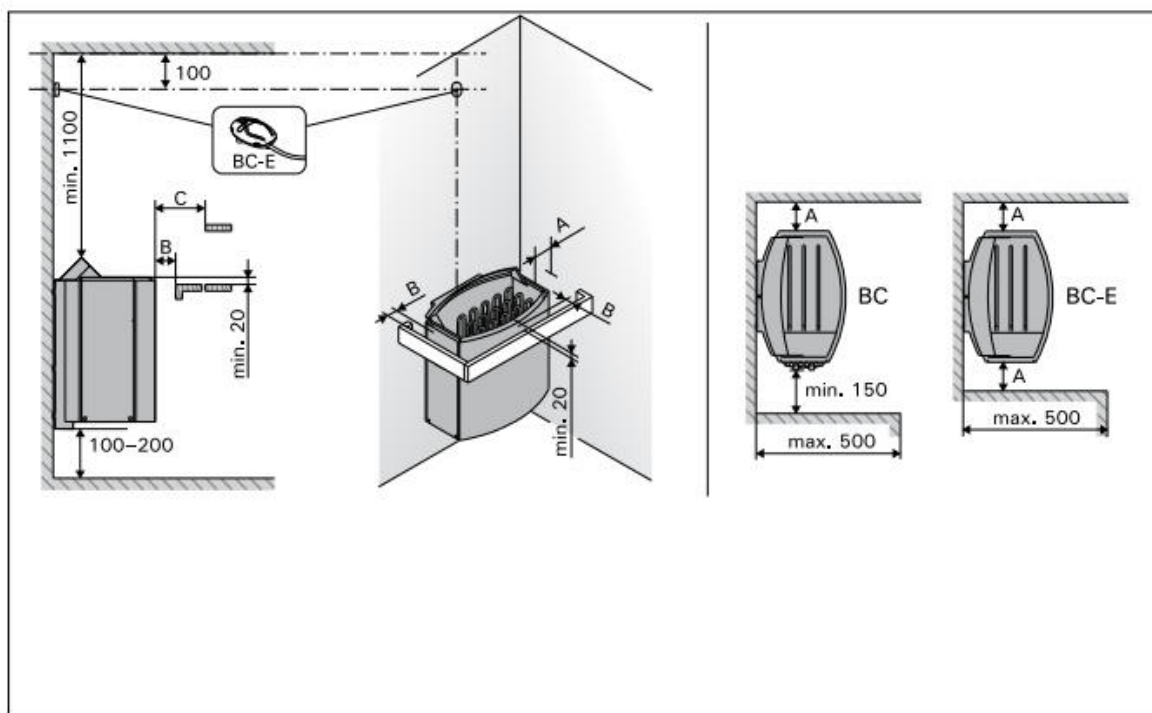

Figure 6. Safety distances (all dimensions in millimeters)

Abbildung 6. Sicherheitsmindestabstände (alle Abmessungen in Millimetern)

3.2. Upevnenie saunového ohrievača na stenu

Pozri obrázok 7.

1. Pred montážou odstráňte oba ochranné kartóny!

2. Pripevnite montážny rám pomocou dodané skrutky na stenu.

POZORNOST! Na miestach, kde sú pripevnené upevňovacie skrutky musí byť za panelmi ako podpera, napr. umiestnená doska, v ktorej sú skrutky pevne utiahnuté sedieť. Ak za ním nie sú žiadne panely Dosky sú umiestnené, môžu byť aj v prednej časti sú pripevnené panely.

3. Saunové kachle je možné ovládať cez Pravák alebo lavák inak na byť namontované na stene. Presvedčiť sa Správne zaistené upevňovacie priechodky

visieť na sedenie.

4. Zdvihnite saunový ohrievač k rámu stena, za ktorou sú zavesené upevňovacie háčiky v spodnej časti. Postavte sa za okraj tela ohrievača sauny. Príšť. Odskrutkovanie hornej časti saunový ohrievač do montážneho rámu.

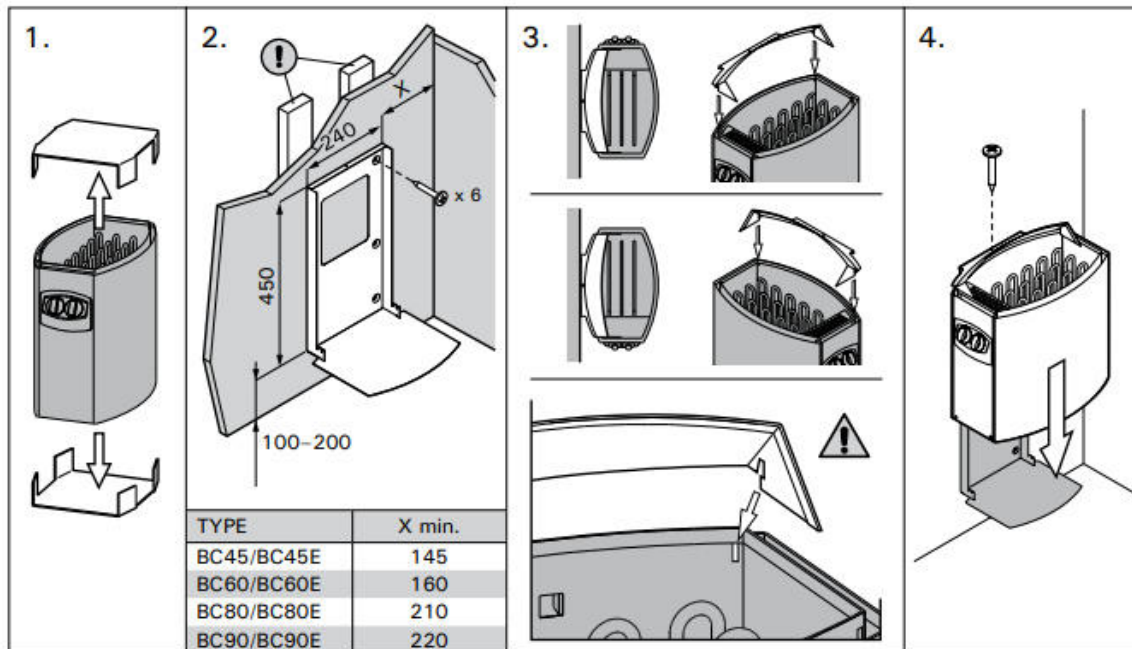

Figure 7. Fastening the heater on a wall (all dimensions in millimeters)
Abbildung 7. Befestigung des Saunaofens an der Wand (alle Abmessungen in Millimetern)

3.3. Elektrické prípojky

Prípojenie saunového ohrievača k zdroju napájania je povolené môže vykonávať len autorizovaný elektrikár v súlade s platnými predpismi.

- Saunový ohrievač je polotesne pripojený k svorkovnici (Obr. 8: A) pripevnené k stene sauny. a Rozvodná skrinka musí byť odolná proti striekajúcej vode a môže umiestnené najviac 500 mm nad podlahou.
- Ako pripojovací kábel sa používa gumový kábel typu H07RN-F alebo zodpovedajúci kábel (obr. 8: B). POZORNOSŤ! Káble izolované z PVC nie sú povolené kvôli ich nízkej kvalite Tepelná odolnosť nie je ako spojovací kábel je možné použiť saunový ohrievač.
- Ak je konektor alebo montážne káble viac ako 1000 mm nad vozovkou prietok do saunových alebo saunových stien, pri zatažení musí odolať teplote najmenej 170 °C (napr. SSJ). Elektrické zariadenia vyššie ako 1000 mm od saunovej podlahy musí byť pripojené na použitie povolené pri teplote okolia 125 °C (Poznámka T125).
- Okrem sieťovej prípojky sú saunové kachle BC vybavené terminálom (P), ktorý ponúka možnosť ovládania elektrického vykurovania (obr. 10). Rúra preberá olovo so zapnutou reguláciou napätia.

Ovládací kábel pre elektrický ohrievač sa stáva spojovacím boxom saunového ohrievača položené a odtiaľ gumovým káblom rovnakej hrúbky ako svorkovnica saunový ohrievač. Pri zatváraní veka buďte opatrní distribučné skrine, že kryt je uzavretý úplne zatvorené. Ak nie veko správne môže voda prúdiť do rozvodnej skrinky. ilustrácia

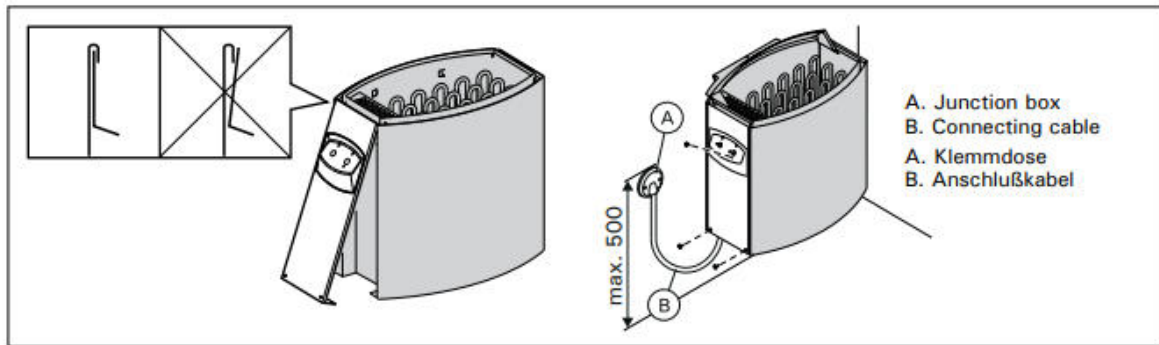

Figure 8. Closing the cover of the connection box (all dimensions in millimeters)
Abbildung 8. Das Verschließen des Anschlusskastens (alle Abmessungen in Millimetern)

3.3.1. Izolačný odpor elektrického saunového ohrievača
 Počas konečnej revízie elektroinštalácie pri meraní izolačného odporu dochádza k "úniku", ktorý je spôsobený vlhkosťou zo vzduchu do izolačného materiálu vyskytol sa výskyt vykurovacích odporov (počas skladovania a doprava). Vlhkosť uniká z odporov po dvoch rozsvičkách. Vypnite elektrické napájanie saunového ohrievača nie cez chránič prúdu.

3.4. Pripojenie riadiacej jednotky a Senzor (BC-E)
 Podrobné pokyny na montáž riadiacej jednotky na stenu sú súčasťou riadiacej jednotky daný. Teplotný senzor je pripevnený k stene sauny nad vyhrievacím telesom sauny, 100 mm pod ním pripevnené k stropu na osi v smere šírky saunovej pece. Obrázok 6. Nepripínajte prívod vzduchu tak, aby bol Snímač teploty sa ochladzuje. Obrázok 5

3.5. Obnovte ochranu proti prehriatiu
 Ak je teplota v saune nebezpečná prudko stúpa, prehriatie ochrany sa zlomí napájanie pece je trvalé. Ochrana proti prehriatiu je možné resetovať po ochladení kachlí.

Bc

Tlačidlo reset je umiestnené v skrinke na pripojenie rúry (obr. 9).
iba jeden

Takéto práce môžu vykonávať osoby oprávnené vykonávať elektroinštaláciu.

Pred stlačením tlačidla príčiny

Poruchu je možné zistiť:

- Sú kamene v saunovej peci zaklínené alebo krehké?
- Má saunový ohrievač zapnutý na dlhú dobu a nebol použitý?
- Je snímač termostatu nesprávne zapnutý miesto alebo vada?
- Bol saunový ohrievač vystavený silným nárazom?

BC-E

Pozri návod na použitie a inštaláciu riadiacej jednotky •

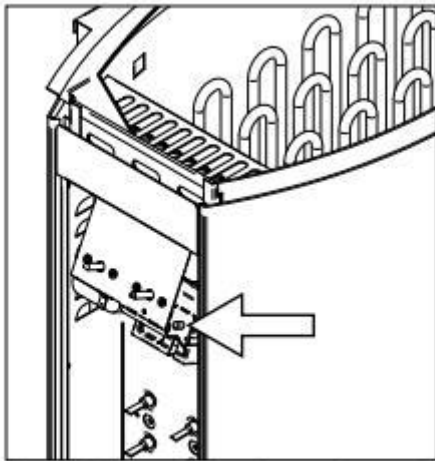

Figure 9. Reset button for overheat protector
Abbildung 9. Rücksetzknopf des Überhitzungsschutzes

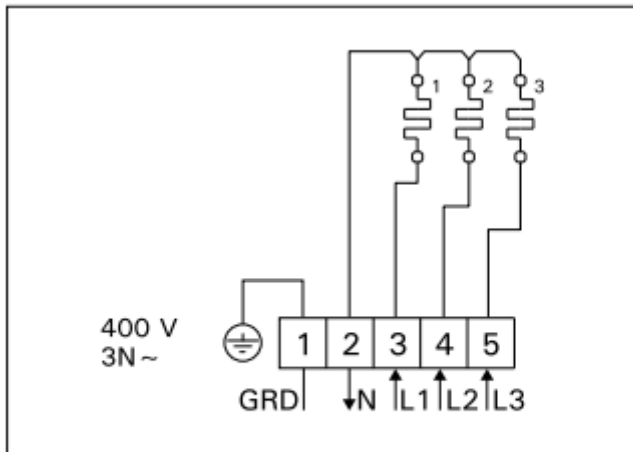

Figure 11. Electrical connections of BC-E heater
Abbildung 11. Elektroanschlüsse des Saunaofens BC-E

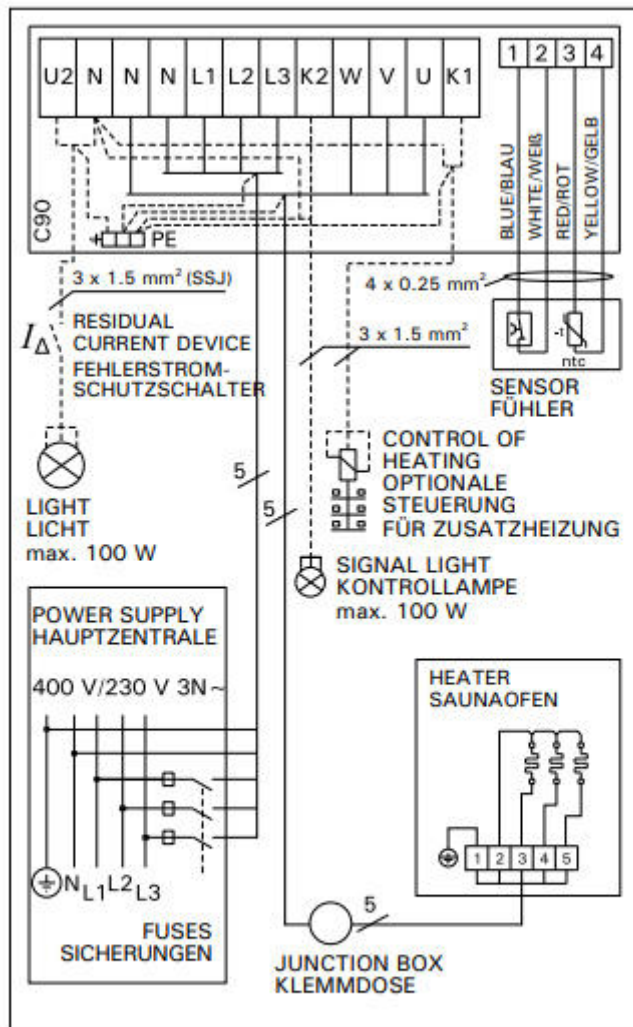
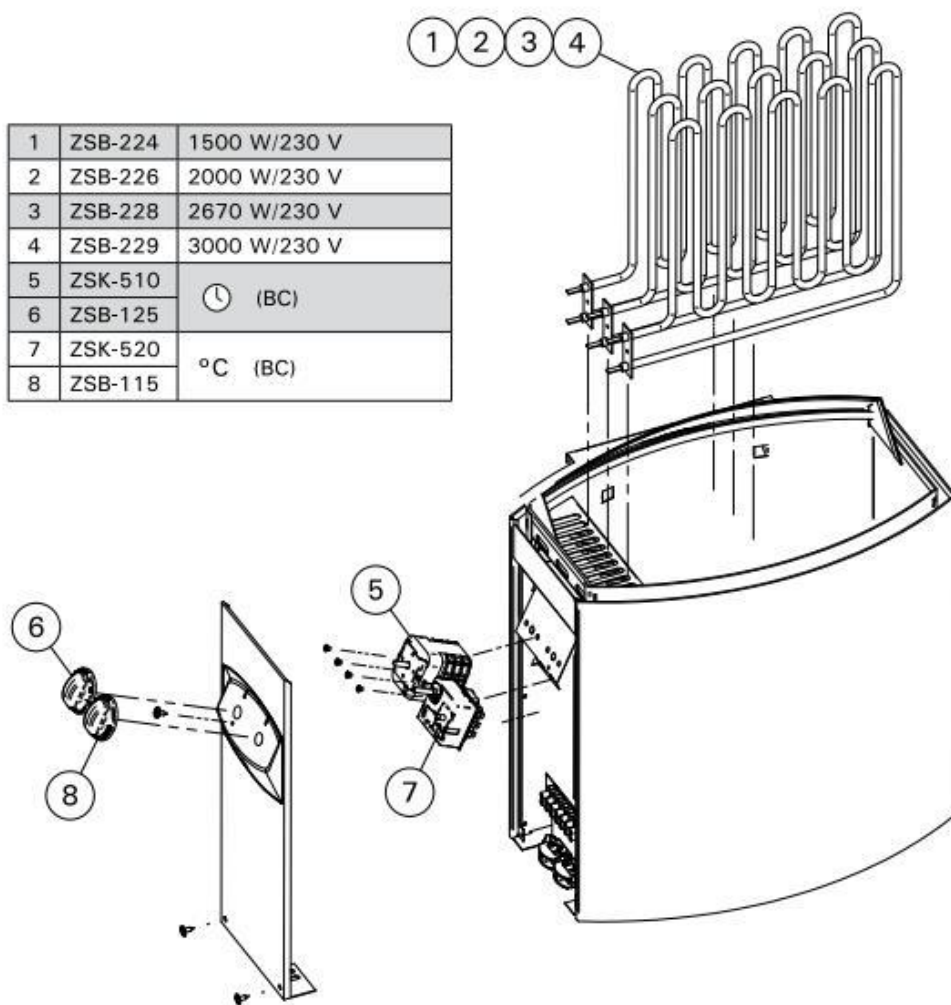

Figure 12b. 3-phase electrical connections of control unit C90 and BC-E heater
Abbildung 12b. 3-phasiger Elektroanschlüsse des Steuergerät C90 und des Saunaofens BC-E

Náhradné diely

1	ZSB-224	1500 W/230 V
2	ZSB-226	2000 W/230 V
3	ZSB-228	2670 W/230 V
4	ZSB-229	3000 W/230 V
5	ZSK-510	⌚ (BC)
6	ZSB-125	⌚ (BC)
7	ZSK-520	°C (BC)
8	ZSB-115	°C (BC)



Návod k použití

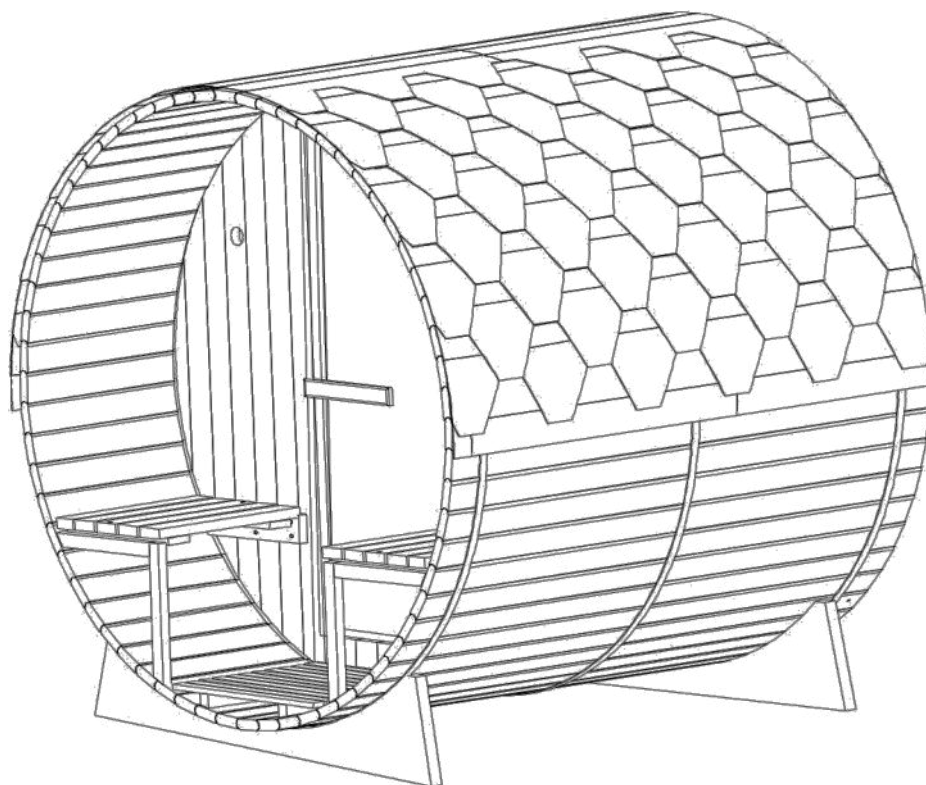

Infračervené dělá život zdravějším

Doporučení

Před prvním použitím sauny si pečlivě přečtěte tyto pokyny.

Doporučujeme jej uložit na bezpečném místě, abyste jej mohli v budoucnu znovu použít.

- Dřevo je živý prvek. Pro zachování původního vzhledu je důležité dřevo zvenku ošetřit proti vlhkosti.
- Umístěte saunu na zcela rovný a tvrdý povrch.
- Nepoužívejte tekuté čisticí prostředky. Před čištěním saunu vypněte a použijte vlhký hadřík.
- Chraňte napájecí kabel sauny, aby nedošlo k jeho přimáčknutí nebo přiskřípnutí.
- Před výměnou určitých součástí se ujistěte, že jsou specifikovány výrobcem nebo mají stejné vlastnosti jako originální díly. Nesprávná výměna může způsobit požár, zkrat nebo poškození sauny. Důrazně doporučujeme, abyste se obrátili na kvalifikovaného technika.
- Abyste předešli riziku popálení nebo úrazu elektrickým proudem, nepoužívejte kovové nástroje
- Do sauny se nesmí vodit zvířata.
- Nenechávejte zapnutou saunu bez dozoru.
- Nenechávejte saunu zapnutou déle než 3 hodiny v kuse, aby nedošlo k předčasnému poškození zařízení. Po 3 hodinách nepřetržitého používání saunu alespoň na jednu hodinu vypněte.
- Doporučujeme neinstalovat na dveře sauny uzamykací systém.
- Před připojením sauny ke zdroji napájení zkontrolujte, zda jsou elektronické části správně připojeny.

Bepečnost

DŮLEŽITÉ!

Před nastavením a používáním sauny si pečlivě přečtěte bezpečnostní pokyny.

Pokyny jsou důležité pro vaši bezpečnost, proto je prosím přísně dodržujte.

Dávejte pozor na hypertermii, úpal nebo vyčerpání z horka, které může být způsobeno nebo zhoršeno nedodržením bezpečnostních pokynů. Příznaky zahrnují horečku, zrychlený puls, závratě, mdloby, letargii a necitlivost v celém těle nebo v jeho částech. Účinky jsou: snížené vnímání tepla, neznalost hrozícího nebezpečí, bezvědomí.

Saunu nesmí používat:

- Děti do 6 let.
- Lidé se silnými reakcemi na sluneční světlo.
- Starší nebo zdravotně postižení lidé.
- Lidé s již existujícími zdravotními potížemi, jako je srdeční onemocnění, vysoký nebo nízký krevní tlak, oběhové problémy nebo cukrovka, bez předchozí lékařské rady.
- Těhotná žena. Nadměrná teplota může ohrozit plod.
- Lidé trpící dehydratací, otevřenými ranami, onemocněním očí, popáleninami nebo úpalem.

Děti od 6 do 16 let mohou saunu používat za předpokladu, že jsou pod neustálým dohledem odpovědné dospělé osoby a teplota nepřesáhne 60°C.

Pokud máte zdravotní problémy, užíváte léky nebo máte poranění svalů a vazů, můžete saunu používat pouze po předchozí konzultaci a schválení lékařem.

Pokud máte chirurgické implantáty, nesmíte saunu používat bez předchozí konzultace a schválení lékařem.

Nepoužívejte saunu po namáhavé činnosti.

Počkejte 30 minut, než se vaše tělo ochladí.

Netrávte v sauně najednou více než 40 minut.

Před ani během sezení nekonzumujte alkohol ani drogy.

Nespěte v sauně, když se používá.

Abyste předešli riziku přehřátí, zapojte saunu do dostatečně výkonné elektrické zásuvky a do stejné elektrické zásuvky nepřipojujte další elektrická zařízení.

Abyste zabránili riziku úrazu elektrickým proudem nebo poškození sauny, nepoužívejte ji:

- Během bouřky.
- Pokud je elektrický kabel poškozen, musí jej vyměnit kvalifikovaná osoba.
- Pokud se napájecí kabel přehřívá, musí jej zkontrolovat kvalifikovaná osoba.
- Pokud potřebujete vyměnit žárovku, počkejte, dokud se sauna nevypne a nevychladne.

Před připojením nebo vypnutím napájení si osušte ruce.

Nikdy nepracujte s mokřými rukama nebo nohama.

Nezapínejte nebo nevypínejte napájení nebo topení rychle, protože by to mohlo poškodit elektrický systém.

Nepokoušejte se sami opravovat saunu bez souhlasu prodejce nebo výrobce sauny.

Neautorizované pokusy o opravu ruší záruku výrobce.

V sauně nepoužívejte čisticí prostředky.







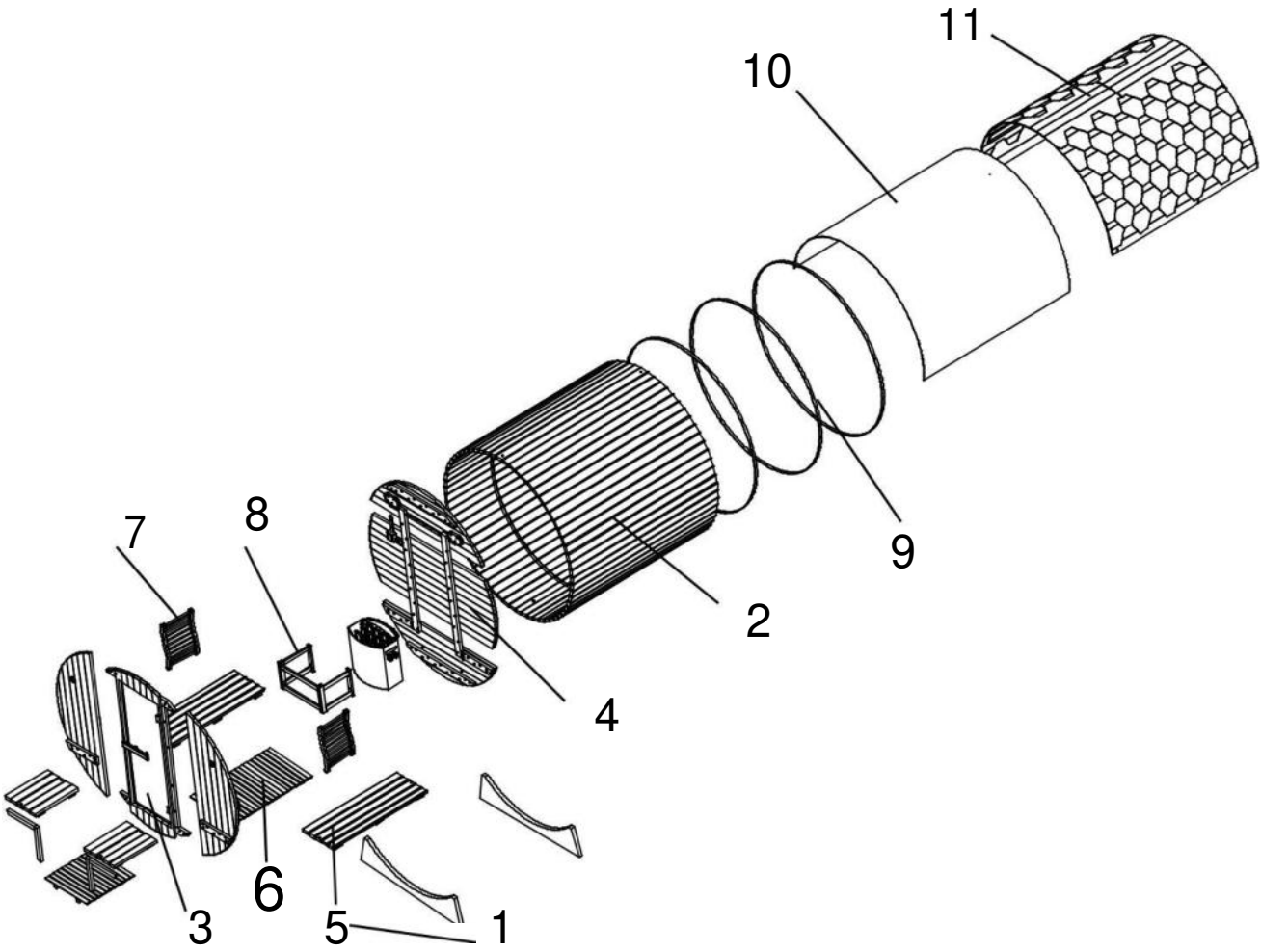



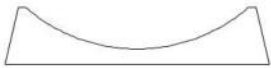

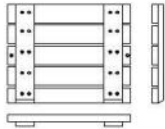

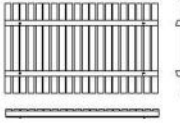

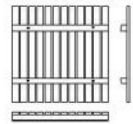
V sauně ani na ní neskládejte předměty.

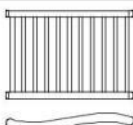
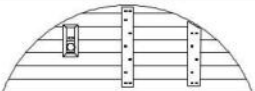
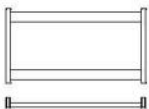
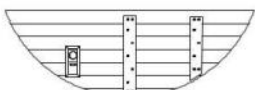
V blízkosti sauny neumísťujte hořlavé materiály nebo chemické látky.

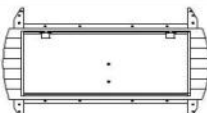

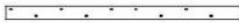
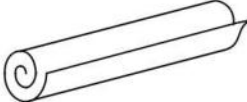

Popis sauny

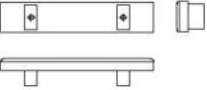
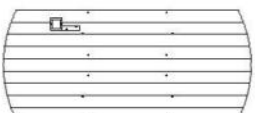
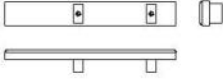
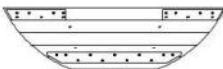
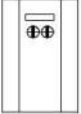
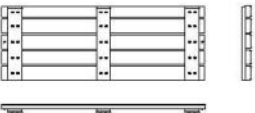
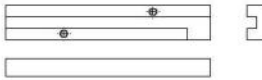



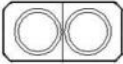
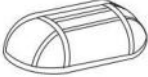

Popis sauny

1		(1400x300x33mm) 2x	5.2		(426x398x30mm) 2x
2.1		(1800x93x30mm) 2x	5.3		(532x425x50mm) 2x
2.2		(1800x93x30mm) 1x	6.1		(990x585x40mm) 1x
2.3		(1800x93x30mm) 60x	6.2		(535x585x40mm) 1x
2.4		(1800x93x30mm) 1x	7		(520x330x65mm) 2x
3.1		(1758x575x30mm) 1x	8.1		(560x300x40mm) 1x
3.2		(1650x575x30mm) 1x	8.2		(378x300x40mm) 2x
3.3		(1758x952x30mm) 1x	9		3x Pneu sudu
4.1		(1404x80x20mm) 1x	10		(3000x1800mm) 1x
4.2		(1404x80x20mm) 1x	11		(1000x320mm) 60x
4.3		(1574x488x30mm) 1x	12		(250x50x45mm) 1x
4.4		(1758x783x30mm) 1x	13		(350x50x45mm) 1x
4.5		(1574x488x30mm) 1x	14		1x Kamna
5.1		(1152x425x50mm) 2x	15		(177x80x30mm) 1x

Beschreibung Sauna

16		1x Miska na vodu	20		1x Hydrometer
17		2x Kryt osvětlení 21			1x Hodiny
18		2x Držák nápojů	22		1x Naběračka
19		1x Vědro			

							
Ø5x50	Ø4x50	Ø4x30	Ø3x35	Ø4x12	Ø6x70		
44x	20x	8x	66x	240x	2x	2x	

Než najdete vhodné místo pro saunu, přečtěte si pozorně montážní návod.

Sauna je určena výhradně pro venkovní instalaci.

Vyberte pokoj:

- V suché místnosti, na rovném a stabilním povrchu, který unese váhu sauny.
- Výška musí být taková, abyste dosáhli na strop a mohli provádět elektrické připojení a údržbářské práce.
- V blízkosti zdrojů vody, plamenů nebo hořlavých materiálů.

Praktické rady

- Vezměte prosím na vědomí, že k sestavení sauny jsou zapotřebí alespoň 3 dospělé osoby.
- Než začnete, jasně identifikujte každý panel
- Při instalaci ved'te napájecí kabel sauny tak, aby byl snadno přístupný.
- Všimněte si, že mezi jednotlivými modely jsou rozdíly.

DŮLEŽITÉ!

Zkontrolujte prosím zhloubení a průměr vrtaných otvorů, aby nedošlo k poškození dřeva.

Potřebné nářadí



Šroubovák



Metr



Tužka



Nůž



2 Klíč



Aku vrtačka



Vrták do dřeva



Imbusový klíč



Štafle



Kladivo

Montážní návod

Ø 5 x 50 20PCS

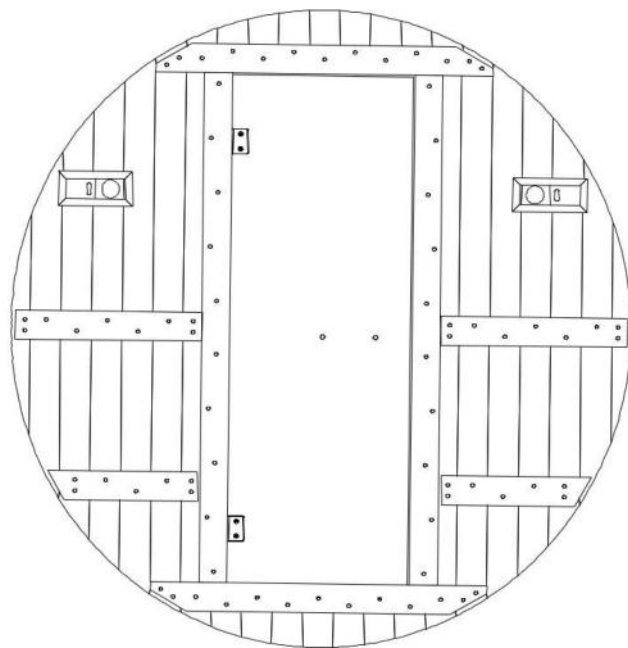
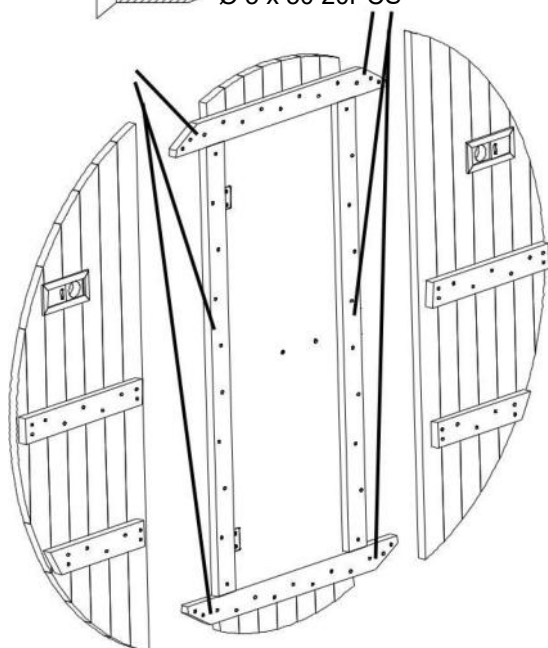

Ø 3 x 35 2PCS

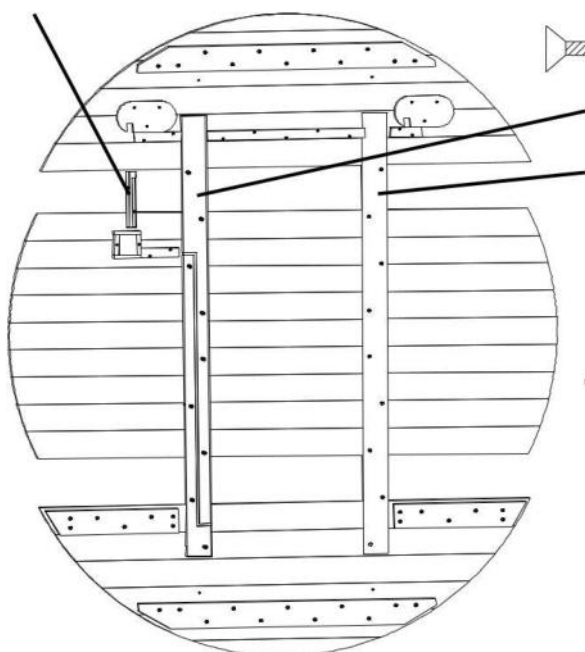

Ø 5 x 50 18PCS

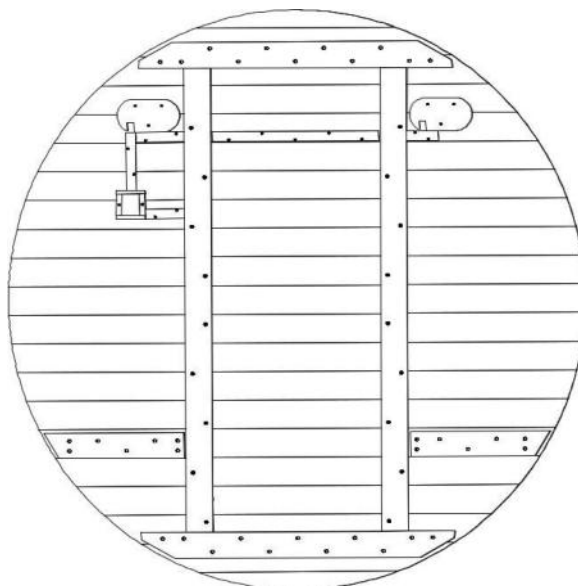

Přední a zadní stěnu je nutné nejprve sestavit jako celek.

Přední strana je rozdělena na tři části vlevo a vpravo, zadní část je rozdělena na tři části nahoře a dole.

Montážní návod

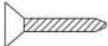
 Ø 5 x 50 2PCS

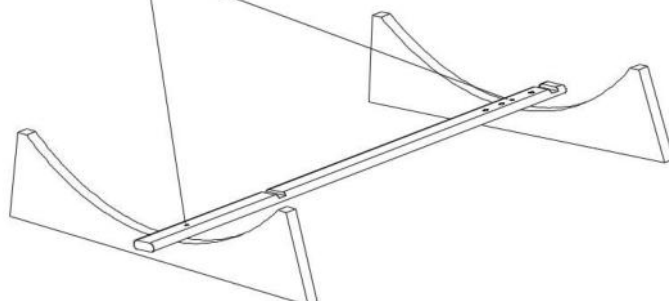

Basis

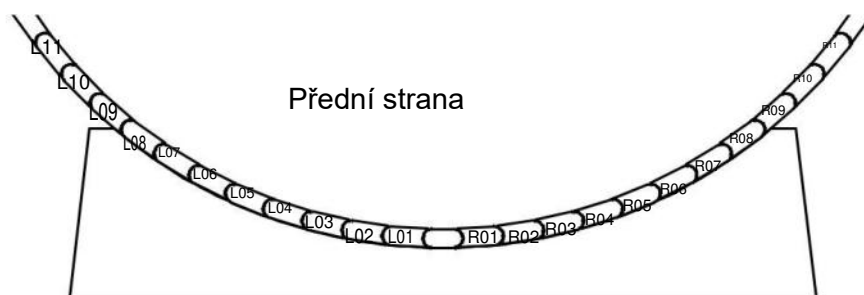
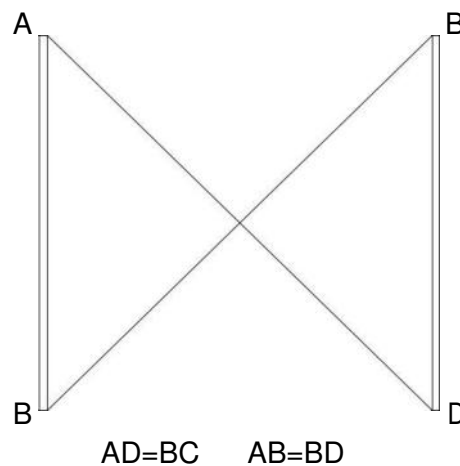

Každá lamela je očíslována a označena.

Levá strana je L01 L02 L03.....L38 zdola nahoru;

Pravá strana je R01 R02 R03.....R38 zdola nahoru.

Montážní návod

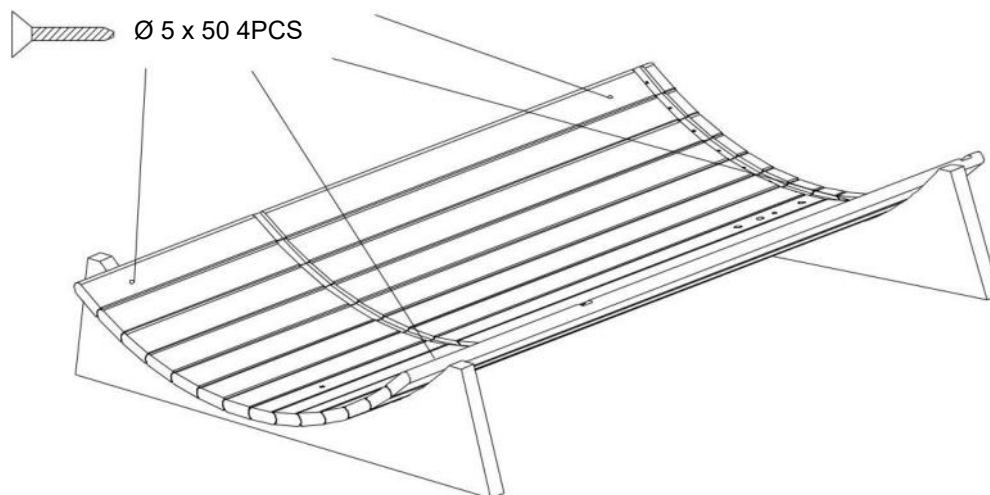

Spodní lamela

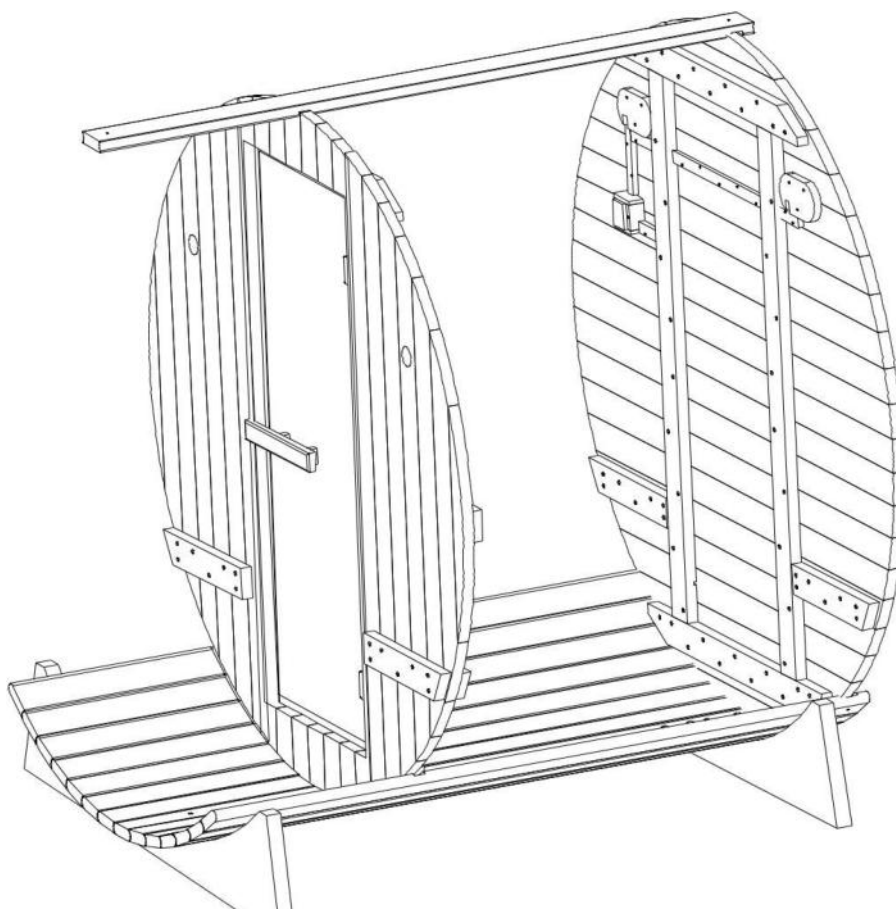

Horní lamela je dočasně instalována jako trvalé ochranné opatření během instalace.

Montážní návod

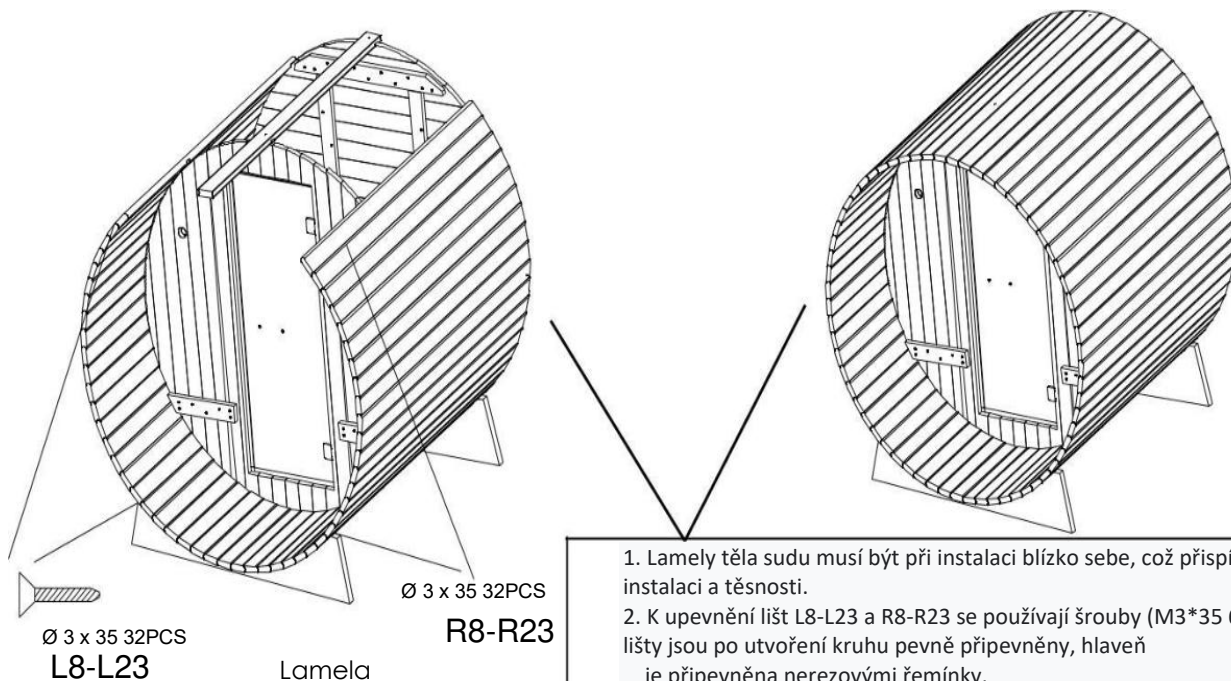

Slabé desky

V závislosti na skutečných požadavcích na instalaci, jeden nebo dva tenké pláty uprostřed sudu odstraněny po uvolnění šroubů.

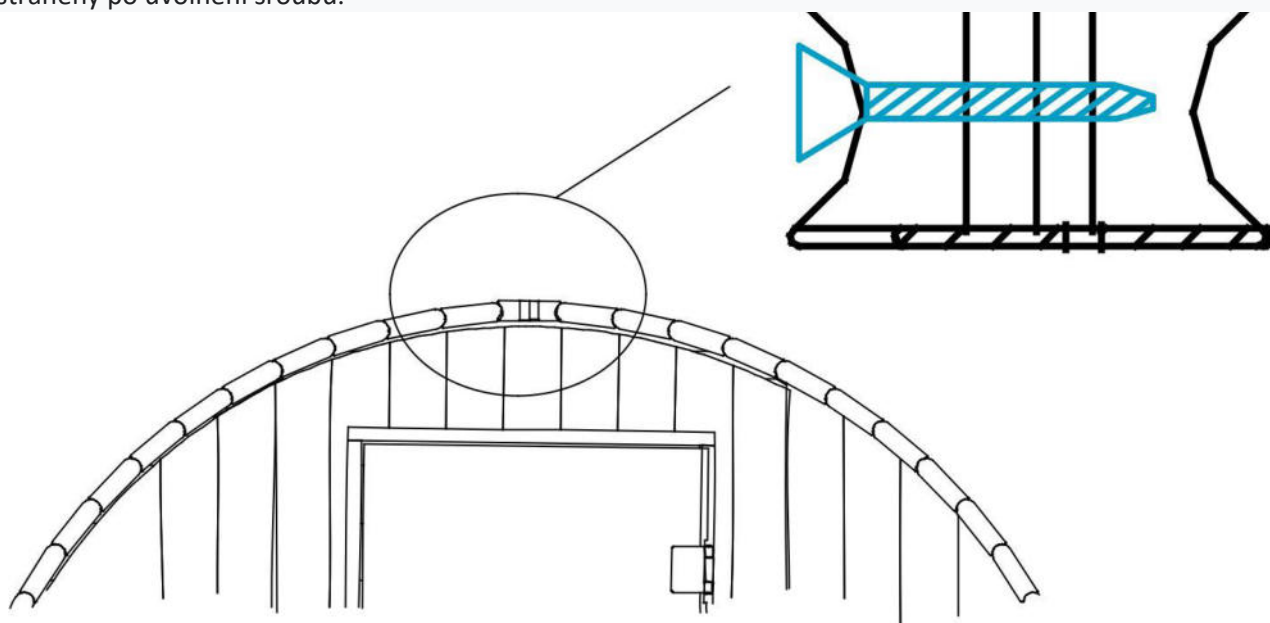

Montážní návod

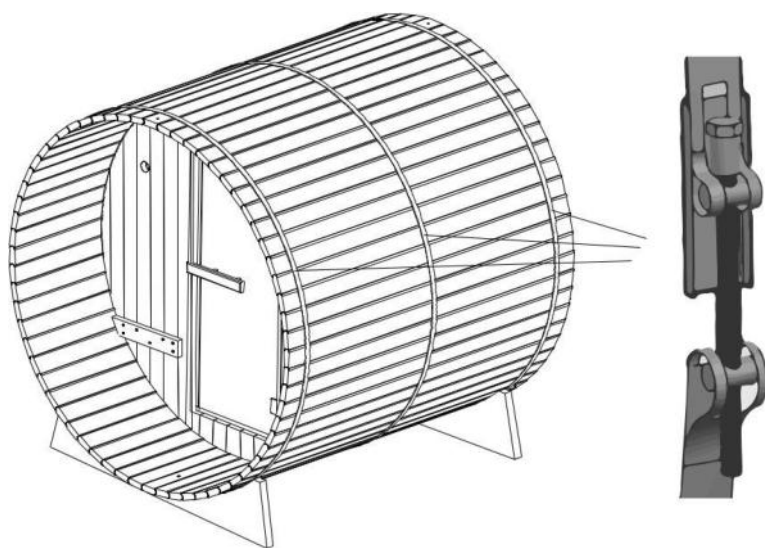

Pásky z nerezové oceli

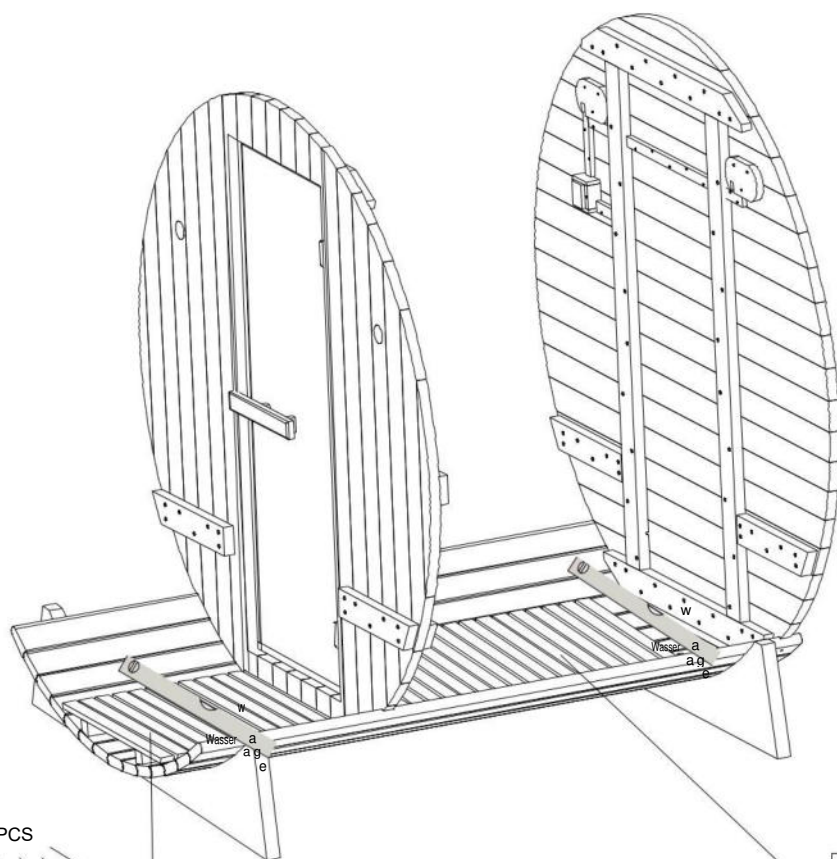

Ø 4 x 50 4PCS

Ø 4 x 50 4PCS

Podpěra nohou

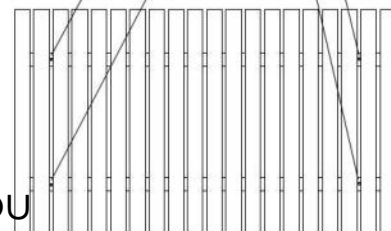
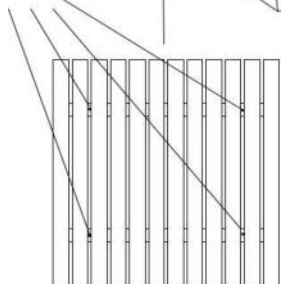

Montážní návod

Držáky vnitřních a vnějších sedacích ploch jsou předinstalovány.
Vnější základní deska vyžaduje další nosný rám a nosný rám připevňuje šrouby k lamelám.
Vnitřní základní deska nevyžaduje žádný další nosný rám.

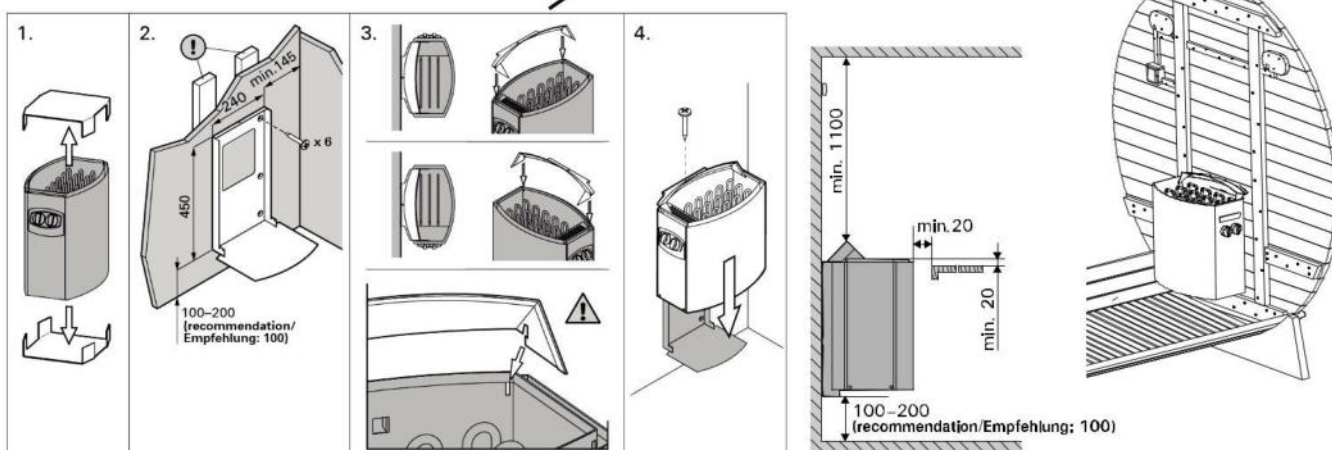
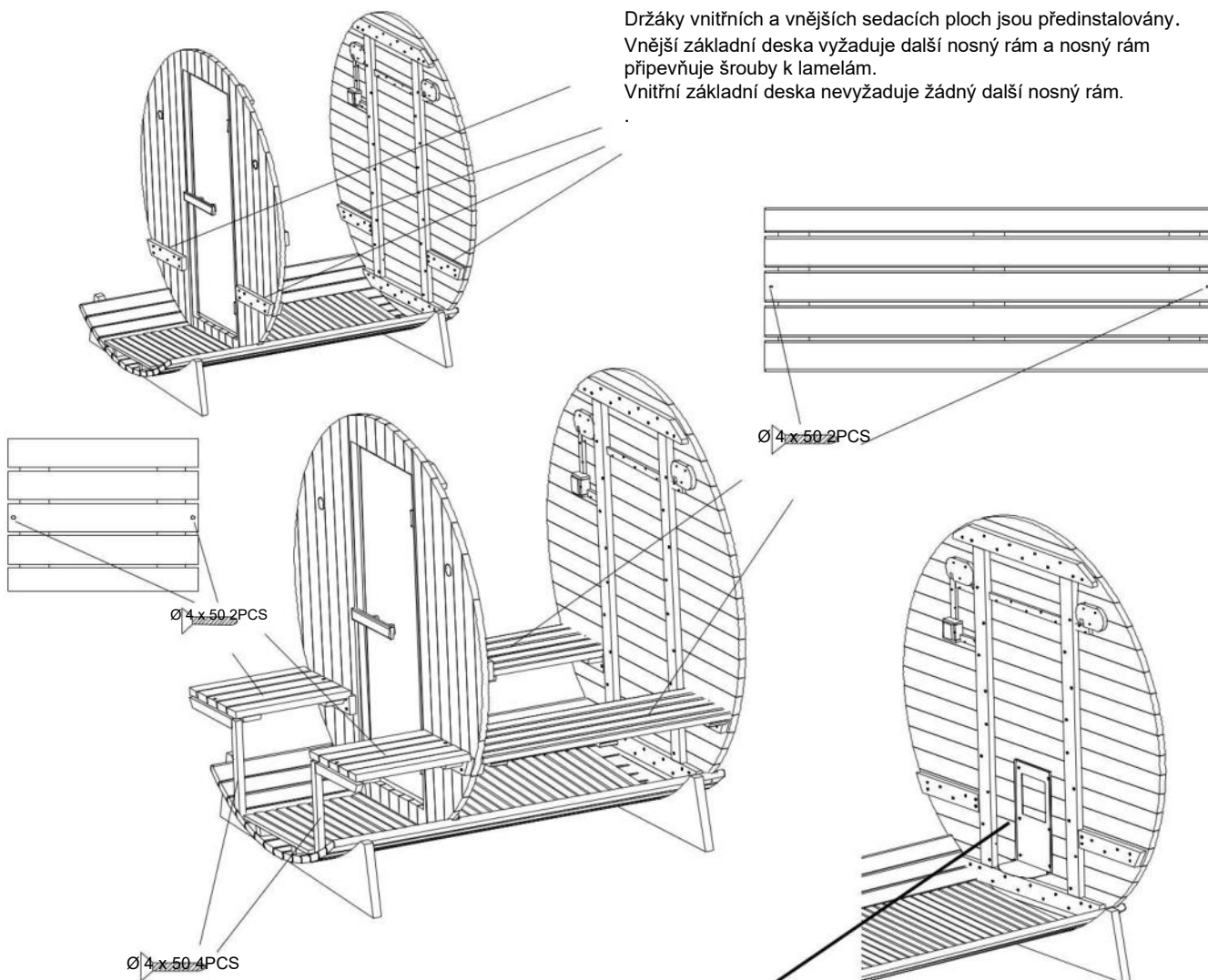

Při instalaci sauny je třeba nejprve nainstalovat nástěnný držák rámu trouby a poté troubu zavěsit. Podrobné informace naleznete v diagramu. Podrobné informace naleznete v návodu dodaném se saunovým ohřívačem.

Vodiče světla by měly být připojeny ke kabelové základně saunového topidla a napájeny přes saunové topidlo.

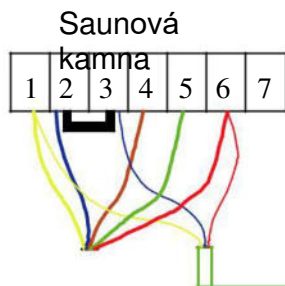
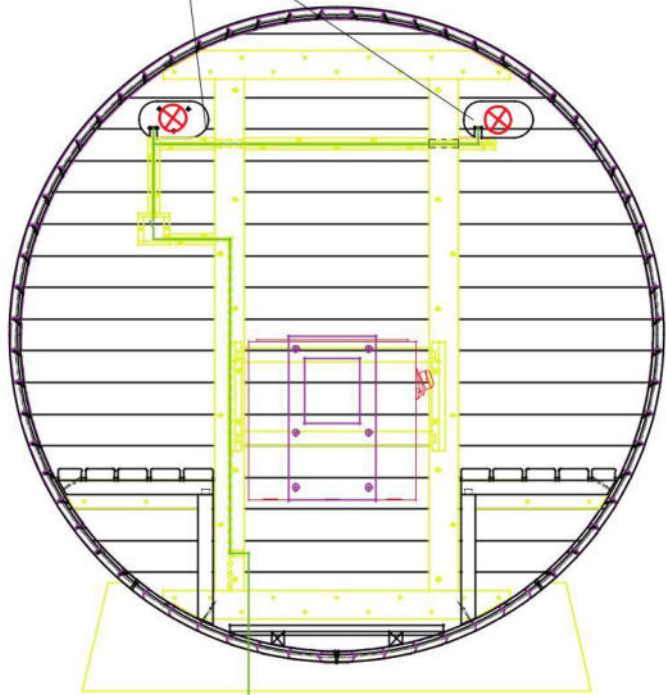
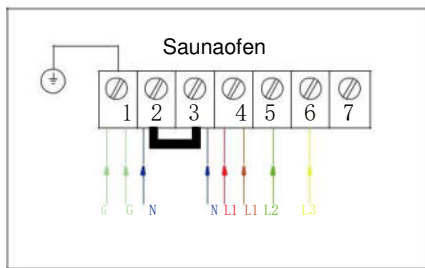
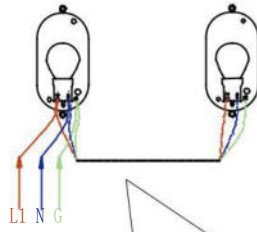

Napětí lampy (3*0,75mm²)

Kabel (5*2,5mm²)

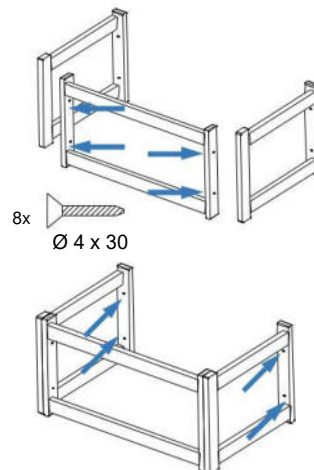
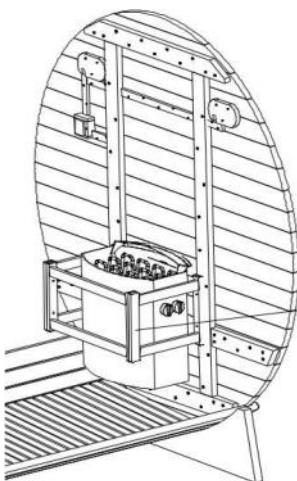

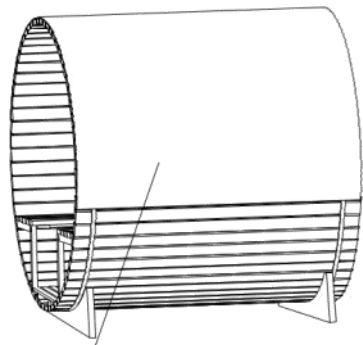

Voděodolná tkanina

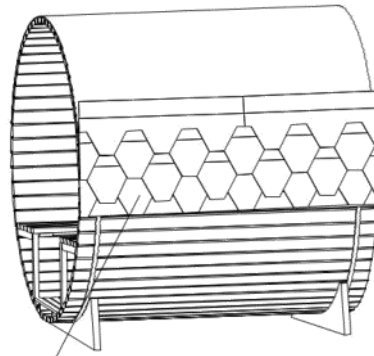

Šindel

Ø 4 x 12 200PCS

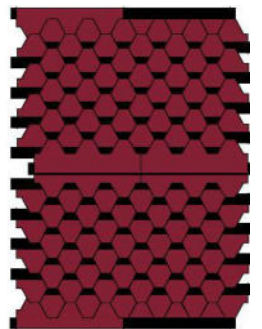
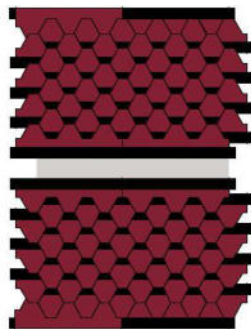
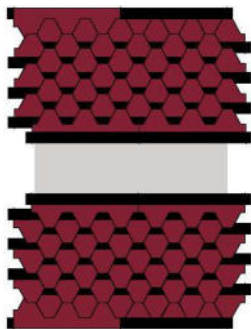
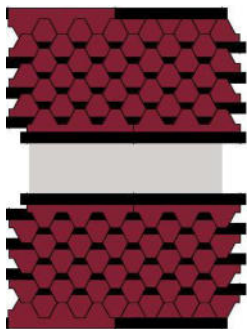
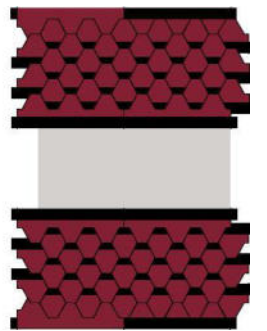
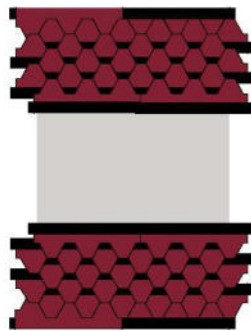
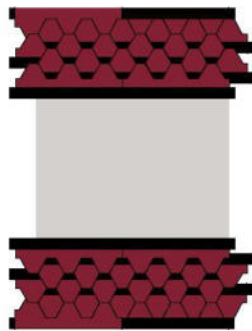
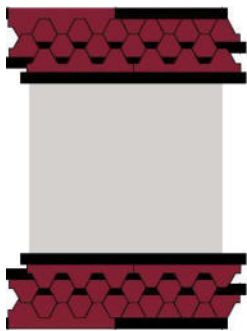
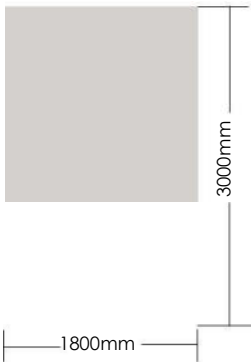

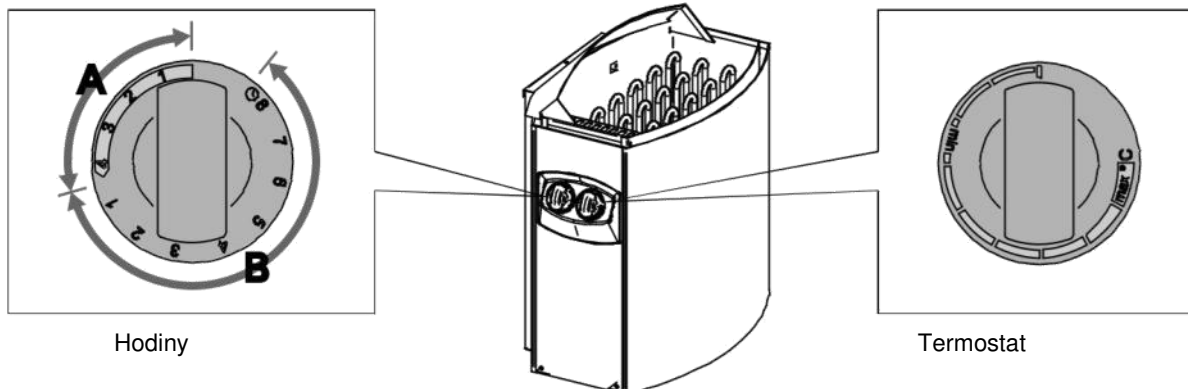

Hodiny

Termostat

1. Ohřivač zapnutí

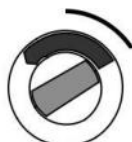

Přepněte tlačítko na "on".
(Část A na obr. 2, 0-4 hodiny).
Ohřivač začne okamžitě topit.

2. Přednastavený čas (časově řízené zapnutí)



Nastavte spínač časovače do sekce „Přednastavení“ (část B na obr.2, 0-8 hodiny). Ohřivač začne topit, když časovač přepne spínač zpět do polohy "on". Ohřivač pak bude zapnutý asi čtyři hodiny.

Podrobné informace o konkrétním použití a preventivních opatřeních saunového topidla naleznete v návodu k obsluze dodaném se saunovým topidlem.

Údržba

Ochrana dřeva

Kartáčujte každou vnější lištu sudu a po kompletní montáži naneste ochranný prostředek na ochranu dřeva.

Ochranný prostředek musel být obnoven podle doporučení použitého přípravku

DŮLEŽITÉ!

Před prováděním jakékoli práce odpojte napájecí kabel kabiny.

Zjištěné problémy	Možná příčina	Řešení
Kamna se nezahřívají.	Napájecí kabel není připojen	Zkontrolujte připojení napájecího kabelu.
	Obecné napájení je přerušeno.	Zkontrolujte zda zásuvka a elektrický panel fungují.
	Kamna jsou chráněna proti přehřátí	Viz. Návod ke kamnům..
Saunové světlo již není k dispozici	Světelný kabel není zcela připojen	Připojte kabel.
	Světlo je rozbité.	Obráťte se na svého prodejce.

Služby

1. Vypněte saunu.
2. Prach z prasklin v dřevěném obložení odstraňte vysavačem.
3. Vyčistěte kabinu vlhkým bavlněným hadříkem, v případě potřeby použijte malé množství mýdla. Opláchněte vlhkým hadříkem.
4. Očistěte sklo čisticím prostředkem na okna/skla a měkkým hadříkem.
5. Péče o vnější část sauny každé 2 roky vhodným přípravkem.

DŮLEŽITÉ!

Dřevo by mělo být ošetřeno ochranným prostředkem pouze na vnější straně sauny.

V sauně se nesmí provádět žádná léčba.

Na saunu nepoužívejte benzen, alkohol, chemikálie nebo silné čisticí prostředky, protože chemické přípravky mohou poškodit dřevo. Nestříkejte saunu vodou.

Přečtěte si prosím pokyny dodané se saunovým ohřívacem pro instalaci a používání ohříváče.

Ohříváč smí připojit k elektrické síti pouze oprávněný elektrikář v souladu s platnými předpisy.

**BC45, BC60, BC80, BC90
BC45E, BC60E, BC80E, BC90E**

Návod k použití



Tento návod k instalaci a obsluze je určen
obraťte se na majitele sauny nebo na majitele sauny
péči o odpovědnou osobu sauny, jakož i do
osoba odpovědná za instalaci saunového topidla
elektrikář. Když je saunové topidlo namontováno,
tento návod k instalaci a obsluze je zaslán na adresu
Majitelé sauny nebo osoby odpovědné za údržbu sauny
předat odpovědné osobě. Čti nahlas
vedení trouby do provozu podle návodu k obsluze
opatrně.

Kamna slouží k vytápění saunových kabin
při teplotě sauny. Využití pro ostatní
účely je zakázáno.
Gratulujeme vám k dobré volbě

Záruka:

- Záruční doba pro rodinné sauny
používaná saunová kamna a ovládací zařízení
je dva (2) roky.
- Záruční doba na saunová kamna a
Ovládací zařízení instalovaná ve veřejných saunách v
používaný v soukromých budovách je jeden
(1 rok.
- Záruka se nevztahuje na vady, které
v důsledku nesprávné instalace a použití
nebo nedodržení pokynů pro údržbu
vznikly.
- Záruka se nevztahuje na poškození
ty způsobené jiným použitím než z výroby
doporučené kameny saunových kamen

Návod k použití

1.1. Skládání kamenů saunových kamen

Vrstvení cihel pece má zásadní vliv na účinnost pece (obr. 1).

Důležité informace o kamenech saunových kamen:

- Kameny by měly mít průměr

mají 5-10 cm.

- Používejte pouze špičaté saunové kameny s drsným povrchem, které jsou určeny pro použití v saunových kamnech. Vhodné horninové typy jsou peridotit, olivinický dolerit a olivín.

- V sauně by topidlo nemělo být lehce porézní

Lze použít "kameny" vyrobené z keramiky nebo měkkého masťku. Absorbují, když

Nedostatek tepla, což má za následek a poškození topných těles.

- Kameny by měly být před stohováním

Kamenný prach, který má být osvobozen.

Při pokládání kamenů mějte na paměti následující:

- Nenechávejte kameny jen tak v troubě podzim.

- Vyhněte se zaklínění kamenů mezi topnými články.

- Kameny naskládejte volně, takto že mezi nimi může proudit vzduch.

- Naskládejte kameny tak, aby netlačte je na topná tělesa.

- Naskládejte kameny na sporák ne na vysoké hromadě.

- V Kamenné komoře nebo poblíž do saunového ohřivače by neměly být umístěny žádné předměty nebo zařízení jsou umístěny, že množství nebo Směr toho, který vede skrz saunová kamna změnit proudění vzduchu

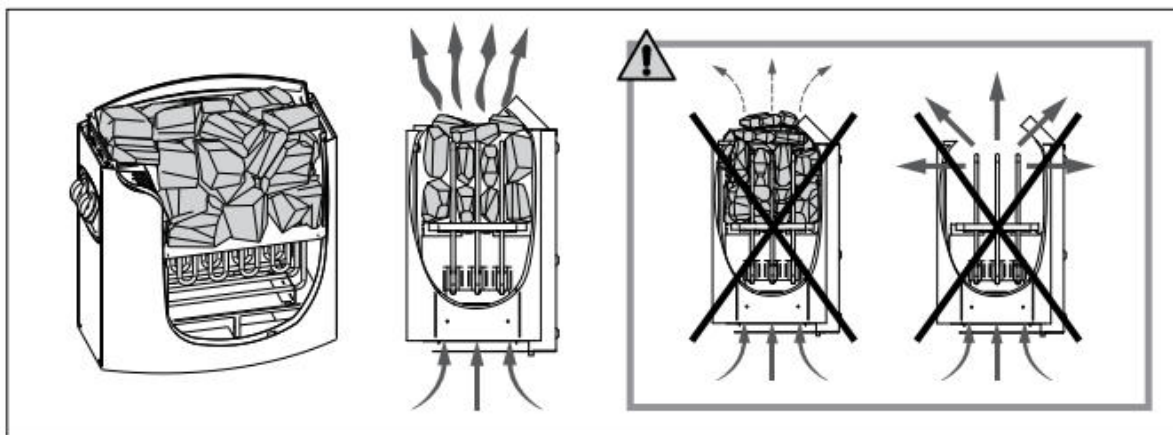

1.1.1. údržba

Vzhledem k velkým tepelným změnám, Saunové kameny křehké a křehké. Kameny by měly je třeba doplňovat alespoň jednou ročně, při pravidelném používání častěji. Při tomto Pokud máte možnost, odstraňte také prach a úlomky kamení ze spodní části saunového topidla a vyměňte poškozené kameny. V důsledku toho zůstává optimální topný výkon pece a riziko je zabráněno přehřátí.

1.2. Vytápění saunové kabiny

Odděluje se od saunového topidla při prvním zahřátí a voní kameny. K odstranění těchto saunová kabina musí být důkladně větrána. S kapacitou ohříváče vhodnou pro saunu je izolovaná sauna v dosahu hodinu na požadovanou teplotu sauny (2.3.). Kameny saunových topidel se na teplotu nálevu zahřívají zpravidla současně se saunovou kabinou. Správná teplota v saunové kabině se pohybuje kolem 65 až 80 °C.

1.3. používání trouby

Před zapnutím trouby zkontrolujte, zda na troubě nebo v ní nejsou žádné předměty v bezprostřední blízkosti pece. 1.6.

- Modely trouby BC45, BC60, BC80 a BC90 se dodává s časovačem a Vybaveno termostatem. Časovač reguluje dobu zapnutí trouby a to termostat teplotu. 1.3.1.–1.3.4.
- Modely trouby BC45E, BC60E, BC80E a BC90E se dodávají se samostatným ovládaná řídicí jednotka. věnujte pozornost dodaný návod k použití řízení

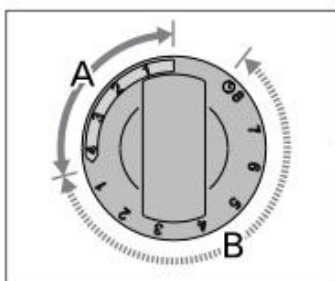

Figure 2. Timer switch
Abbildung 2. Schalter der Zeitschaltuhr

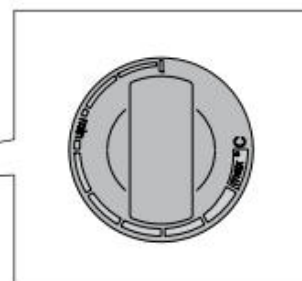
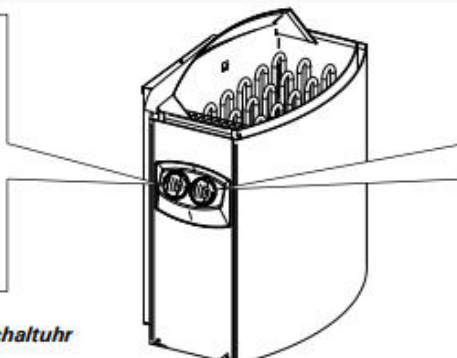

Figure 3. Thermostat switch
Abbildung 3. Thermostatschalter

1.3.1. zapnutá trouba



Nastavte časový spínač do oddílu "a" (oddíl A v Obr. 2, 0-4 hodiny). Trouba se spustí okamžitě zahřát.

1.3.2. Přednastavený čas (časově řízené zapnutí)



Nastavte časový spínač do sekce „Prefix“ (část B v obr. 2, 0-8 hodin). Trouba se spustí zahřívát, když je časovač otočil spínač zpět do zapnuté části. Poté trouba zůstane zapnutá asi čtyři hodiny

Příklad: Chcete jít tři hodiny procházet se a poté si dejte saunu. Místo spínač časovače do sekce "Prefix" na čísle 2.

Časovač začne běžet. Po dvou hodinách se trouba začne zahřívát. Vzhledem k tomu, že zahřátí sauny trvá asi hodinu, po asi budete připraveni na saunovou lázeň po dobu tří hodin, takže až se vrátíte z procházky.

1.3.3. trouba vypnutá



Trouba se vypne, když časovač přepnutí zpět na nulu otočil. Troubu můžete kdykoli sami vypnout stisknutím tlačítka Nastavte časovač na nulu. Po saunování vypněte topení. Někdy je vhodné troubu na chvíli nechat utíkej dál do dřevěných částí sauny pořádně uschnout. **POZORNOST!** Vždy se ujistěte, že Trouba je vypnutá a již nehřeje časovač přepnul spínač zpět na nulu

1.3.4. Nastavení teploty

Účelem termostatu (obr. 3) je udržovat teplotu v sauně na požadované úrovni zachovat. Experimentováním můžete určit jaké nastavení vám nejlépe vyhovuje.

Začněte s nejvyšším nastavením. -li teplota během saunování je příliš vysoká zvyšuje, otočte přepínačem mírně proti směru hodinových ručiček ve směru hodinových ručiček. Všimněte si, že nahoře Teplotní rozsah také malé změny výrazně ovlivňují teplotu v sauně.

1.4.

Vzduch v sauně se proto při zahřátí vysušuje voda by měla být aplikována na horké kameny saunového topidla, aby se dosáhlo příjemné úrovně vlhkosti být obsazen. Účinky tepla a Páry se liší od člověka k člověku - metodou pokusů a omylů najdete úroveň teploty a vlhkosti, které vám nejlépe vyhovují jsou vhodné.

POZORNOST! Kapacita saunové naběračky by měla ne více než 0,2 l. Na kameny by se nemělo lít velké množství vody najednou jinak vroucí při odpařování voda by mohla stříkat na koupající se. Dávej si pozor Dávejte si také pozor, abyste kameny nelili vodou, když je někdo v jejich blízkosti. z horká pára by mohla způsobit popáleniny. **POZORNOST!** Jako infuzní voda by měla být použita pouze voda používat, které splňují požadavky na kvalitu Voda pro domácnost splněna (tabulka 1). V nálevové vodě lze použít pouze vonné látky k tomu určené. Postupujte podle pokynů na obalu.

Water property Wassereigenschaft	Effect Wirkung	Recommendation Empfehlung
Humus concentration Humusgehalt	Colour, taste, precipitates Farbe, Geschmack, Ablagerungen	< 12 mg/l
Iron concentration Eisengehalt	Colour, odour, taste, precipitates Farbe, Geruch, Geschmack, Ablagerungen	< 0,2 mg/l
Hardness: most important substances are manganese (Mn) and lime, i.e. calcium (Ca). Wasserhärte: Die wichtigsten Stoffe sind Mangan (Mn) und Kalk, d.h. Kalzium (Ca).	Precipitates Ablagerungen	Mn: < 0,05 mg/l Ca: < 100 mg/l
Chlorinated water Gechlortes Wasser	Health risk Gesundheitsschädlich	Forbidden to use Darf nicht verwendet werden
Seawater Salzwasser	Rapid corrosion Rasche Korrosion	Forbidden to use Darf nicht verwendet werden

1.5. Pokyny pro sauny

- Před saunováním se umyjte.
- Zůstaňte v sauně tak dlouho, jak o tom budete uvažovat cítit se pohodlně.
- Zapomeňte na veškerý stres a relaxujte.
- Dobré saunování zahrnuje ohleduplnost k ostatním koupajícím se
Nechovejte se zbytečně hlučně
rušit.
- Nevyhánějte s sebou ani ostatní mnoho infuzí.
- Mezitím nechte nahřátou pokožku vychladnout. Pokud jste zdraví a můžete, jděte plavat.
- Po saunování se umyjte.
- Odpočívejte, dokud nebudete v rovnováze cítit. Pijte čistou vodu nebo a
Nealkoholický nápoj pro zvýšení rovnováhy tekutin stabilizovat

1.6. varování

- Dlouhý pobyt v horké sauně vede ke zvýšení tělesné teploty, co může být nebezpečné.
- Pozor na horkou saunovou pec. Kameny a kryt se velmi zahřeje a může popálit kůži.
- Udržujte děti mimo dosah trouby.
- Děti, handicapovaní, nemocní a slabí nesmí zůstat v sauně sám.
- Zdravotní omezení související s saunou je nutné konzultovat s lékařem vůle.
- O saunách malých dětí byste měli vyhledejte radu v mateřské poradně.
- Nechodte do sauny, pokud jste pod vodou vliv omamných látek (alkohol, léky, drogy atd.).
- Nikdy nespěte ve vyhřáté sauně.
- Mořské a vlhké podnebí může zrezivět kovové povrchy saunového topidla.
- Nepoužívejte saunu k sušení oblečení nebo prádla kvůli nebezpečí požáru. kromě toho mohou být elektrické spotřebiče vysoká vlhkost může být poškozena.

1.7. poruchy

Nebezpečí! Veškerá údržba musí být provedena do kvalifikovaný technický personál vůle.

Trouba se nezahřívá.

- Zkontrolujte pojistky

trouby jsou v dobrém stavu.

- Zkontrolujte, zda je propojovací kabel zapojeno (3.3.).

- Nastavte časovač na část „on“ (1.3.1.).

- Nastavte termostat na vyšší hodnotu Nastavení (1.3.4.).

- Zkontrolujte, zda je ochrana proti přehřátí byl spuštěn. Časovač běží, ale kamna se nezahřívají. (3.5.

- Zkontrolujte pojistky

trouby jsou v dobrém stavu.

- Ujistěte se, že při

když je trouba zapnutá, všechna topná tělesa svítí.

- Nastavte termostat na vyšší hodnotu Nastavení (1.3.4.).

- Zkontrolujte, zda je výkon pece je dostačující (2.3.).

- Zkontrolujte kameny saunových kamen (1.1.).

Příliš těsná hromada kamenů, že

Usazování kamenů v průběhu času a nesprávné

Typy kamenů mohou omezit proudění vzduchu skrz

Trouba překáží, což má za následek snížení

topné napájecí kabely.

- Ujistěte se, že je zajištěno větrání

Saunová kabina je správně nastavena (2.2.).

Saunová kabina se rychle zahřeje, ale

Teplota kamenů je nedostatečná. že nahoru

protéká kamenná voda.

- Nastavte termostat na nižší hodnotu Nastavení (1.3.4.).

- Zkontrolujte, zda výkon trouby není příliš vysoký je vysoká (2.3.).

- Ujistěte se, že je zajištěno větrání

Saunová kabina je správně nastavena (2.2.).

Saunová kabina se zahřívá nerovnoměrně.

- Ujistěte se, že je trouba v správnou výšku. Trouba saunu umí vyhřát nejlépe, když on 100 mm nad podlahou. a maximální montážní výška je 200 mm. (3.2.)

Panely a další materiály vedle kamen rychle zčerná.

- Ověřte požadavky na jsou dodržovány bezpečnostní vzdálenosti (3.1.).
- Zkontrolujte kameny saunových kamen (1.1.). Příliš těsná hromada kamenů, že Usazování kamenů v průběhu času a nesprávné Typy kamenů mohou omezit proudění vzduchu skrz Ucpání trouby, což má za následek přehřátí trouby okolní materiály.
- Viz také část 2.1.1.

Trouba vydává pachy.

- Viz část 1.2.
- Horká trouba může vytvářet zápach ve vzduchu zvýšit, ale ne přes saunu nebo samotná pec. Příklady: barva, lepidlo, olej, koření.

Trouba vydává hluk.

- BC: Časovač je mechanický zařízení, a proto způsobuje tikání hluk při běžné práci. Tikání zní, i když kamna nejsou je zapnuto, prozkoumejte Připojení časovače.
- Někdy se objeví náhlé praskání praskáním kamenů vlivem tepla.
- Roztahování částí trouby vlivem tepla může vydávat hluk, když se trouba zahřívá způsobit

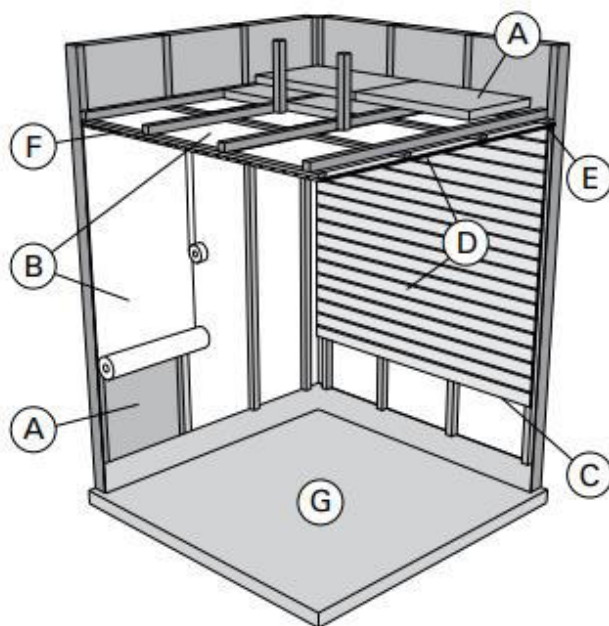

ure 4.
bildung 4.

A. Izolační vlna, tloušťka 50-100 mm. Saunová kabina musí být pečlivě izolována, aby se trouba nemusí produkovat příliš velký výkon.

B. Ochrana proti vlhkosti, např. hliníkový papír. a lesklá strana papíru musí jít do sauny prokázat. Utěsněte švy hliníkovou páskou.

C. Přibližně 10 mm mezera mezi ochranou proti vlhkosti a obložením (doporučení).

D. Lehká panelová deska o tloušťce 12-16 mm. před začátek obložení elektroinstalace a zkontrolujte výztuhy ve stěnách potřebné pro kamna a lavice.

E. Přibližně 3 mm mezera mezi obložením stěny a stropu.

Otázka: Nadmořská výška sauny je obvykle 2100–

2300 mm. Minimální výška závisí na sporáku

(viz tabulka 2). Vzdálenost mezi

horní lavice a strop by měly být max

být 1200 mm.

G. Keramické a tmavé podlahové krytiny

Použijte cementovou kaši. Částice unikající ze saunových kamenů a nečistoty ve vodě mohou

poškodit citlivé podlahy

odbarvit nebo poškodit.

POZOR! Zeptejte se úřadů, která část žáruvzdornou stěnu lze izolovat. Kouřovody, které se používají, nesmí být izolovány.
POZORNOST! Lehké ochranné kryty připevněné přímo na stěnu nebo strop představují nebezpečí požáru.

2.1.1. Černění stěn sauny

Je zcela normální, pokud jsou dřevěné povrchy časem v sauně změny barvu. Černění je zrychlen tím

- Sluneční světlo
- Teplota trouby
- Ochrana obložení na stěnách (s malou odolností vůči teplotě)
- Jemné částice uvolňované do vzduchu z rozpadajících se saunových kamenů.

2.2. Větrání saunové kabiny

Vzduch v sauně by se měl měnit šestkrát za hodinu. Obr. 5 ukazuje různé možnosti ventilace sauny.

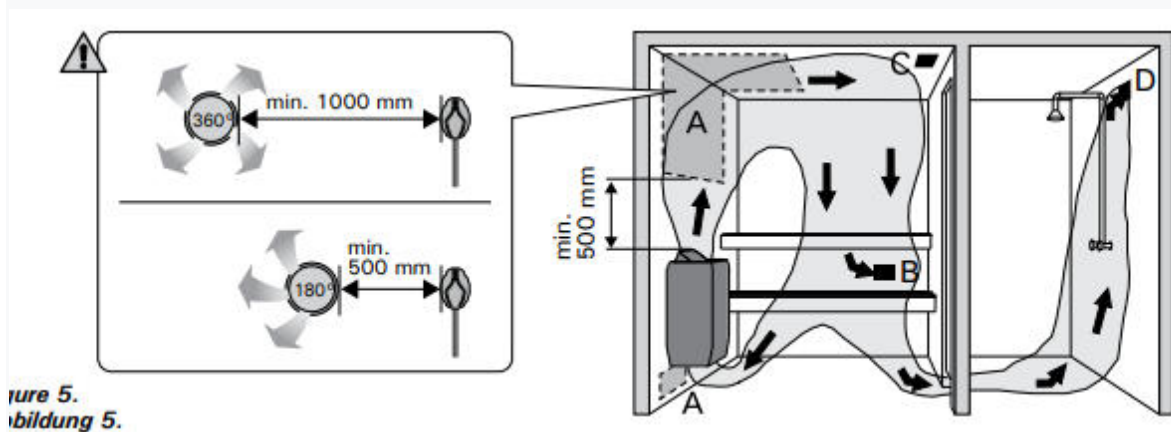

Figure 5.
 Abbildung 5.

A. Přívod vzduchu. V případě mechanického odvětrání umístěte nad kamna přívod vzduchu. V případě gravitačního větrání přívod vzduchu pod nebo vedle připevněte k troubě. Průměr potrubí přívodu vzduchu musí být 50-100 mm.

BC-E: Neumisťujte přívod vzduchu tak, aby byl teplotní senzor se ochladí (pro připojení teplotního čidla, viz návod k instalaci řídicí jednotky)!

B. Vent. instalovat ventilaci v blízkosti podlahy, co nejdále od trouby. Průměr odvětrávací trubky by měl být dvojnásobný být velký jako u přívodu vzduchu.

C. Volitelné větrání pro sušení (během topení a koupelna uzavřena). Sauna může lze sušit i otevřenými dvířky.

D. Pokud je ventilační otvor v umývárně, mezera pod dveřmi sauny musí být min být 100 mm. Mechanické odvětrání je povinnost.

2.3. výkon pece

Pokud jsou stěna a strop obložené a dostatečné jsou izolované, výstupní výkon závisí na

topidlo podle objemu sauny. Není izolovaný

Stěny (kámen, skleněné tvárnice, sklo, beton, dlaždice)

zvýšit požadovaný výkon pece. Každý metr čtvereční neizolované stěny odpovídá 1,2 m³ navíc objemu sauny. Saunová kabina 10 m³ s

Například skleněné dveře odpovídají výkonu

12 m³ sauna. U dřevěných stěn vynásobte objem sauny 1,5. Vyberte správný výkon pece z tabulky 2.

2.4. Hygiena saunové kabiny

Aby se lavičky nepotily, používejte plážové osušky chránit.

Lavice, stěny a podlaha sauny minimálně

umýt každých šest měsíců. Použijte kartáč a čisticí prostředek na saunu.

Prach a nečistoty z trouby otřete vlhkým hadříkem

setřít. Usazeniny vodního kamene na sporáku s 10 %

Odstraňte kyselinu citronovou a opláchněte.

3.1. Před montáží

Před instalací saunového topidla si přečtěte

montážní návod a zkontrolujte následující věci:

- Je saunové topidlo, které má být instalováno, v provozu?

a typ vhodný do saunové kabiny? a

Hodnoty objemu v tabulce 2 nesmí ani jedno

má být podříznuto.

- Je síťové napětí vhodné pro saunová kamna?

- Místo instalace kamen splňuje minimální bezpečnostní vzdálenosti uvedené na obrázku 6 a tabulce 2.

Tyto vzdálenosti musí být přísně dodržovány

protože odchylka vytváří nebezpečí požáru.

V sauně smí být instalováno pouze jedno saunové topidlo

vůle

Heater Ofen	Out- put Leis- tung	Sauna room Saunakabine		Electrical connections Elektroanschlüsse					
		Cubic vol. Rauminhalt	Height Höhe	400 V 3N~ Connecting cable Anschlusskabel		Fuse Sicherung	230 V 1N~ Connecting cable Anschlusskabel		Fuse Sicherung
Width/Breite • BC 480 mm • BC-E 450 mm Depth/Tiefe 310 mm Height/Höhe 540 mm Weight/Gewicht 11 kg Stones/Steine max. 20 kg		> 2.3.		See fig. 8. The measurements apply to the connecting cable only! Siehe Abbildung 8. Die Messungen beziehen sich ausschließlich auf das Anschlusskabel!					
	kW	min. m ³	max. m ³	min. mm	mm ²	A	mm ²	A	mm ²
BC45/BC45E	4,5	3	6	1900	5 x 1,5	3 x 10	3 x 2,5	1 x 20	4 x 0,25
BC60/BC60E	6,0	5	8	1900	5 x 1,5	3 x 10	3 x 2,5	1 x 35	4 x 0,25
BC80/BC80E	8,0	7	12	1900	5 x 2,5	3 x 16	3 x 6	1 x 35	4 x 0,25
BC90/BC90E	9,0	8	14	1900	5 x 2,5	3 x 16	3 x 10	1 x 50	4 x 0,25

Table 2. Installation details

Tabelle 2. Montageinformationen

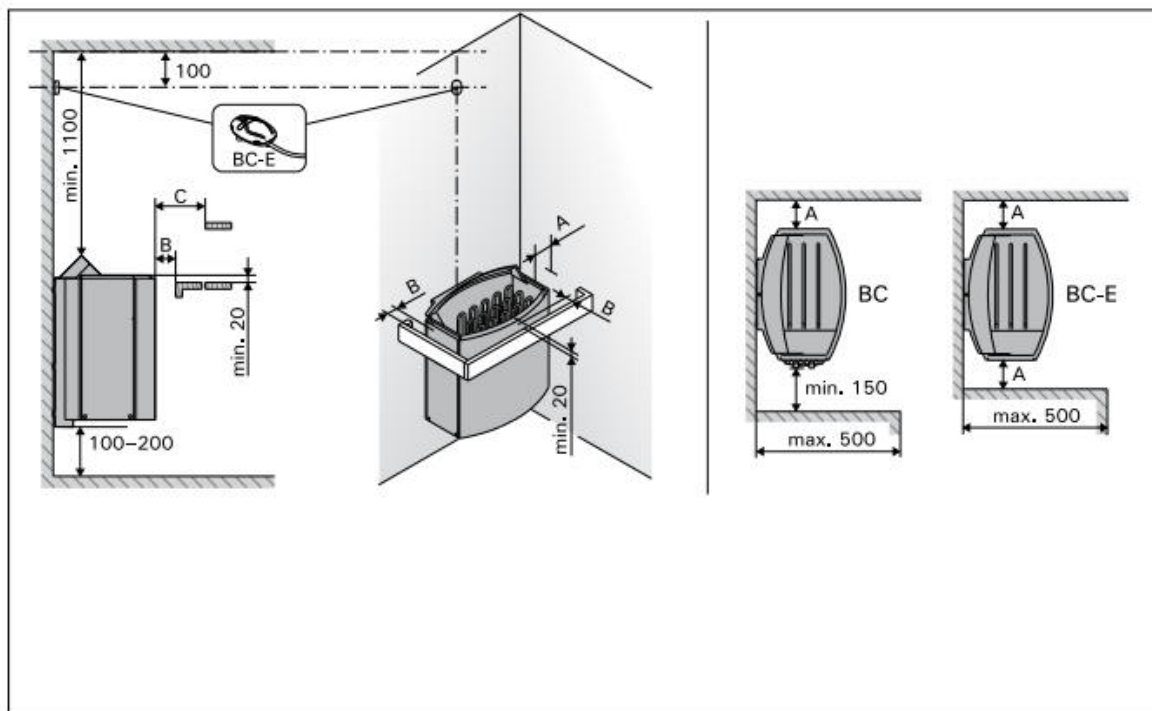

Figure 6. Safety distances (all dimensions in millimeters)

Abbildung 6. Sicherheitsmindestabstände (alle Abmessungen in Millimetern)

3.2. Upevnění saunového topidla na stěnu

Viz obrázek 7.

1. Před montáží odstraňte oba ochranné kartony!

2. Upevněte montážní rám pomocí
dodávané šrouby na stěnu.

POZORNOST! V místech, kde se
jsou připevněny upevňovací šrouby
musí být za panely jako podpěra, např.
umístěnou desku, ve které jsou šrouby pevně utaženy
sedět. Pokud za panely nejsou žádné
Desky jsou umístěny, mohou být i v přední části
panely jsou připojeny.

3. Saunová kamna lze ovládat skrz

Pravák nebo levák jinak na

být namontován na stěnu. Ujistěte se, že Správně zajištěné upevňovací průchodky zavěšení sedět.

4. Zvedněte saunové topidlo na rám stěny, za kterou se upevňovací háčky ve spodní části zaháknou. Stojan za okraj tělesa saunového topidla. Přijít. Odšroubujte horní část saunové topidlo k montážnímu rámu.

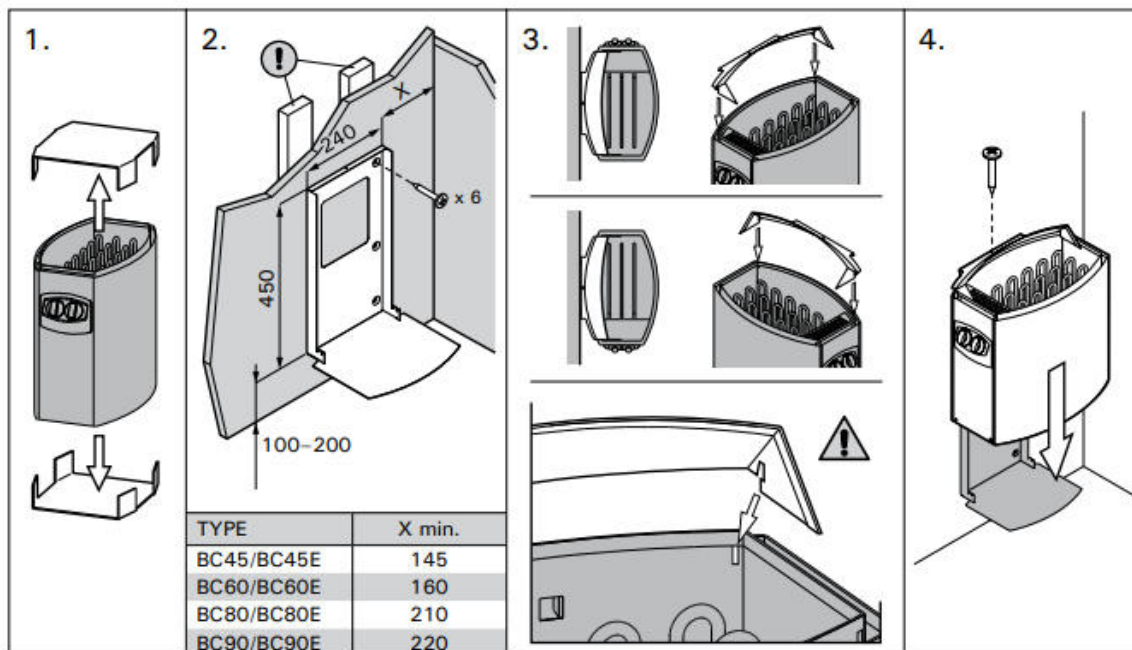

Figure 7. Fastening the heater on a wall (all dimensions in millimeters)
Abbildung 7. Befestigung des Saunaofens an der Wand (alle Abmessungen in Millimetern)

3.3. elektrické spoje

Připojení saunového topidla k napájení je povoleno smí provádět pouze autorizovaný elektrikář v souladu s platnými předpisy.

- Saunové topidlo je polotěsně připojeno ke svorkovnici (obr. 8: A) připevněný ke stěně sauny. a Spojovací skříňka musí být odolná proti stříkající vodě a smí umístěn nejvýše 500 mm nad podlahou.
- Jako propojovací kabel se používá pryžový kabel typu H07RN-F nebo odpovídající kabel (obr. 8: B). **POZORNOST!** Kabely izolované PVC nejsou povoleny kvůli jejich špatné kvalitě Tepelná odolnost není jako připojovací kabel lze použít saunový ohřivač.
- Pokud je konektor nebo montážní kabely výše než 1000 mm nad zemí proudění do sauny nebo stěn sauny, musí odolat teplotě minimálně 170 °C při zatížení (např. SSJ). Elektrická zařízení, která jsou výše než 1000 mm od podlahy sauny pro použití musí být připojen povoleno při okolní teplotě 125 °C (Poznámka T125).
- Saunová kamna BC jsou kromě síťového připojení vybavena svorkou (P), která nabízí možnost ovládání elektrického ohřevu (obr. 10). Trouba přebírá vedení

se zapnutím regulace napětí.
 Ovládací kabel pro elektrický ohřivač
 se stává spojovací krabicí saunového topidla
 položenou a odtud gumovým kabelem
 stejné tloušťky jako svorkovnice
 saunového topidla
 Buďte opatrní při zavírání víka
 rozvodné skříňky, že je kryt zavřený
 zcela uzavřeno. Pokud ne víko
 správně, voda může téct do připojovací skříňě. ilustrace

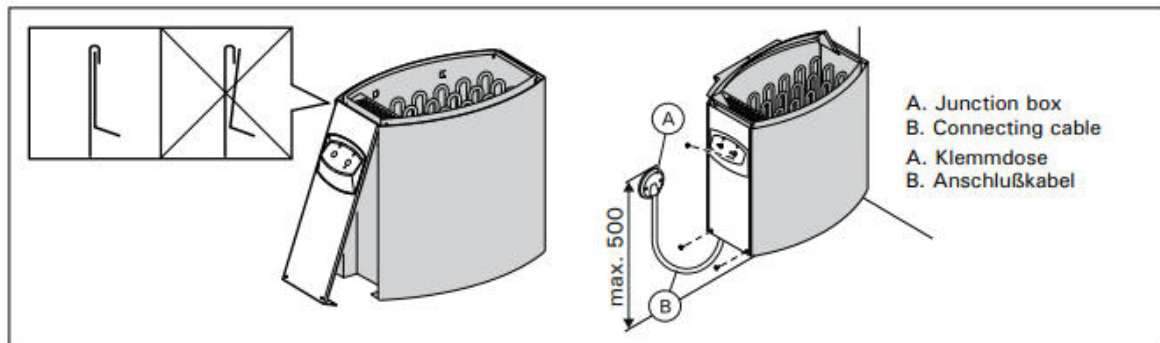

Figure 8. Closing the cover of the connection box (all dimensions in millimeters)
Abbildung 8. Das Verschließen des Anschlusskastens (alle Abmessungen in Millimetern)

3.3.1. Izolační odpor elektrického saunového topidla

Při výstupní revizi elektroinstalace
 při měření izolačního odporu
 Dochází k „úniku“, což je způsobeno tím
 Vlhkost ze vzduchu do izolačního materiálu
 došlo k výskytu topných odporů (během skladování
 a doprava). Vlhkost uniká z
 Odporů po dvou zahřátích.
 Vypněte elektrické napájení saunového topidla
 ne přes proudový chránič.

3.4. Zapojení řídicí jednotky a Senzor (BC-E)

Podrobný návod, jak upevnit řídicí jednotku na stěnu, je přiložen k řídicí jednotce
 daný. Teplotní čidlo je připevněno ke stěně sauny nad saunovým topným tělesem, 100 mm pod ním
 připevněna ke stropu na ose ve směru šířky saunové pece. Obrázek 6.
 Nepřipevňujte přívod vzduchu takovým způsobem, aby byl
 Teplotní senzor se ochladí. Obrázek 5

3.5. Resetujte ochranu proti přehřátí

Pokud je teplota v sauně nebezpečná
 prudce stoupá, ochrana proti přehřátí se přeruší
 napájení pece je trvalé. Ochrana proti přehřátí lze resetovat po vychladnutí kamen.

BC

Resetovací tlačítko se nachází v připojovací skříni trouby (obr. 9). pouze jeden Tyto práce mohou provádět osoby oprávněné k provádění elektroinstalací.

Před stisknutím tlačítka příčina poruchu lze zjistit:

- Jsou kameny v saunových kamnech zaklíněné nebo křehké?
- Bylo saunové topidlo delší dobu zapnuté a nebyl použit?
- Je čidlo termostatu špatně zapnuté místo nebo závada?
- Bylo saunové topidlo vystaveno silným nárazům?

BC-E

Viz návod k použití a montáž řídicí jednotka.

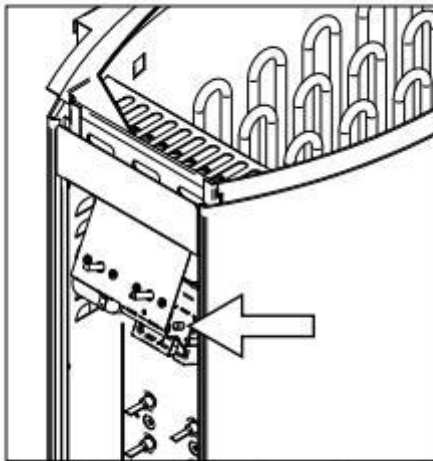

Figure 9. Reset button for overheat protector
Abbildung 9. Rücksetzknopf des Überhitzungsschutzes

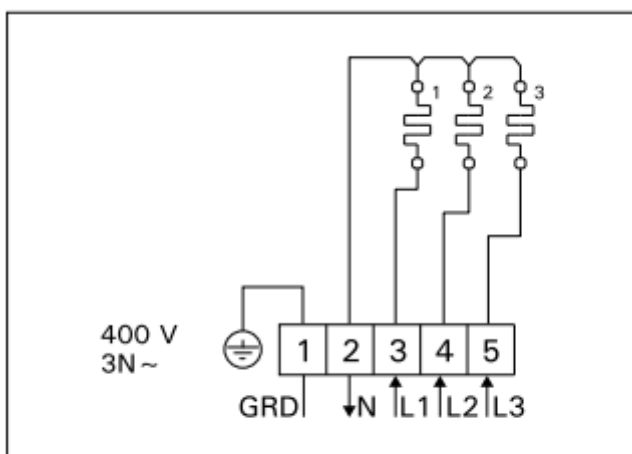

Figure 11. Electrical connections of BC-E heater
Abbildung 11. Elektroanschlüsse des Saunaofens BC-E

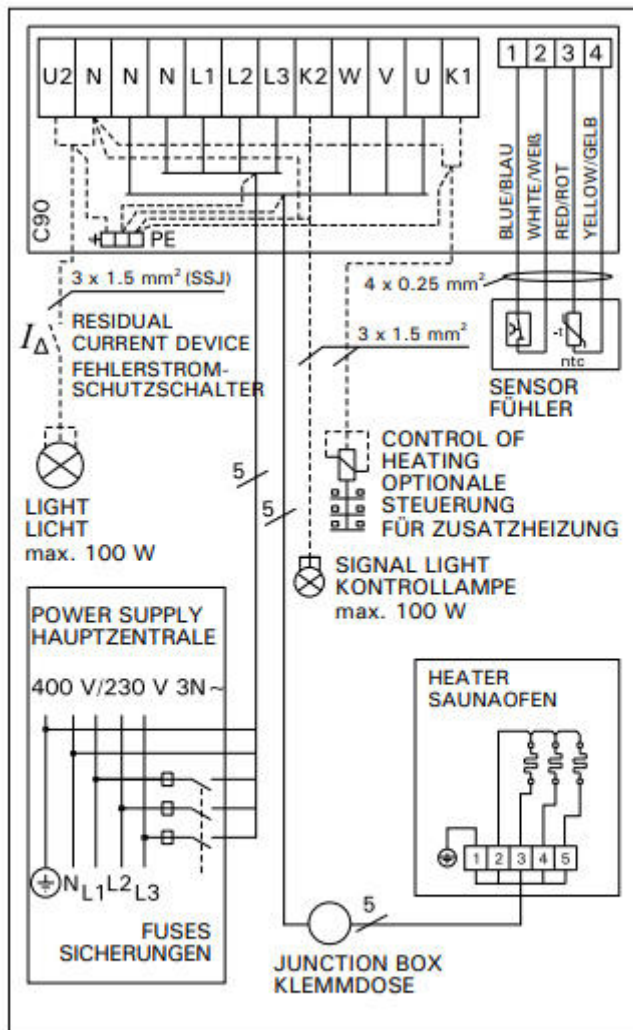

Figure 12b. 3-phase electrical connections of control unit C90 and BC-E heater

Abbildung 12b. 3-phasiger Elektroanschlüsse des Steuergerät C90 und des Saunaofens BC-E

E

Náhradní díly

1	ZSB-224	1500 W/230 V
2	ZSB-226	2000 W/230 V
3	ZSB-228	2670 W/230 V
4	ZSB-229	3000 W/230 V
5	ZSK-510	⌚ (BC)
6	ZSB-125	
7	ZSK-520	°C (BC)
8	ZSB-115	

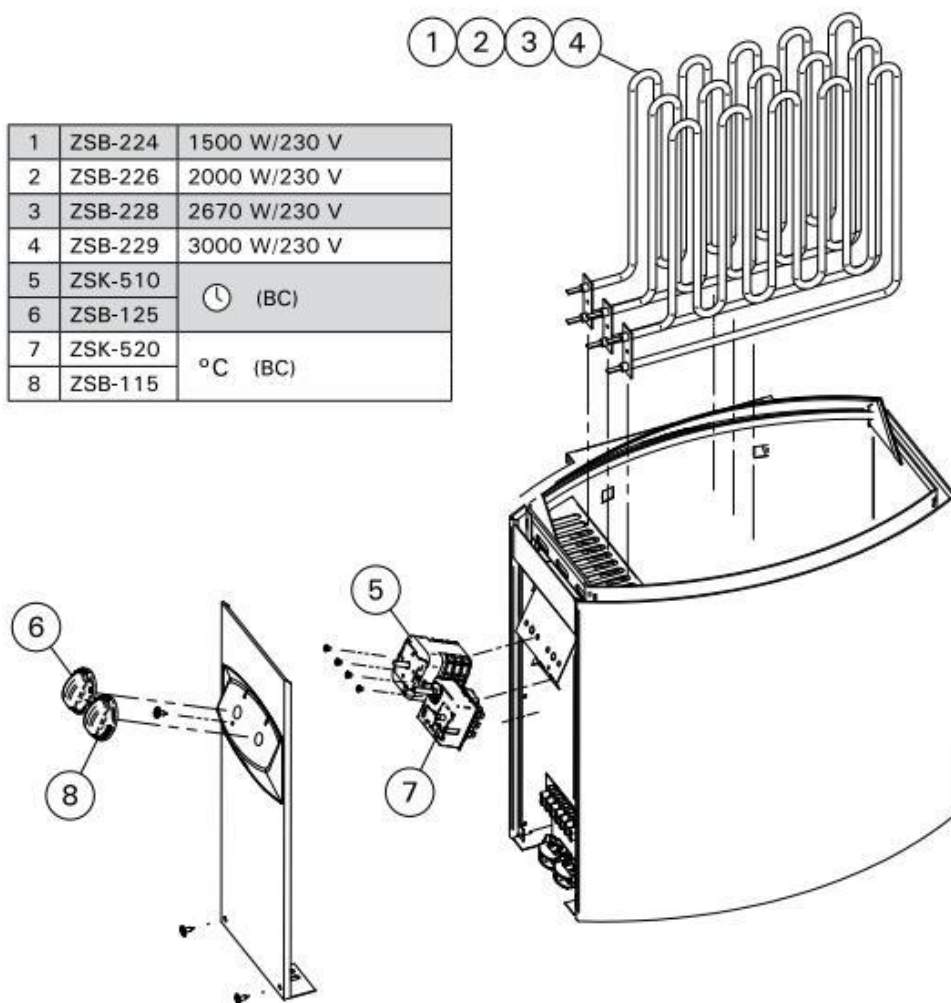

Navodilo za montažo

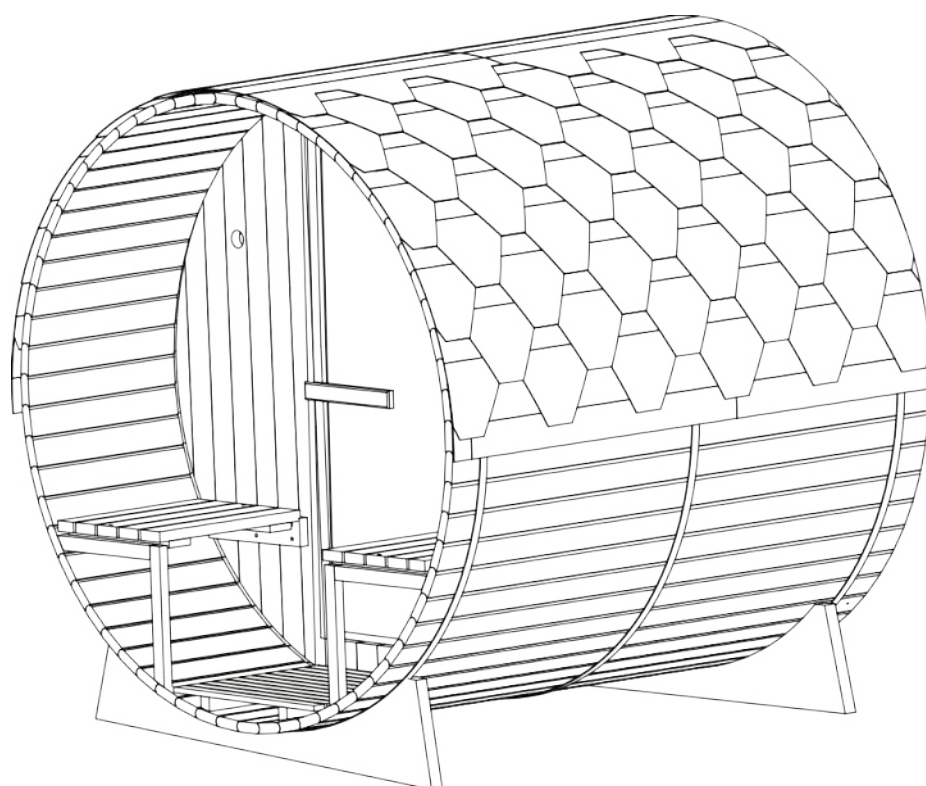

— Infrardeča svetloba omogoča bolj zdravo življenje —

Zaradi nenehnega izboljševanja izdelkov se lahko izdelek, prikazan v teh navodilih za uporabo, nekoliko razlikuje od dejanskega izdelka.

Priporočila

Pred prvo uporabo savne natančno preberite ta navodila.

Priporočamo, da jih hranite na varnem mestu, da vam bodo zmeraj dosegljiva.

- Les je živ element. Da bi ohranili njegov prvotni videz, je treba les na zunanji strani zaščititi pred vlago.
- Postavite savno na popolnoma ravno in trdo površino.
- Savno je treba postaviti v suh prostor. Ne uporabljajte je v bližini vira vode (kad, vlažna tla, bazen).
- Ne uporabljajte tekočih čistilnih sredstev. Pred čiščenjem izklopite savno in uporabite le vlažno krpo.
- Zaščitite električni kabel savne, da se ne zmečka ali stisne.
- Pred zamenjavo določenih sestavnih delov se prepričajte, da jih je določil proizvajalec ali da imajo enake lastnosti kot originalni deli. Nepravilna zamenjava lahko povzroči požar, kratek stik ali poškodbe savne. Priporočamo, da se posvetujete z usposobljenim tehnikom.
- Da bi se izognili nevarnosti opeklin ali električnega udara, ne uporabljajte kovinskih orodij.
- V savno ni dovoljeno prinašati živali.
- Savne ne puščajte vklopljene brez nadzora.
- Savne ne puščajte vklopljene več kot 3 ure naenkrat, da ne pride do prezgodnje poškodbe naprave. Po 3 urah neprekinjenega delovanja savno za vsaj eno uro izklopite.
- Priporočljivo je, da na vrata savne ne namestite sistema za zaklepanje.
- Pred priključitvijo savne na električno omrežje preverite, ali vaša električna napeljava izpolnjuje zahteve.

Varnostne informacije

POMEMBNO :

Pred postavitvijo in uporabo kabine za savno natančno preberite varnostna navodila. So bistvenega pomena za vašo varnost, zato jih natančno upoštevajte.

Pazite na hipertermijo, toplotno kap ali vročinsko izčrpanost, ki jih lahko povzročite ali poslabšate, če ne upoštevate varnostnih navodil. Simptomi so vročina, hiter utrip, omotica, omedlevica, letargija in odrevenelost celotnega telesa ali njegovih delov. Učinki so: zmanjšano zaznavanje toplote, ne zavedanje grozeče nevarnosti, nezavest.

Savne ne smejo uporabljati:

- otroci, mlajših od 6 let.
- ljudje s hudimi reakcijami na sončno svetlobo.
- starejše osebe ali invalidi.
- ljudje z že obstoječimi boleznimi, kot so bolezni srca, visok ali nizek krvni tlak, težave s krvnim obtokom ali sladkorna bolezen, brez predhodnega zdravniškega nasveta.
- nosečnice. Previsoka temperatura lahko ogrozi plod.
- osebe z dehidracijo, odprtimi ranami, očesnimi boleznimi, opeklinami ali sončnim udarcem.

Otroci, stari od 6 do 16 let, lahko uporabljajo savno, če so ves čas pod nadzorom odgovorne odrasle osebe in če temperatura v savni ne presega 60 °C.

Če imate zdravstvene težave, jemljete zdravila ali imate poškodovane mišice ali vezi, lahko savno uporabljate le po predhodnem posvetu in odobritvi zdravnika.

Če nosite kirurške vsadke, ne uporabljajte savne, ne da bi se prej posvetovali z zdravnikom in pridobili njegovo soglasje. Savne ne uporabljajte po naporni dejavnosti.

Počakajte 30 minut, da se vaše telo ohladi.

V savni ne preživite več kot 40 minut naenkrat

Pred ali med savnanjem ne uživajte alkohola ali drog.

V delujoči savni ne spite.

Da bi se izognili nevarnosti pregrevanja, savno priključite v dovolj močno vtičnico in v isto vtičnico ne priključite drugih električnih naprav.

Da bi se izognili nevarnosti električnega udara ali poškodbam savne, je ne smete uporabljati:

- med nevihto.
- če je električni kabel poškodovan, ga mora zamenjati usposobljena oseba.
- če se električni kabel pregreje, ga mora preveriti usposobljena oseba.
- če morate zamenjati žarnico, počakajte, da je savna izklopljena in se ohladi.

Preden priključite ali izključite napajanje, si posušite roke. Nikoli ne delajte z mokrimi rokami ali nogami.

Ne vklaplajte ali izklaplajte napajanja ali ogrevalnega sistema na hitro, saj lahko to povzroči škodbe električnega sistema.

Savne ne poskušajte popravljati sami, ne da bi za to pridobili soglasje prodajalca ali proizvajalca.

Nepooblaščen poskus popravila bodo povzročili izgubo proizvajalčeve garancije.

V savni ne uporabljajte nobenih čistilnih sredstev.







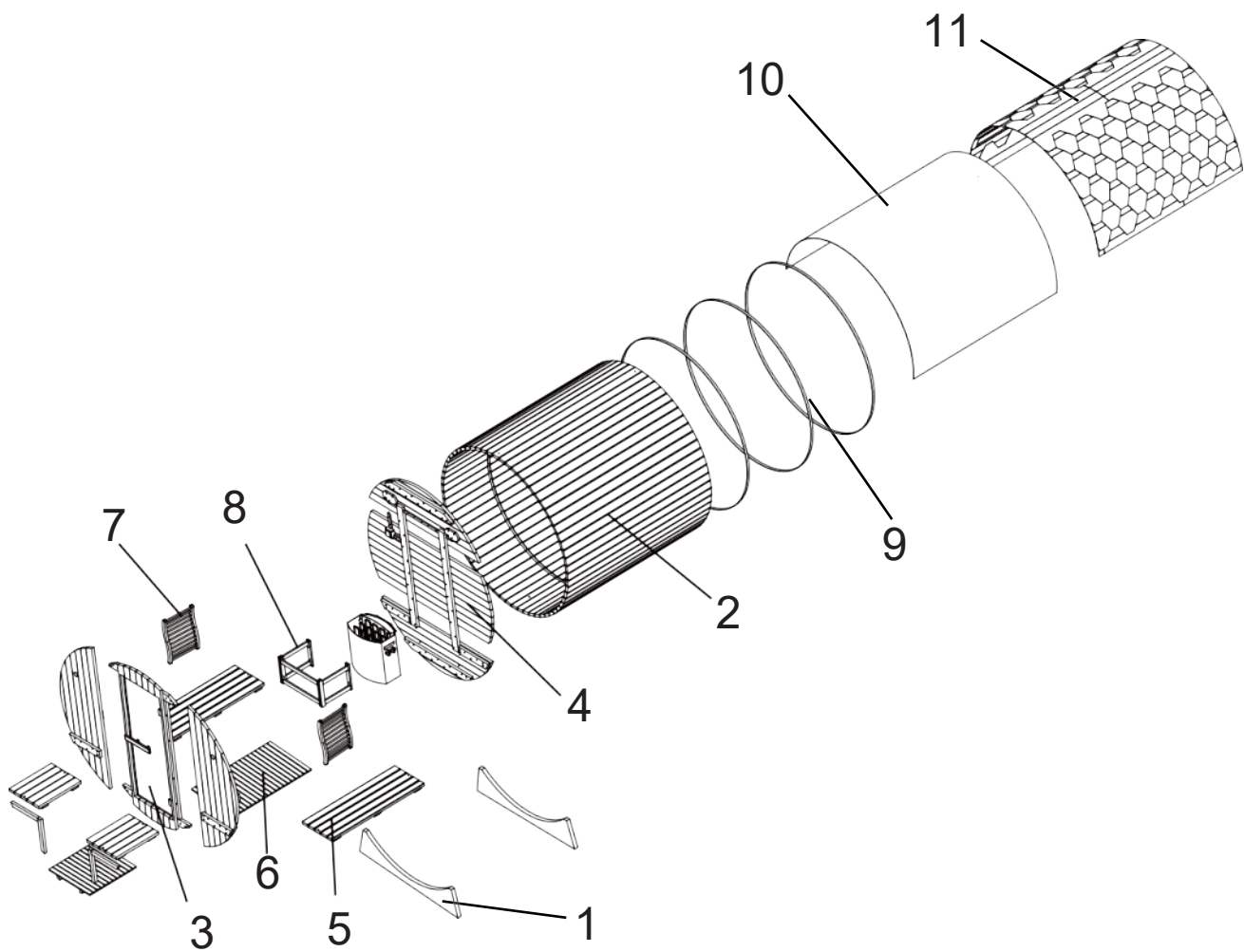

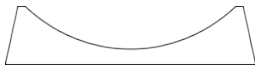

V savno ali na njo ne zlagajte ali shranjujte nobenih predmetov.

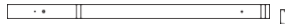
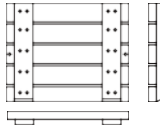
V bližini savne ne postavljajte vnetljivih materialov ali kemičnih snovi.

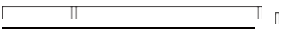
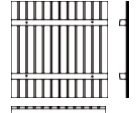

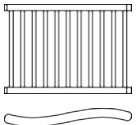
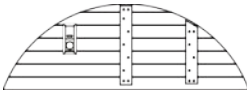
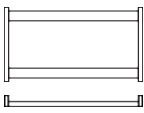
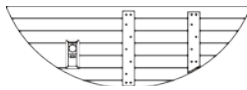
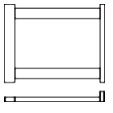
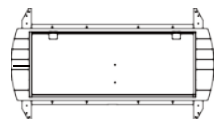

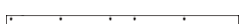

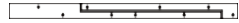
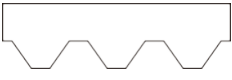
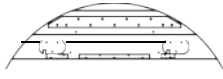
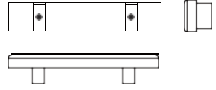
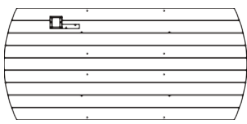
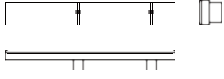
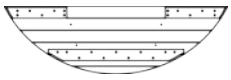
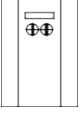
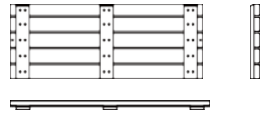
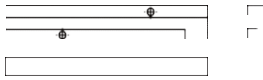
Opis savne





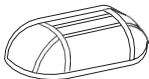
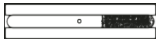

Opis savne

1		(1400x300x33mm) 2x	5.2		(426x398x30mm) 2x
2.1		(1800x93x30mm) 2x	5.3		(532x425x50mm) 2x
2.2		(1800x93x30mm) 1x	6.1		(990x585x40mm) 1x
2.3		(1800x93x30mm) 60x	6.2		(535x585x40mm) 1x
2.4		(1800x93x30mm) 1x	7		(520x330x65mm) 2x
3.1		(1758x575x30mm) 1x	8.1		(560x300x40mm) 1x
3.2		(1650x575x30mm) 1x	8.2		(378x300x40mm) 2x
3.3		(1758x952x30mm) 1x	9		3x obroč soda
4.1		(1404x80x20mm) 1x	10		(3000x1800mm) 1x
4.2		(1404x80x20mm) 1x	11		(1000x320mm) 60x
4.3		(1574x488x30mm) 1x	12		(250x50x45mm) 1x
4.4		(1758x783x30mm) 1x	13		(350x50x45mm) 1x
4.5		(1574x488x30mm) 1x	14		1x peč za savno
5.1		(1152x425x50mm) 2x	15		(177x80x30mm) 1x

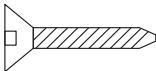
Opis savne

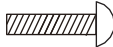
16		1x posoda za vodo	20		1x higrometer
17		2x pokrov luči	21		1x pečena ura
18		2x držalo za skodelico	22		1x zajemalka
19		1x vedro			

							
Ø5x50	Ø4x50	Ø4x30	Ø3x35	Ø4x12	Ø6x70		
44x	20x	8x	66x	240x	2x	2x	

Preden začnete, natančno preberite navodila za namestitev.

Izbira lokacije – zasnovana izključno za zunanjo postavitvev

Izberite prostor:

- V suhem prostoru, na ravni, stabilni površini, ki lahko prenese težo savne.
- Višina mora biti takšna, da lahko dosežete strop in opravite električne priključke ter vzdrževalna dela.
- Ne v bližini virov vode, plamena ali gorljivih materialov.

Praktični nasveti:

- Upoštevajte, da so za sestavo savne potrebne 3 odrasle osebe.
- Preden začnete, jasno označite vsako ploščo.
- Pri sestavljanju napajalni kabel savne napeljite tako, da bo zlahka dostopen.
- Upoštevajte, da obstajajo razlike med posameznimi modeli.

POMEMBNO :

Da ne bi poškodovali lesa, preverite globino in premer lukenj za vrtanje

Potrebno orodje



izvijač



meter



svinčnik



rezilo



2 ključ

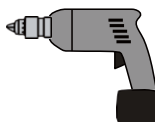

električni izvijač



sveder za les



imbus ključ



lestev

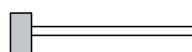



kladivo

Navodila za montažo

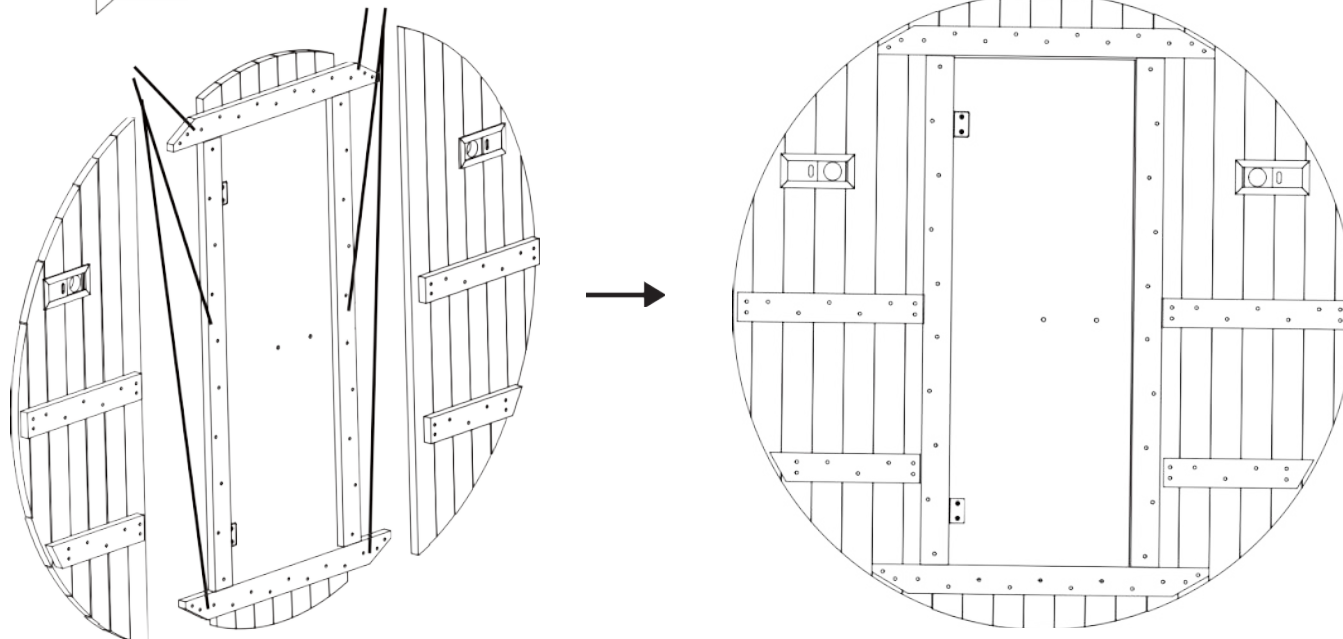
 Ø 5 x 50 20 kos

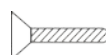

 Ø 3 x 35 2 kos

 Ø 5 x 50 18 kos

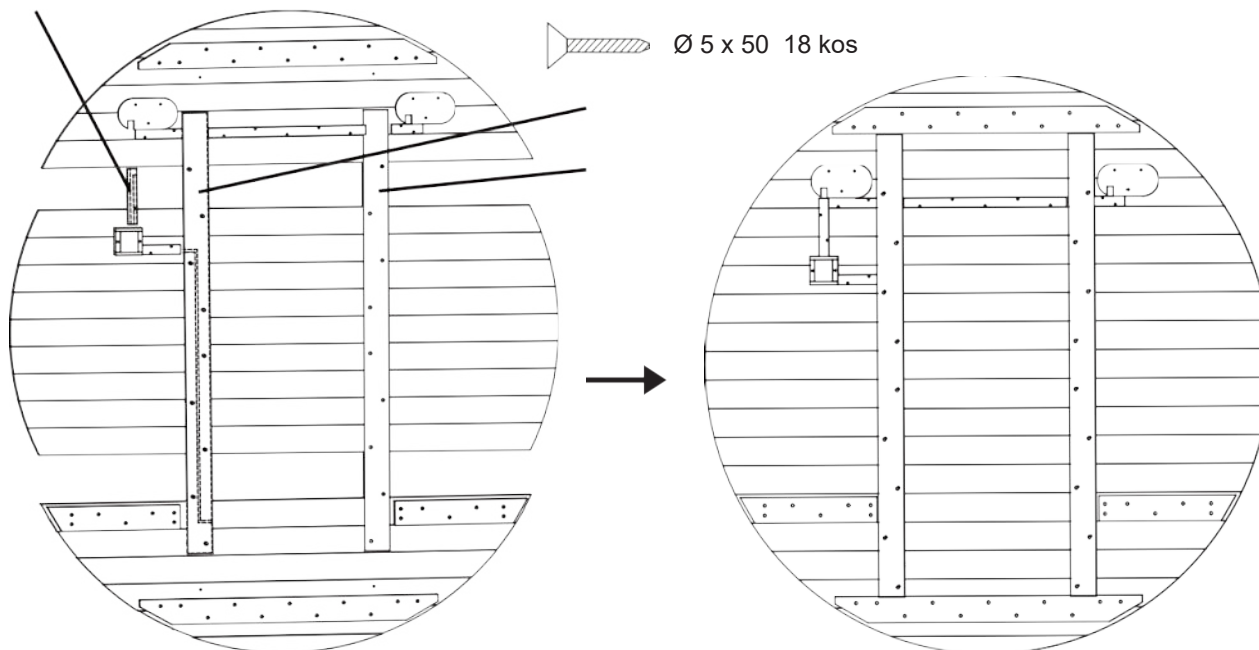

Sprednjo in zadnjo ploščo je treba najprej sestaviti kot celoto.

Sprednja plošča je razdeljena na tri dele na levi in desni strani, zadnja plošča pa je razdeljena na tri dele na zgornji in spodnji strani.

Navodila za montažo

Koraki montaže

 Ø 5 x 50 2 kos

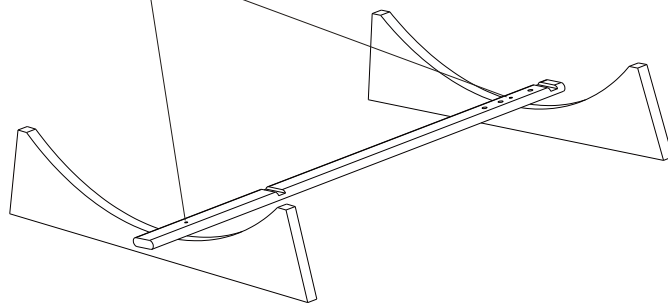

spodnja opora

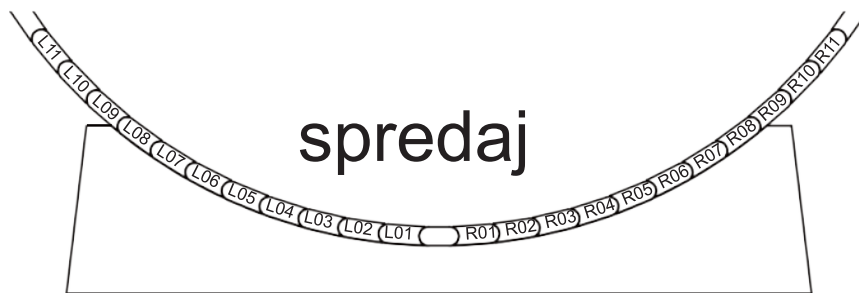
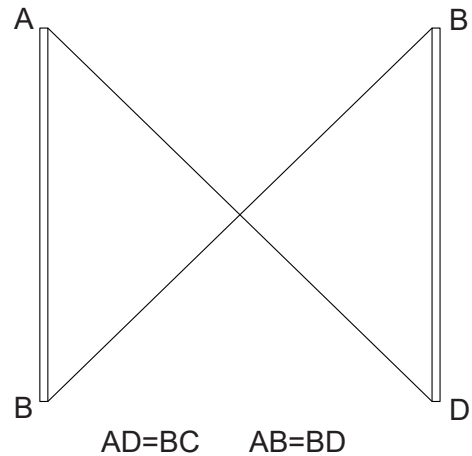

Vsaka letvica je oštevilčena in označena.

Leva stran je označena L01 L02 L03..... L38 od spodaj navzgor;

Desna stran je označena R01 R02 R03..... R38 od spodaj navzgor.

Navodila za montažo

Koraki montaže

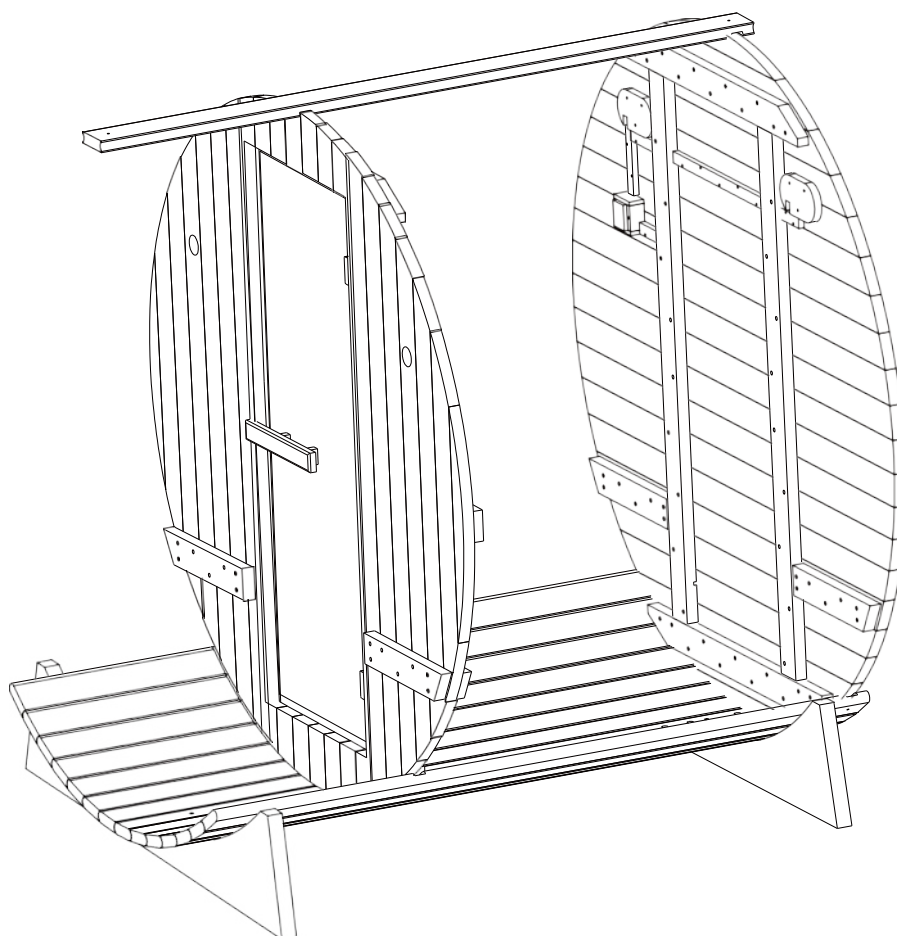
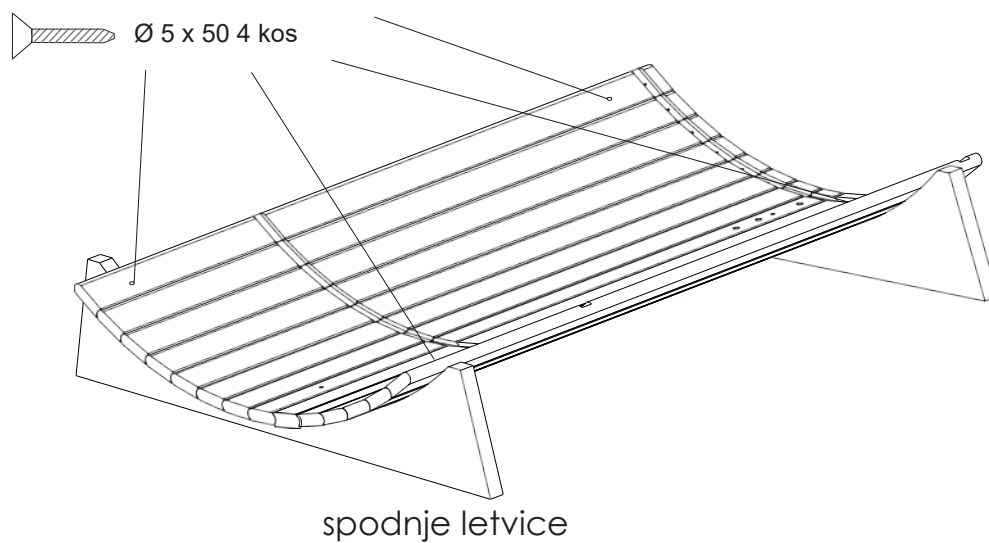

Začasno namestite zgornjo letev kot zaščitni ukrep med montažo.

Navodila za montažo

Koraki montaže

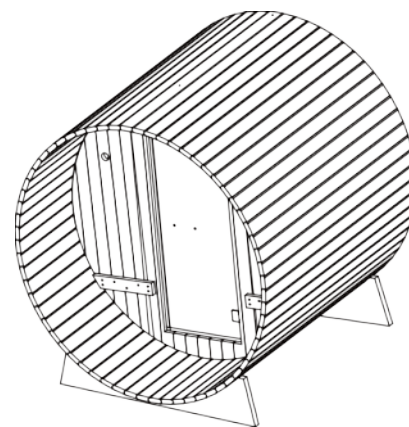
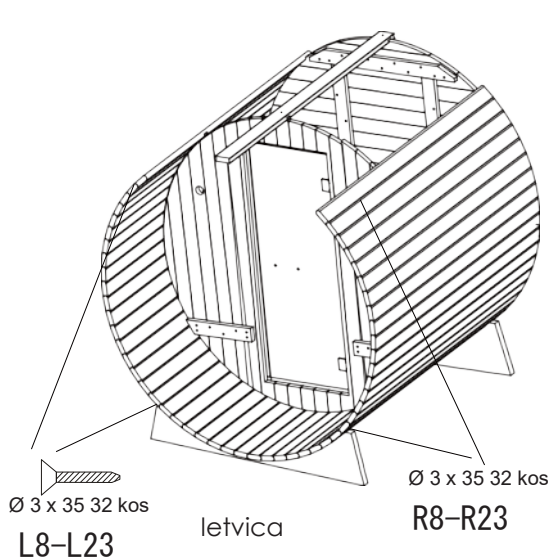

1. Spodnje letvice ohišja soda naj bodo tesno nameščene, to bo olajšalo namestitev zgornjega dela in pripomoglo k tesnosti.
2. Vijaki (M3*35, 64 kos) se uporabljajo za namestitev letvic L8-L23 in R8-R23, zgornje letvice so nameščene tesno, po oblikovanju celotnega valja je ohišje soda fiksirano s trakovi iz nerjavečega jekla.

Glede na dejanske potrebe ob montaži lahko razrahljate vijake in odstranite eno ali dve tanki plošči na sredini.

tanki plošči

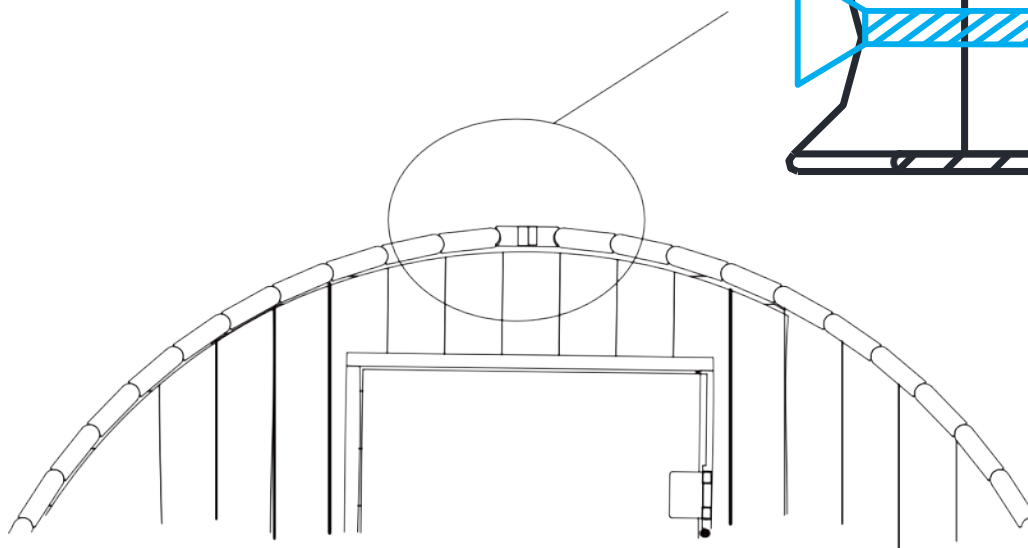
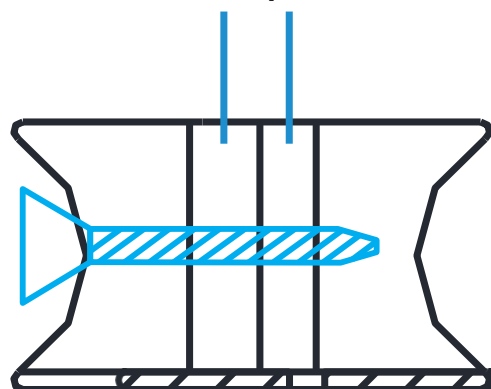

Navodila za montažo

Koraki montaže

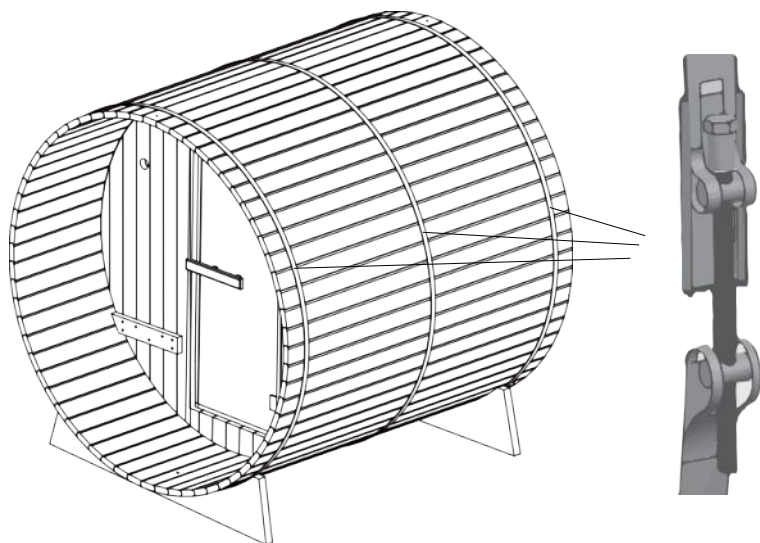

trakovi iz nerjavečega jekla

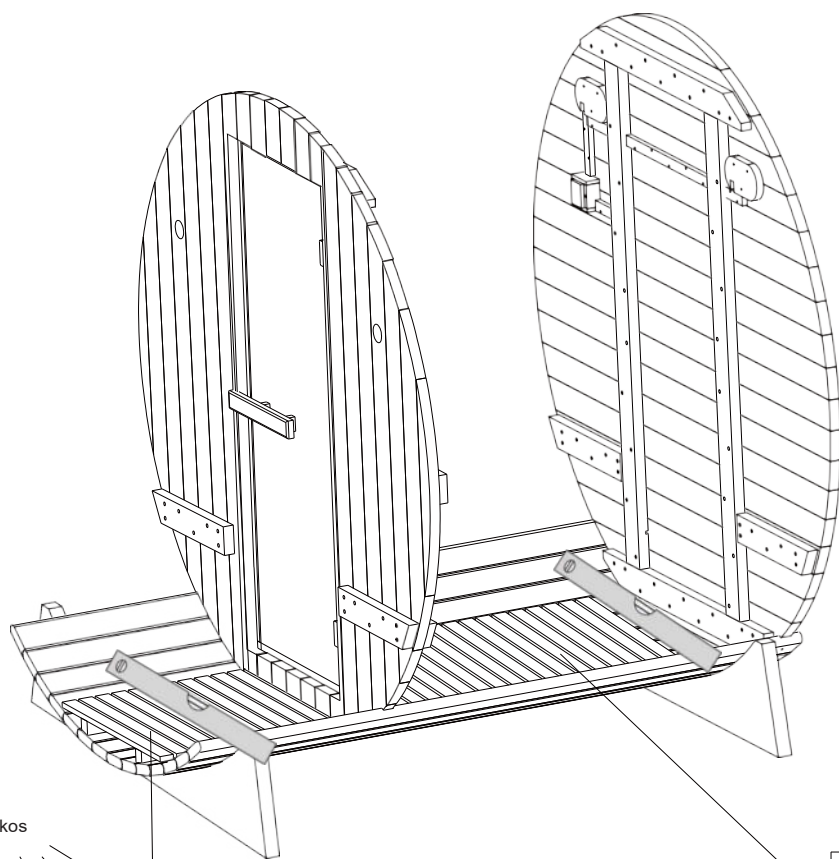

Ø 4 x 50 4 kos

Ø 4 x 50 4 kos

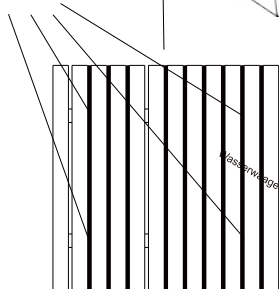

Wasserwaage

Naslon za noge

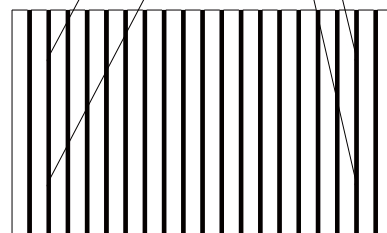

Wasserwaage

Navodila za montažo

Koraki montaže

Podpora notranjih in zunanjih sedežnih plošč je vnaprej nameščena na sprednjo in zadnjo ploščo.

Zunanja sedežna plošča potrebuje še dodatno oporo, ki se namesti z vijaki na spodnjo ploščo.

Notranja sedežna plošča ne potrebuje dodatne opore.

Zaklepne vijake sedežnih plošč je potrebno pritrditi na podpore na sprednji in zadnji plošči.

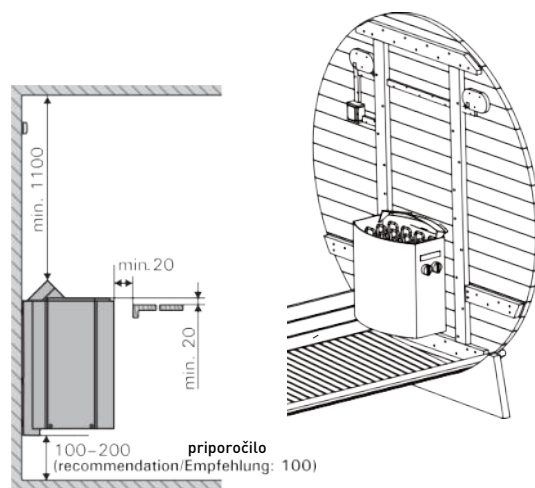
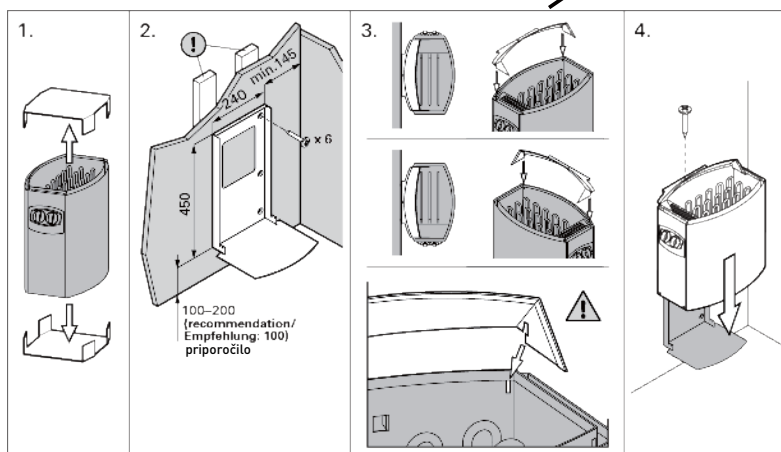
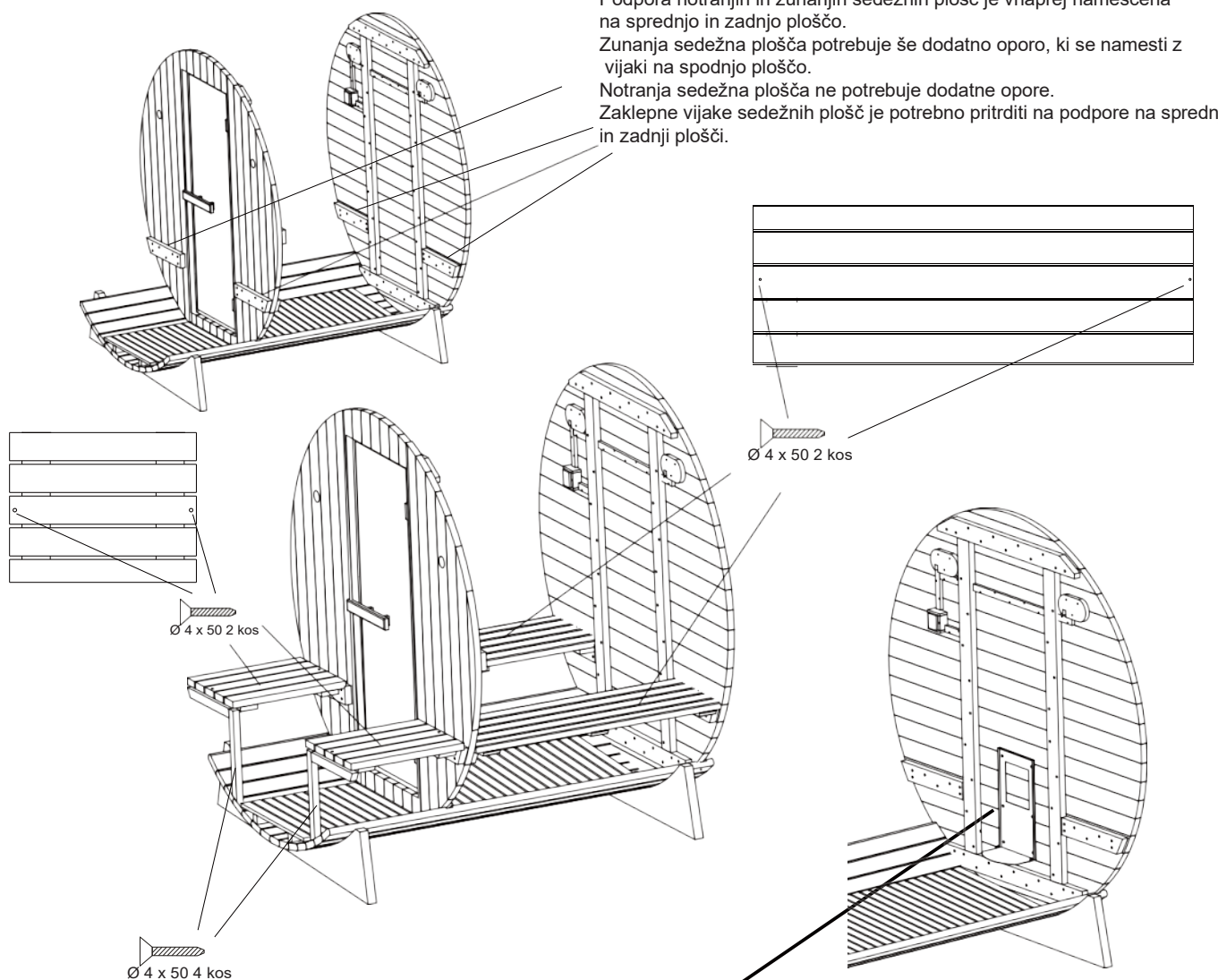

Montaža savne zahteva, da najprej namestite stenski nosilec okvirja peči, nato peč obesite. Za specifične informacije glejte shemo.

Za podrobnejše informacije preberite priročnik, ki je priložen peči za savno.

peč za savno je opremljena z univerzalnim kablom, ki je povezan z zunanjim napajalnikom. Električne kable svetilk je potrebno priključiti in na in napajati preko ožičenja peči za savno.

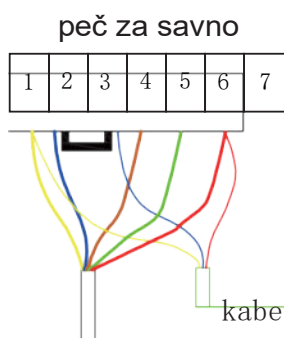
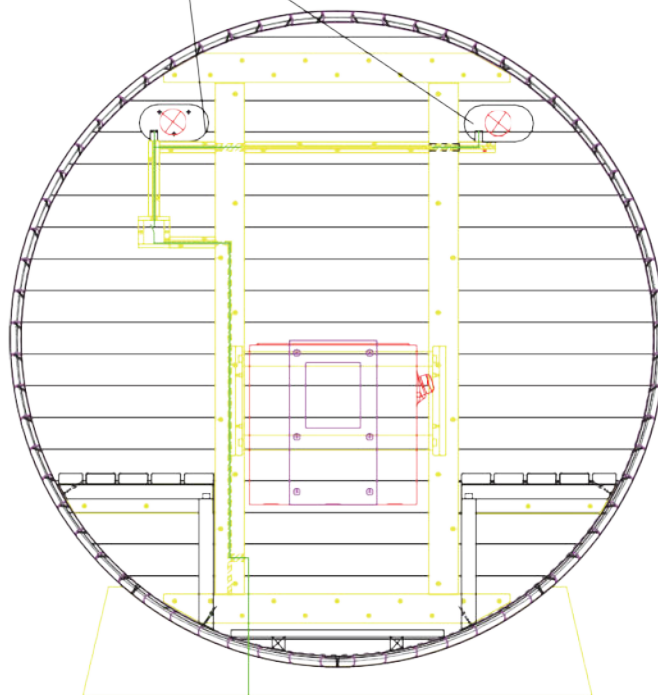
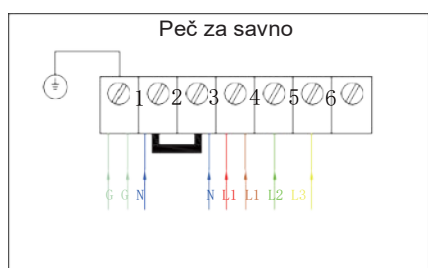
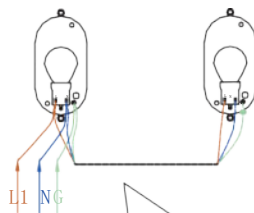

kabel
peči (5*2.5mm²)

kabel luči (3*0.75mm²)

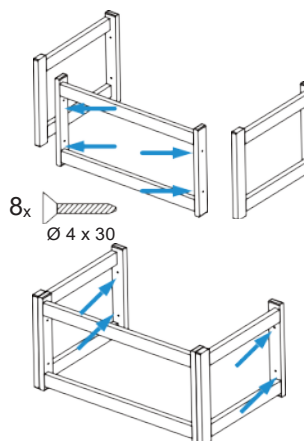
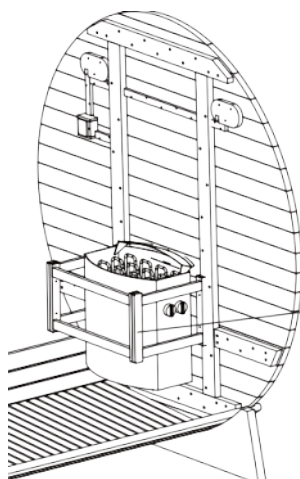

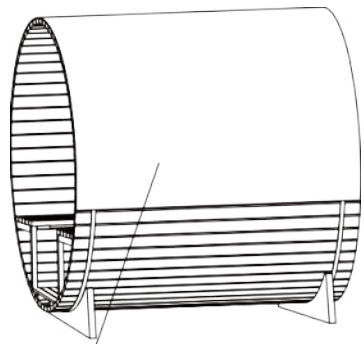

nepremočljiva tkanina

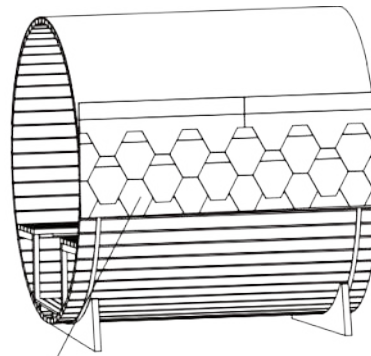

bitumenska škodla



Ø 4 x 12 200 kos

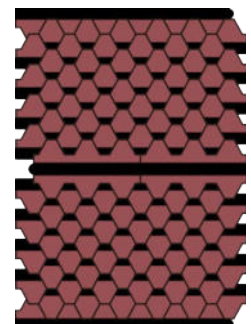
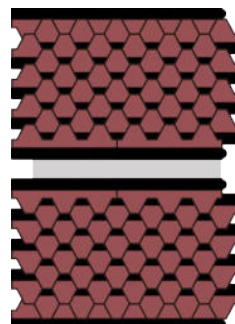
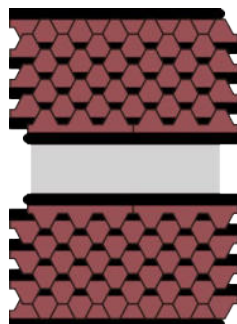
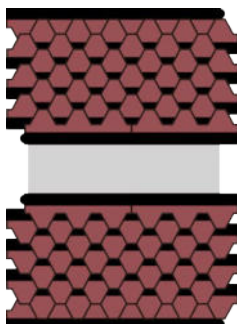
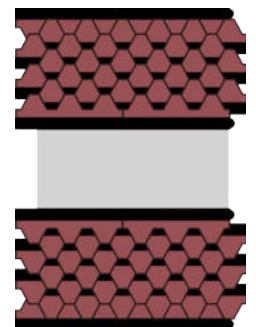
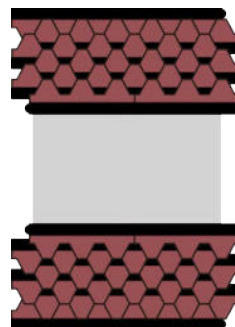
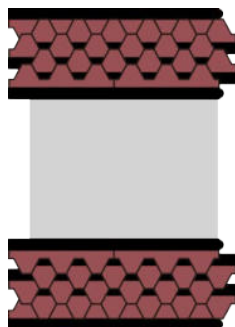
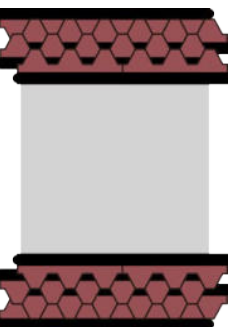
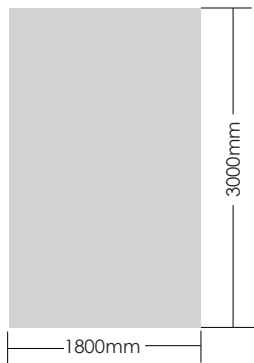

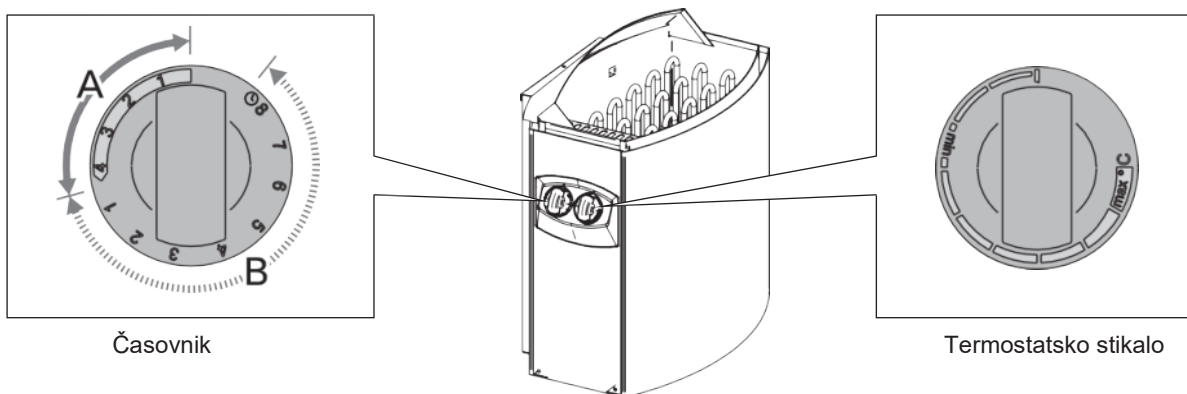

Časovnik

Termostatsko stikalo

1. Peč

vklop

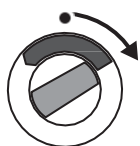

Nastavite časovnik na "on" (del A na sliki 2, 0-4 ure). Peč se začne takoj segrevati.

2. Pred-nastavljen čas (časovno nadzorovan vklop)



nastavite časovnik na del "pred-nastavitev" (del B na sliki 2, 0–8 ur). Peč se začne segrevati, ko časovnik prestavi stikalo nazaj v položaj "vklopljeno". Po tem bo grelnik vklopljen približno štiri ure.

Za podrobnejše informacije o posebni uporabi in varnostnih ukrepih za peč savne glejte navodila za uporabo, ki so priložena peči savne.

Vzdrževanje

Zaščita lesa

Ko je savna sestavljena, počistite vsako zunanjo letev soda in nanesite lazuro za les, da zaščitite les. Zaščito lesa obnavljajte v skladu s priporočili proizvajalca uporabljenega izdelka.

POMEMBNO :

Pred začetkom dela odklopite napajalni kabel kabine.

Ugotovljena težava	Možen vzrok	Rešitev
Peč se ne segreje.	Napajalni kabel ni priključen.	Preverite povezavo napajalnega kabla.
	Prekinjeno je dovajanje električne energije.	Preverite brezhibnost varovalk in preverite napetost v vtičnici.
	Peč je zaščiten pred pregrevanjem.	Glejte navodila za uporabo peči
Osvetlitev savne ne deluje več.	Napajalni kabel luči ni dobro priključen.	Pravilno priključite kabel.
	Luč je pokvarjena.	Obrnite se na prodajalca.

Čiščenje:

1. Izklopite savno.
2. S sesalnikom odstranite prah iz razpok v lesenem opažu.
3. Kabino očistite z vlažno bombažno krpo, po potrebi z majhno količino mila. Izperite z vlažno krpo.
4. Steklo očistite s čistilom za okna/stekla in mehko krpo.
5. Zunanost savne negujte vsaki 2 leti z ustreznim sredstvom.

POMEMBNO :

Les je treba z zaščitnim sredstvom obdelati samo na zunanji strani savne. Notranjosti savne se ne sme obdelovati.

Za savno ne uporabljajte benzena, alkohola, kemikalij ali močnih čistil, saj lahko kemični izdelki poškodujejo les. Ne pršite svoje savne z vodo.

Za namestitev in uporabo grelnika savne preberite priložena navodila.

Grelec lahko na električno omrežje priključi le pooblaščen električar v skladu z veljavnimi predpisi.

BC45, BC60, BC80, BC90 BC45E, BC60E, BC80E, BC90E

EN Instructions for Installation and Use of Electric Sauna Heater

SI Navodila za uporabo in montažo električnega grelnika / peči
savne



these instructions for installation and use are intended for the owner or the person in charge of the sauna, as well as for the electrician in charge of the electrical installation of the heater. After completing the installation, the person in charge of the installation should give these instructions to the owner of the sauna or to the person in charge of its operation. Please read the instructions for use carefully before using the heater.

the heater is designed for the heating of a sauna room to bathing temperature. It is not to be used for any other purpose.

Congratulations on your choice!

Guarantee:

- the guarantee period for heaters and control equipment used in saunas by families is two (2) years.
- the guarantee period for heaters and control equipment used in saunas by building residents is one (1) year.
- the guarantee does not cover any faults resulting from failure to comply with installation, use or maintenance instructions.
- the guarantee does not cover any faults resulting from the use of stones not recommended by the heater manufacturer.

ContEntS

1. InStRUCtIoNS FoR USE	3
1.1. Piling of the Sauna Stones	3
1.1.1. Maintenance.....	3
1.2. Heating of the Sauna.....	4
1.3. Using the Heater.....	4
1.3.1. Heater On.....	4
1.3.2. Pre-setting Time (timed switch-on).....	4
1.3.3. Heater Off.....	5
1.3.4. Setting the Temperature.....	5
1.4. Throwing Water on Heated Stones.....	5
1.5. Instructions for Bathing	6
1.6. Warnings.....	6
1.7. Troubleshooting	6
2. SAUnA RoOm	8
2.1. Sauna Room Structure	8
2.1.1. Blackening of the sauna walls.....	8
2.2. Sauna Room Ventilation	9
2.3. Heater Output	9
2.4. Sauna Room Hygiene	9
3. InStRUCtIoNS FoR InStALLAtIoN	10
3.1. Before Installation.....	10
3.2. Fastening the Heater on a Wall	11
3.3. Electrical Connections	12
3.3.1. Electric Heater Insulation Resistance	12
3.4. Installation of the Control Unit and Sensors (BC-E) ..	13
3.5. Resetting the Overheat Protector	13
4. SPARE PARTS	15

Ta navodila za montažo in uporabo so namenjena lastniku savne oziroma osebi, odgovorni za vzdrževanje savne, ter električarju, odgovornemu za montažo grelnika savne. Ob montaži grelnika savne se ta navodila za montažo in uporabo izročijo lastniku savne oziroma osebi, odgovorni za oskrbo savne. Pred uporabo peči za savno natančno preberite navodila za uporabo.

Peč se uporablja za ogrevanje savna kabine na temperaturo savne. Uporaba v druge namene je prepovedana. Grelniki za savne, ki imajo oznako CE, ustrezajo vsem predpisom za sisteme savn. Pristojni organi preverjajo, ali se ti predpisi upoštevajo.

Čestitamo vam za dobro izbiro!

Garancija:

- Garancijska doba za grelnike in regulatorje savn, ki se uporabljajo v družinskih savnah, je dve (2) leti.
- Garancijska doba za grelnike in regulatorje savn, ki se uporabljajo v javnih savnah v zasebnih zgradbah, je eno (1) leto.
- Garancija ne pokriva okvar, ki nastanejo zaradi nepravilne namestitve in uporabe ali neupoštevanja navodil za vzdrževanje.
- Garancija ne pokriva škode, povzročene z uporabo kamnov, ki niso priporočeni s strani tovarne.

VSEBINA

1. NAVODILA ZA UPORABO	3
1.1. Zlaganje kamnov za savno.....	3
1.1.1. Vzdrževanje	3
1.2. Segrevanje savne	4
1.3. Uporaba peči	4
1.3.1. Vklon peči.....	4
1.3.2. Prednastavljeni čas (časovno nadzorovan vklop)	4
1.3.3. Izklon peči.....	5
1.3.4. Nastavitev temperature.....	5
1.4. Polivanje vode na segrete kamne	5
1.5. Navodila za uporabo savne	6
1.6. Opozorila	6
1.7. Okvare	6
2. SAVNA	8
2.1. Struktura savne	8
2.1.1. Počrnitev sten savne	8
2.2. Prezračevanje savne	9
2.3. Moč peči	9
2.4. Čistoča in higiena v savni	9
3. NAVODILA ZA NAMESTITVE	10
3.1. Pred montažo	10
3.2. Pritrditev peči na steno	11
3.3. Električni priključki.....	12
3.3.1. Izolacijska odpornost električne peči za savno.....	12
3.4. Priključitev krmilne enote in seznojcev (BC-E)	13
3.5. Ponastavitev zaščite pred pregrevanjem	13
4. REZERVNI DELI	15

1. InStRUCtIOnS FoR USE

1.1. Piling of the Sauna Stones

The piling of the sauna stones has a great effect on the functioning of the heater (figure 1).

Important information on sauna stones:

- The stones should be 5–10 cm in diameter.
- Use solely angular split-face sauna stones that are intended for use in a heater. Peridotite, olivine-dolerite and olivine are suitable stone types.
- **neither light, porous ceramic "stones" nor soft soapstones should be used in the heater. they do not absorb enough heat when warmed up. this can result in damage in heating elements.**
- Wash off dust from the stones before piling them into the heater.

Please note when placing the stones:

- Do not drop stones into the heater.
- Do not wedge stones between the heating elements.
- Place the stones sparsely to ensure that air can circulate between them.
- Pile the stones so that they support each other instead of lying their weight on the heating elements.
- Do not form a high pile of stones on top of the heater.
- No such objects or devices should be placed inside the heater stone space or near the heater that could change the amount or direction of the air flowing through the heater.

1. NAVODILA ZA UPORABO

1.1. Zlaganje kamnov za savno

Način zlaganja kamnov v peč močno vpliva na učinkovitost peči (foto. 1).

Pomembne informacije o kamnih za peč savne:

- Kamni morajo imeti premer 5-10 cm.
- Uporabljajte samo koničaste kamne za savno z grobo površino, ki so namenjeni za uporabo v savna pečeh. Primerni kamni so peridotit, olivin dolerit in olivin.
- **V savna peči ne smete uporabljati lahkih poroznih kamnov, keramičnih kamnov ipd., saj pri segrevanju ne absorbirajo dovolj toplote, kar lahko poškoduje grelne elemente.**
- Pred zlaganjem kamnov je treba z njih odstraniti kamniti prah.

Pri nameščanju kamnov upoštevajte naslednje:

- Kamnov ne mečite v peč.
- Ne vstavljajte kamnov med grelne elemente.
- Kamne razporedite tako, da se med njimi lahko pretaka zrak.
- Kamne položite enega na drugega tako, da ne pritiskajo na grelne elemente.
- Kamnov ne zlagajte na visok kup na vrhu peči.
- V kamniti komori ali v bližini peči ne sme biti predmetov ali naprav, ki spreminjajo količino ali smer zračnega toka skozi savno.

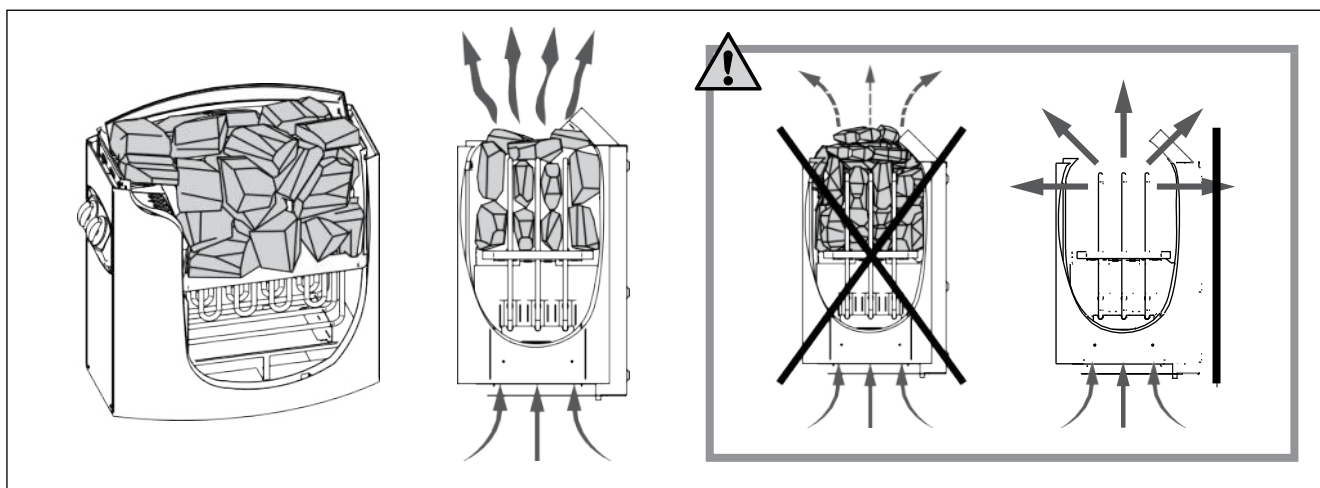

Figure 1. Piling of the sauna stones
Foto 1. Zlaganje kamnov za savno

1.1.1. Maintenance

Due to large variation in temperature, the sauna stones disintegrate in use. Rearrange the stones at least once a year or even more often if the sauna is in frequent use. At the same time, remove any pieces of stones from the bottom of the heater and replace any disintegrated stones with new ones. By doing this, the heating capability of the heater stays optimal and the risk of overheating is avoided.

1.1.1. Vzdrževanje

Kamni v savni zaradi velikih temperaturnih sprememb postanejo krhki in lomljivi. Kamne je treba na novo zložiti vsaj enkrat na leto, ob redni uporabi tudi pogosteje. V tem času odstranite tudi prah in kamnite okruške s spodnjega dela savne ter zamenjajte poškodovane kamne. S tem boste ohranili optimalno grelno zmogljivost peči in se izognili nevarnosti pregrevanja.

1.2. Heating of the Sauna

When operating the heater for the first time, both the heater and the stones emit smell. To remove the smell, the sauna room needs to be efficiently ventilated.

If the heater output is suitable for the sauna room, it will take about an hour for a properly insulated sauna to reach the required bathing temperature (2.3.). The sauna stones normally reach the bathing temperature at the same time as the sauna room. A suitable temperature for the sauna room is about 65–80 °C.

1.3. Using the Heater

Before switching the heater on always check that there isn't anything on top of the heater or inside the given safety distance. 1.6.

- Heater models BC45, BC60, BC80 and BC90 are equipped with a timer and a thermostat. The timer is for setting the on-time for the heater and the thermostat is for setting a suitable temperature. 1.3.1.–1.3.4.
- Heater models BC45E, BC60E, BC80E and BC90E are controlled from a separate control unit. See the instructions for use of the selected control unit model.

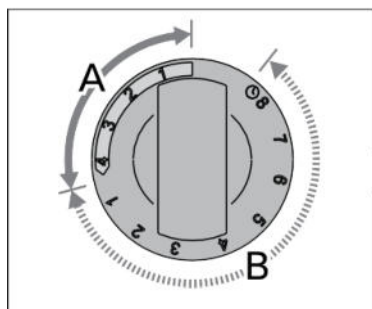

Figure 2. Timer switch
Foto 2. Časovno stikalo

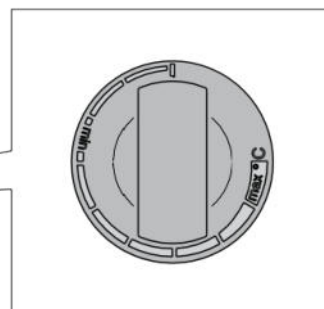
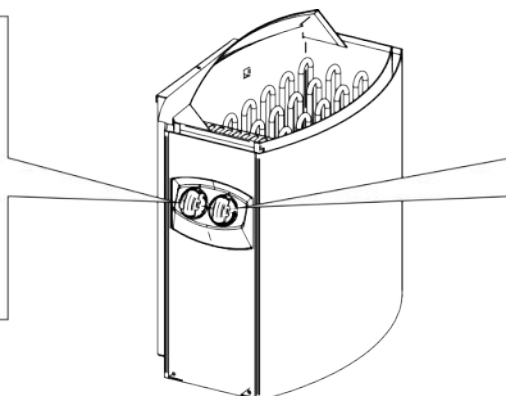

Figure 3. Thermostat switch
Foto 3. Termostat

1.3.1. Heater on



Turn the timer switch to the "on" section (section A in figure 2, 0–4 hours). The heater starts heating immediately.

1.3.2. Pre-setting time (timed switch-on)



Turn the timer switch to the "pre-setting" section (section B in figure 2, 0–8 hours). The heater starts heating when the timer has turned the switch back to the "on" section. After this, the heater will be on for about four hours.

Example: You want to go walking for three hours and have a sauna bath after that. Turn the timer switch to the "pre-setting" section at number 2.

The timer starts. After two hours, the heater starts heating. Because it takes about one hour for the sauna to be heated, it will be ready for bathing after about three hours, that is, when you come back from your walk.

1.2. Segrevanje savne

Ob prvem segrevanju se iz grelnika in kamnov savne sproščajo vonjave. Da bi jih odpravili, je treba savno temeljito prezračiti.

Če je moč grelnika primerna za prostor savne, bo ustrezno izolirana savna potrebovala približno eno uro, da bo dosegla zahtevano temperaturo za savnanje (2.3.). Kamni za savne se običajno segrejejo na temperaturo infuzije v istem času kot kabina savne. Primerna temperatura v kabini savne je približno 65 do 80 °C.

1.3. Uporaba peči

Preden vklopite peč, preverite, da na peči ali v njeni neposredni bližini ni nobenih predmetov. 1.6.

- Modeli peči BC45, BC60, BC80 in BC90 so opremljeni s časovnikom in termostatom. Časovnik uravnava čas vklopa peči, termostat pa temperaturo. 1.3.1.–1.3.4.
- Modeli peči BC45E, BC60E, BC80E in BC90E se upravljajo z ločeno krmilno enoto. Upoštevajte navodila za uporabo, ki so priložena krmilni enoti.

1.3.1. Vklop peči



Nastavite stikalo časovnika v položaj "on" (Oddelek A in foto. 2, 0–4 ur). Peč se takoj prične segrevati.

1.3.2. Prednastavljeni čas (časovno nadzorovan vklop)



Stikalo časovnika nastavite v položaj "predizbira". (oddelek B in foto. 2, 0–8 ur). Peč se prične segrevati, ko se časomer obrne na "on". Potem peč ostane vklopljena približno štiri ure.

Primer: Želite se tri ure sprehajati in se nato savnati v savni. Nastavite stikalo časovnika v razdelku "Predizbira" na številko 2.

Časomer začne delovati. Po dveh urah se začne grelnik segrevati. Ker savna potrebuje približno eno uro, da se segreje, bo pripravljena za savnanje po približno treh urah, tj. ko se boste vrnili s sprehoda.

1.3.3. Heater off



The heater switches off, when the timer turns the switch back to zero. You can switch the heater off at any time by turning the timer switch to zero yourself.

Switch the heater off after bathing. Sometimes it may be advisable to leave the heater on for a while to let the wooden parts of the sauna dry properly.

notE! Always check that the heater has switched off and stopped heating after the timer has turned the switch to zero.

1.3.4. Setting the temperature

The purpose of the thermostat (figure 3) is to keep the temperature in the sauna room on a desired level. By experimenting, you can find the setting that suits you best.

Begin experimenting at the maximum position. If, during bathing, the temperature rises too high, turn the switch counter-clockwise a little. Note that even a small difference within the maximum section will change the temperature of the sauna considerably.

1.4. throwing Water on Heated Stones

The air in the sauna room becomes dry when warmed up. Therefore, it is necessary to throw water on the heated stones to reach a suitable level of humidity in the sauna. The effect of heat and steam on people varies – by experimenting, you can find the levels of temperature and humidity that suit you best.

notE! the maximum volume of the ladle is 0.2 litres. If an excessive amount of water is poured on the stones, only part of it will evaporate and the rest may splash as boiling hot water on the bathers. never throw water on the stones when there are people near the heater, because hot steam may burn their skin.

notE! the water to be thrown on the heated stones should meet the requirements of clean household water (table 1). only special aromas designed for sauna water may be used. Follow the instructions given on the package.

1.3.3. Izklop peči



Peč se izklopi, ko se časovnik vrne nazaj na ničlo. Peč lahko kadar koli izklopite sami, z nastavitvijo stikala na časovniku na nič. Po savnanju izklopite peč

Včasih je priporočljivo pustiti peč še nekaj časa prižgano, da se leseni deli savne ustrezno posušijo.

POZOR! Vedno se prepričajte, da je peč izklopljena in se ne segreva več, ko se časovnik prestavi nazaj na ničlo.

1.3.4. Nastavitev temperature

Namen termostata (Foto. 3) je vzdrževati željeno temperaturo v savni. Preizkusite, katera nastavitev vam najbolj ustreza.

Začnite z najvišjo nastavitvijo. Če se temperatura med savnanjem dvigne previsoko, obrnite stikalo nekoliko v nasprotni smeri urinega kazalca. Upoštevajte, da v zgornjem temperaturnem območju že majhne spremembe močno vplivajo na temperaturo v savni.

1.4. Polivanje vode na segrete kamne

Zrak v savni se pri segrevanju izsuši, zato je treba na vroče kamne savne polivati vodo, da se doseže prijetna raven vlažnosti. Učinki toplote in pare se razlikujejo od osebe do osebe zato preizkusite katera temperatura in stopnja vlažnosti sta za vas najboljši.

POZOR! Prostornina zajemalke za polivanje vode ne sme presegati 0,2 litra. Na kamne ne vlivajte večjih količin vode naenkrat, saj bi lahko vrela voda ob izhlapevanju brizgnila na ljudi v savni. Prav tako pazite, da vode ne zlijete na kamne, ko je kdo v njihovi bližini. Vroča para lahko povzroči opekline.

POZOR! Za polivanje se sme uporabljati samo voda, ki ustreza zahtevam glede kakovosti za gospodinjsko vodo (preglednica 1). V vodi za polivanje se lahko uporabljajo samo za ta namen določene dišave. Upoštevajte navodila na embalaži.

Water property Lastnost vode	Effect Učinek	Recommendation Priporočilo
Humus concentration Vsebnost humusa	Colour, taste, precipitates Barva, okus, usedline	<12 mg/l
Iron concentration Vsebnost železa	Colour, odour, taste, precipitates Barva, vonj, okus, usedline	<0,2 mg/l
Hardness: most important substances are manganese (Mn) and lime, i.e. calcium (Ca). Trdota vode: Najpomembnejši snovi sta mangan (Mn) in vodni kamen, tj. kalcij (Ca).	Precipitates Usedline	Mn: <0,05 mg/l Ca: <100 mg/l
Chlorinated water Klorirana voda	Health risk Škodljivo za zdravje	Forbidden to use Se ne sme uporabljati
Seawater Slana voda	Rapid corrosion Hitra korozija	Forbidden to use Se ne sme uporabljati

Table 1. Water quality requirements
Tabela 1. Zahteve glede kakovosti vode

1.5. Instructions for Bathing

- Begin by washing yourself.
- Stay in the sauna for as long as you feel comfortable.
- Forget all your troubles and relax.
- According to established sauna conventions, you must not disturb other bathers by speaking in a loud voice.
- Do not force other bathers from the sauna by throwing excessive amounts of water on the stones.
- Cool your skin down as necessary. If you are in good health, you can have a swim if a swimming place or pool is available.
- Wash yourself after bathing.
- Rest for a while and let your pulse go back to normal. Have a drink of fresh water or a soft drink to bring your fluid balance back to normal.

1.6. Warnings

- **Staying in the hot sauna for long periods of time makes the body temperature rise, which may be dangerous.**
- **Keep away from the heater when it is hot. the stones and outer surface of the heater may burn your skin.**
- **Keep children away from the heater.**
- **Do not let young, handicapped or ill people bathe in the sauna on their own.**
- **Consult your doctor about any health-related limitations to bathing.**
- **Consult your child welfare clinic about taking little babies to the sauna.**
- **Be very careful when moving in the sauna, as the platform and floors may be slippery.**
- **never go to a hot sauna if you have taken alcohol, strong medicines or narcotics.**
- **never sleep in a hot sauna.**
- **Sea air and a humid climate may corrode the metal surfaces of the heater.**
- **Do not hang clothes to dry in the sauna, as this may cause a risk of fire. Excessive moisture content may also cause damage to the electrical equipment.**

1.7. troubleshooting

note! All service operations must be done by professional maintenance personnel.

the heater does not heat.

- Check that the fuses to the heater are in good condition.
- Check that the connection cable is connected (▶ 3.3.).
- Turn the timer switch to the "on" section (▶ 1.3.1.).
- Turn the thermostat to a higher setting (▶ 1.3.4.).
- Check that the overheat protector has not gone off. The timer works but the heater does not heat. (▶ 3.5.)

the sauna room heats slowly. the water thrown on the sauna stones cools down the stones quickly.

- Check that the fuses to the heater are in good

1.5. Navodila za uporabo savne

- Pred savnanjem se stuširajte.
- V savni ostanite toliko časa, kolikor vam je prijetno.
- Pozabite na stres in se sprostite.
- Med dobre navade v savni sodi tudi obzirnost do drugih, tako da jih ne vznemirjate z nepotrebnim hrupom.
- Bodite obzirni do drugih in ne polivajte kamnov prevečkrat.
- Vmes počakajte, da se segreta koža ohladi. Če ste dobrega zdravja in imate možnost, pojdite plavat.
- Po savnanju se stuširajte.
- Počivajte, dokler se ne počutite uravnoveženo. Pijte čisto vodo ali brezalkoholno pijačo, da uravnovesite ravnovesje tekočin.

1.6. Opozorila

- Dolgotrajno zadrževanje v vroči savni povzroči povišanje telesne temperature, kar je lahko nevarno.
- Pazite na vroče grelnike savne. Kamni in ohišje so zelo vroči in lahko opečejo kožo.
- Otrokom prepričajte dostop do peči.
- Otroci, osebe s težavami pri hoji, bolni in šibki ne smejo ostati sami v savni.
- O zdravstvenih omejitvah v zvezi s savnanjem se je treba posvetovati z zdravnikom.
- O savnanju malih otrok se posvetujte z otroškim zdravnikom.
- Ne hodite v savno, če ste pod vplivom mamil, alkohola, zdravil, droge itd..
- Nikoli ne spite v ogrevani savni.
- Morje in vlažno podnebje lahko povzročita rjavenje kovinskih površin peči v savni.
- Savne ne uporabljajte za sušenje oblačil ali perila, saj obstaja nevarnost požara; poleg tega lahko visoka vlažnost poškoduje električne naprave.

1.7. Okvare

Pozor! Vsa vzdrževalna dela mora opravljati usposobljeno tehnično osebje.

Peč se ne segreje.

- Prepričajte se, da so varovalke v peči v dobrem stanju.
- Preverite, ali je priključni kabel priključen (3.3.).
- Nastavite stikalo časovnika v položaj "on" (1.3.1.).
- Nastavite termostat na višjo vrednost (1.3.4.).
- Preverite, ali se je sprožila zaščita pred pregrevanjem. Časovnik deluje, vendar se peč ne segreje. (3.5.)

Kabina savne se segreva prepočasi. Voda, ki se zlije na kamne savne, jih hitro ohladi.

condition.

- Check that all heating elements glow when the heater is on.
- Turn the thermostat to a higher setting (▶ 1.3.4.).
- Check that the heater output is sufficient (▶ 2.3.).
- Check the sauna stones (▶ 1.1.). Too tightly piled stones, the settling of stones with time or wrong stone type can hinder the air flow through the heater, which results in reduced heating efficiency.
- Check that the sauna room ventilation has been arranged correctly (▶ 2.2.).

the sauna room heats quickly, but the temperature of the stones remain insufficient. Water thrown on the stones runs through.

- Turn the thermostat to a lower setting (▶ 1.3.4.).
- Check that the heater output is not too high (▶ 2.3.).
- Check that the sauna room ventilation has been arranged correctly (▶ 2.2.).

the sauna room heats unevenly.

- Check that the heater has been installed in the correct height. The heater heats the sauna best, when it is installed 100 mm from the floor. The maximum installation height is 200 mm. (▶ 3.2.)

Panel or other material near the heater blackens quickly.

- Check that the requirements for safety distances are fulfilled (▶ 3.1.).
- Check the sauna stones (▶ 1.1.). Too tightly piled stones, the settling of stones with time or wrong stone type can hinder the air flow through the heater, which may result in overheating of surrounding materials.
- Also see section 2.1.1.

the heater emits smell.

- See section 1.2.
- The hot heater may emphasize odours mixed in the air that are not, however, caused by the sauna or the heater. Examples: paint, glue, oil, seasoning.

the heater makes noise.

- BC: The timer is a mechanical device and it makes a ticking sound when it is functioning normally. If the timer ticks even when the heater is switched off, check the timer's wiring.
- Occasional bangs are most likely caused by stones cracking due to heat.
- The thermal expansion of heater parts can cause noises when the heater warms up.

- Prepričajte se, da so varovalke v peči v dobrem stanju.
- Prepričajte se, da vsi grelni elementi žarijo, ko je peč vklopljena.
- Nastavite termostat na višjo vrednost (1.3.4.).
- Preverite, ali je moč peči zadostna (2.3.).
- Preverite kamne v peči (▶ 1.1.). Preveč tesno nalaganje kamnov, posedanje kamnov in napačne vrste kamnov, lahko ovirajo pretok zraka skozi peč, zaradi česar se zmanjša učinkovitost ogrevanja.
- Prepričajte se, da je v savni pravilno nastavljeno prezračevanje (▶ 2.2.).

Savna se hitro segreje, vendar je temperatura kamnov nezadostna. Voda, ki se zlije na kamne, teče skozi.

- Nastavite termostat na nižjo vrednost (1.3.4.).
- Preverite, da moč peči ni previsoka (2.3.).
- Prepričajte se, da je prezračevanje kabine savne pravilno nastavljeno (2.2.).

Savna se segreva neenakomerno.

- Prepričajte se, da je peč postavljena na pravo višino. Peč najbolje ogreje savno, če je postavljena 100 mm nad tlemi. Največja višina namestitve je 200 mm. (▶ 3.2.)

Paneli in drugi materiali ob peči hitro počrni.

- Preverite, ali so izpolnjene zahteve glede varnostnih razdalj (3.1.).
- Preverite kamne v peči (1.1.). Preveč tesno naložen kamni, posedanje kamnov in napačni kamni lahko ovirajo pretok zraka skozi peč, zaradi česar lahko pride do pregrevanja materialov v bližini.
- Poglej tudi 2.1.1.

Peč oddaja neprijetne vonjave.

- Poglej 1.2.
- Vročna peč lahko poveča vonjave v zraku, ki jih jih ne povzroča savna ali peč sama. Primeri: barve, lepilo, olje, začimbe.

Peč povzroča hrup.

- BC: Časomer je mehanska naprava, zato pri normalnem delovanju oddaja zvok tiktakanja. Če se tiktakanje sliši, čeprav peč ni vklopljena, preverite povezave časovnika.
- Nenadno pokanje je včasih posledica tega, da kamni počijo zaradi vročine.
- Raztezanje delov peči zaradi toplote lahko povzroči hrup, ko se peč segreje.

2. SAUNA ROOM

2. SAVNA

2.1. Sauna Room Structure

2.1. Struktura savne

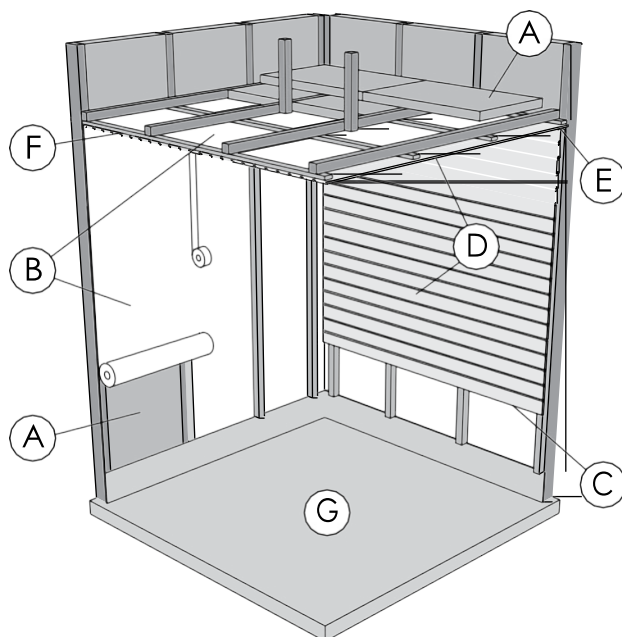

Figure 4.
Foto 4.

- A. Insulation wool, thickness 50–100 mm. The sauna room must be insulated carefully so that the heater output can be kept moderately low.
- B. Moisture protection, e.g. aluminium paper. Place the glossy side of the paper towards the sauna. Tape the seams with aluminium tape.
- C. Vent gap of about 10 mm between the moisture protection and panel (recommendation).
- D. Low mass 12–16 mm thick panel board. Before starting the panelling, check the electric wiring and the reinforcements in the walls required by the heater and benches.
- E. Vent gap of about 3 mm between the wall and ceiling panel.
- F. The height of the sauna is usually 2100–2300 mm. The minimum height depends on the heater (see table 2). The space between the upper bench and ceiling should not exceed 1200 mm.
- G. Use floor coverings made of ceramic materials and dark joint grouts. Particles disintegrating from the sauna stones and impurities in the sauna water may stain and/or damage sensitive floor coverings.

notE! Check from the fire authorities which parts of the firewall can be insulated. Flues which are in use must not be insulated.

notE! Light protective covers which are installed directly to the wall or ceiling may be a fire risk.

2.1.1. Blackening of the sauna walls

It is perfectly normal for the wooden surfaces of the sauna room to blacken in time. The blackening may be accelerated by

- sunlight
- heat from the heater
- protective agents on the walls (protective agents have a poor heat resistance level)
- fine particles disintegrating from the sauna stones which rise with the air flow.

- A. Izolacijska volna, debeline 50-100 mm. Kabino savne je treba skrbno izolirati, da peči ni treba zagotavljati prevelike moči.
- B. Zaščita pred vlago, npr. aluminijast papir. Svetleča stran papirja mora biti obrnjena proti savni. Zatesnite šive z aluminijastim trakom.
- C. Približno 10 mm zraka med zaščito pred vlago in oblogo (priporočilo).
- D. Lahka, 12-16 mm debela obloga. Pred začetkom oblaganja preverite električno napeljavo in potrebne ojačitve za peč in klopi v stenah.
- E. Približno 3 mm zraka med stensko in stropno oblogo.
- F. Višina savne je običajno 2100-2300 mm. Najmanjša višina je odvisna od peči (glejte preglednico 2). Razdalja med zgornjo klopijo in stropom mora biti največ 1200 mm.
- G. Uporabite keramične talne obloge in temno fugirno maso. Delci, ki uhajajo iz sesalnih kamnov, in nečistoče v vodi lahko razbarvajo ali poškodujejo občutljiva tla. **POZOR! Pri pristojnih organih se pozanimajte, kateri del ognjevarne stene je mogoče izolirati. Dimnikov, ki so v uporabi, ni dovoljeno izolirati. POZOR! Lahki zaščitni pokrovi, pritrjeni neposredno na steno ali strop, predstavljajo požarno tveganje.**

2.1.1. Počrnitev sten savne

Povsem normalno je, da se lesene površine savne sčasoma obarvajo. Črnitev pospešujejo:

- sončna svetloba
- Vročina peči
- Zaščita oblog na stenah (z nizko toplotno odpornostjo)
- Drobnih delci, ki uhajajo v zrak iz razpadajočih kamnov savne.

2.2. Sauna Room Ventilation

The air in the sauna room should change six times per hour. Figure 5 illustrates different sauna room ventilation options.

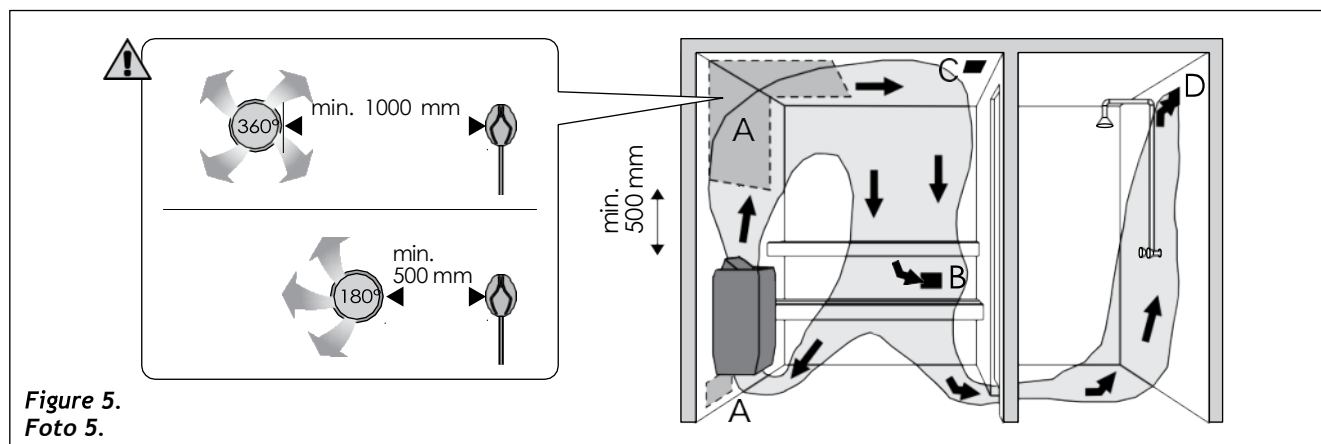

Figure 5.
Foto 5.

- A. Supply air vent location. If mechanical exhaust ventilation is used, place the supply air vent above the heater. If gravity exhaust ventilation is used, place the supply air vent below or next to the heater. The diameter of the supply air pipe must be 50–100 mm. **BC-E: Do not place the supply air vent so that the air flow cools the temperature sensor (see the temperature sensor installation instructions in the control unit installation instructions)!**
- B. Exhaust air vent. Place the exhaust air vent near the floor, as far away from the heater as possible. The diameter of the exhaust air pipe should be twice the diameter of the supply air pipe.
- C. Optional vent for drying (closed during heating and bathing). The sauna can also be dried by leaving the door open after bathing.
- D. If the exhaust air vent is in the washroom, the gap underneath the sauna door must be at least 100 mm. Mechanical exhaust ventilation is mandatory.

2.3. Heater output

When the walls and ceiling are covered with panels and insulation behind the panels is adequate, the heater output is defined according to the volume of the sauna. Non-insulated walls (brick, glass block, glass, concrete, tile, etc.) increase the need for heater output. Add 1,2 m³ to the volume of the sauna for each non-insulated wall square meter. For example, a 10 m³ sauna room with a glass door equals the output requirement of about a 12 m³ sauna room. If the sauna room has log walls, multiply the sauna's volume by 1,5. Choose the correct heater output from table 2.

2.4. Sauna Room Hygiene

Bench towels should be used during bathing to prevent sweat from getting onto the benches.

The benches, walls and floor of the sauna should be washed thoroughly at least every six months. Use a scrubbing brush and sauna detergent.

Wipe dust and dirt from the heater with a damp cloth. Remove lime stains from the heater using a 10% citric acid solution and rinse.

2.2. Prezračevanje savne

Zrak v savni je treba zamenjati šestkrat na uro. Slika 5 prikazuje različne možnosti prezračevanja savne.

- A. Oskrba z zrakom. V primeru mehanskega prezračevanja namestite dovod zraka nad pečjo. V primeru prezračevanja s pomočjo težnosti namestite dovod zraka pod pečjo ali ob njej. Premer cevi za dovod zraka mora biti 50-100 mm. BC-E: dovoda zraka ne nameščajte tako, da bi hladil temperaturno tipalo (za namestitev temperaturnega tipala glejte navodila za namestitev krmilne enote)!
- B. Prezračevanje. Odprtino postavite blizu tal, čim dlje od peči. Premer prezračevalne cevi naj bo dvakrat večji od premera cevi za dovod zraka.
- C. Opcijska odprtina za sušenje (zaprta med ogrevanjem in uporabo). Savno lahko sušite tudi skozi odprta vrata.
- D. Če je zračnik v umivalnici, mora biti razmik pod vrati savne vsaj 100 mm. Mehansko prezračevanje je obvezno.

2.3. Moč peči

Če sta stena in strop obložena in ustrezno izolirana, je moč peči odvisna od prostornine savne. Neizolirane stene (kamen, stekleni bloki, steklo, beton, ploščice) povečajo potrebno moč peči. Vsak kvadratni meter neizolirane stene pomeni 1,2 m³ več prostornine savne. Tako na primer 10 m³ kabina savne s steklenimi vrati po moči ustreza 12 m³ savne. Pri stenah z nosilci pomnožite prostornino savne z 1,5. Iz tabele 2 izberite ustrezno moč peči.

2.4. Čistoča in higiena v savni

Za zaščito klopi pred znojem uporabite brisače. Očistite klopi, stene in tla savne vsaj vsakih šest mesecev. Uporabljajte krtačo in čistilo za savno. Obrišite prah in umazanijo s peči z vlažno krpo. Obloge vodnega kamna na peči odstranite z 10 % citrsko kislino in sperite.

3. InStRUCtIoNS FoR InStALLAtIoN

3.1. Before Installation

Before installing the heater, study the instructions for installation. Check the following points:

- Is the output and type of the heater suitable for the sauna room? **the cubic volumes given in table 2 should be followed.**
- Is the supply voltage suitable for the heater?
- The location of the heater fulfils the minimum requirements concerning safety distances given in fig. 6 and table 2.

It is absolutely necessary to install the heater according to these values. neglecting them causes a risk of fire. only one electrical heater may be installed in the sauna room.

3. NAVODILA ZA NAMESTITEV

3.1. Pred montažo

Pred namestitvijo savne preberite navodila za namestitev in preverite naslednje stvari:

- Ali je peč za savno, ki bo vgrajena, primerna za kabino savne glede moči in tipa?
Vrednosti velikosti prostora iz preglednice 2 ne smejo biti presežene ali manjše.
- Ali je omrežna napetost primerna za savno?
- Mesto namestitve peči je v skladu z najmanjšimi varnostnimi razdaljami, navedenimi na sliki 6 in v preglednici 2

Te razdalje je treba strogo upoštevati, saj vsako odstopanje povzroči nevarnost požara. V savni je lahko nameščena samo en peč.

Heater Peč	Out-put Moč	Sauna room Savna			Electrical connections Električni priključki				
		Cubic vol. Volumen		Height Višina	400 V 3N~ Priključni kabel		Fuse Varovalka	230 V 1N~ Priključni kaber	
Model and dimensions/ Model in dimenzije		min. m ³	max. m ³	min. mm	mm ²	A	mm ²	A	mm ²
Width/širina • BC 480 mm • BC-E 450 mm Depth/globina 310 mm Height/višina 540 mm Weight/teža 11 kg Stones/kamni max. 20 kg		2.3.			See fig. 8. The measurements apply to the connecting cable only! Glej foto 8. Meritve se nanašajo izključno na priključni kabel!				
BC45/BC45E	4,5	3	6	1900	5 x 1,5	3 x 10	3 x 2,5	1 x 20	4 x 0,25
BC60/BC60E	6,0	5	8	1900	5 x 1,5	3 x 10	3 x 2,5	1 x 35	4 x 0,25
BC80/BC80E	8,0	7	12	1900	5 x 2,5	3 x 16	3 x 6	1 x 35	4 x 0,25
BC90/BC90E	9,0	8	14	1900	5 x 2,5	3 x 16	3 x 10	1 x 50	4 x 0,25

Table 2. Installation details

Tabela 2. Informacije o montaži

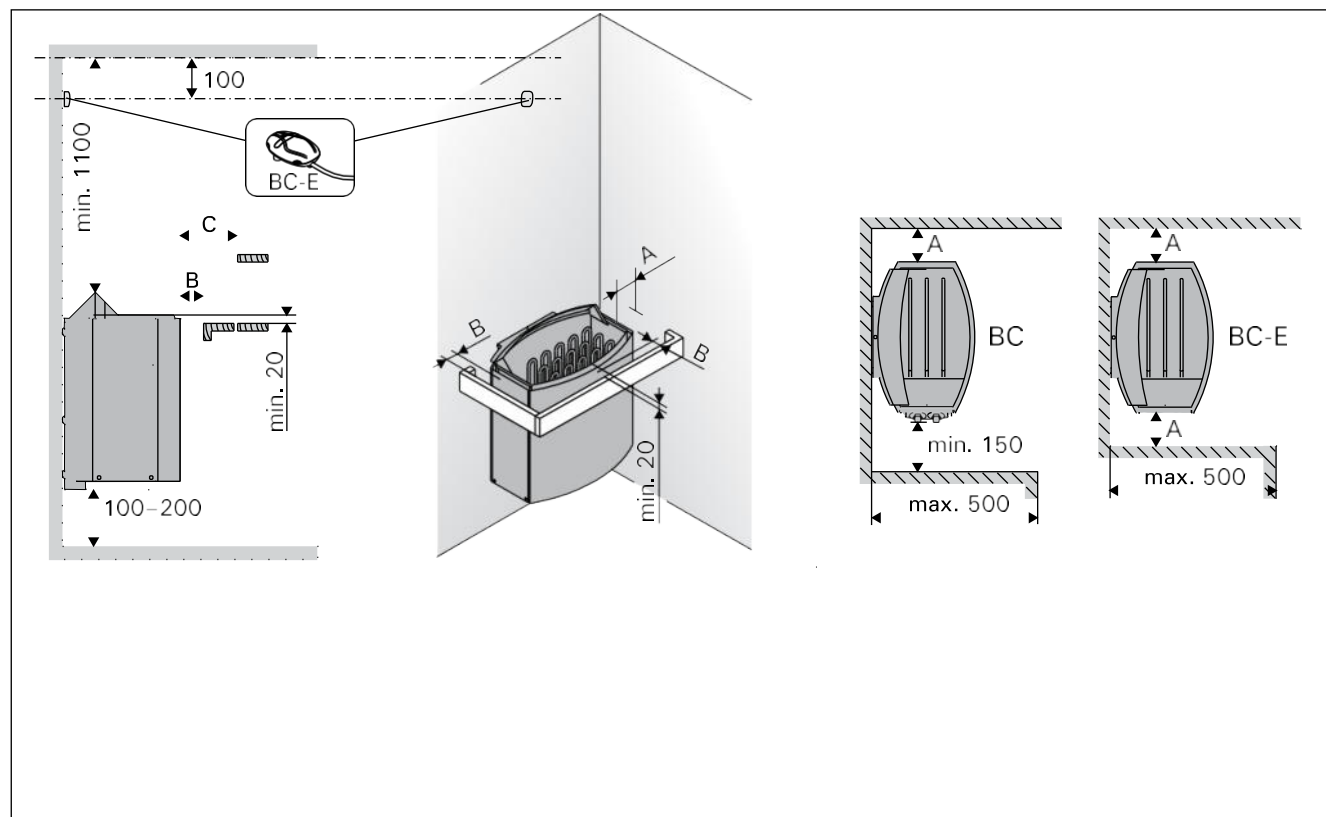

Figure 6. Safety distances (all dimensions in millimeters)

Foto 6. Najmanjše varnostne razdalje (vse mere v milimetrih)

3.2. Fastening the Heater on a Wall

See figure 7.

1. Remove both cardboard covers before installation.
2. Fasten the wall-mounting rack on the wall by using the screws which come with the rack. **notE! there must be a support, e.g. a board, behind the panel, so that the fastening screws can be screwed into a thicker wooden material than the panel. If there are no boards behind the panel, the boards can also be fastened on the panel.**
3. The right- or left-handedness of the heater can be changed by installing it to the rack correspondingly. Make sure the clip fastens in the hole properly.
4. Lift the heater to the rack on the wall so that the fastening hooks of the lower part of the rack go behind the edge of the heater body. Lock the edge of the heater onto the rack by a screw.

3.2. Pritrditev peči na steno

Glej foto 7.

1. Pred montažo odstranite oba zaščitna pokrovali!
2. Montažni okvir pritrdite na steno s priloženimi vijaki. **POZOR! Na mestih, kjer so pritrjeni pritrdilni vijaki, mora biti za ploščami material, ki služi kot opora, v katero se vijaki trdno zasidrajo. Če za ploščami ni desk, jih lahko namestite tudi pred plošče.**
3. Peč za savno je mogoče na steno namestiti različno za desničarje in levičarje. Prepričajte se, da so pritrdilne zanke pravilno nameščene na za to predvidenih točkah za obešanje..
4. Peč za savno dvignite na okvir na steni tako, da se pritrdilni kavli na dnu okvirja približajo robu ohišja peči za savno. Zgornji rob peči za savno privijte na okvir za pritrditev.

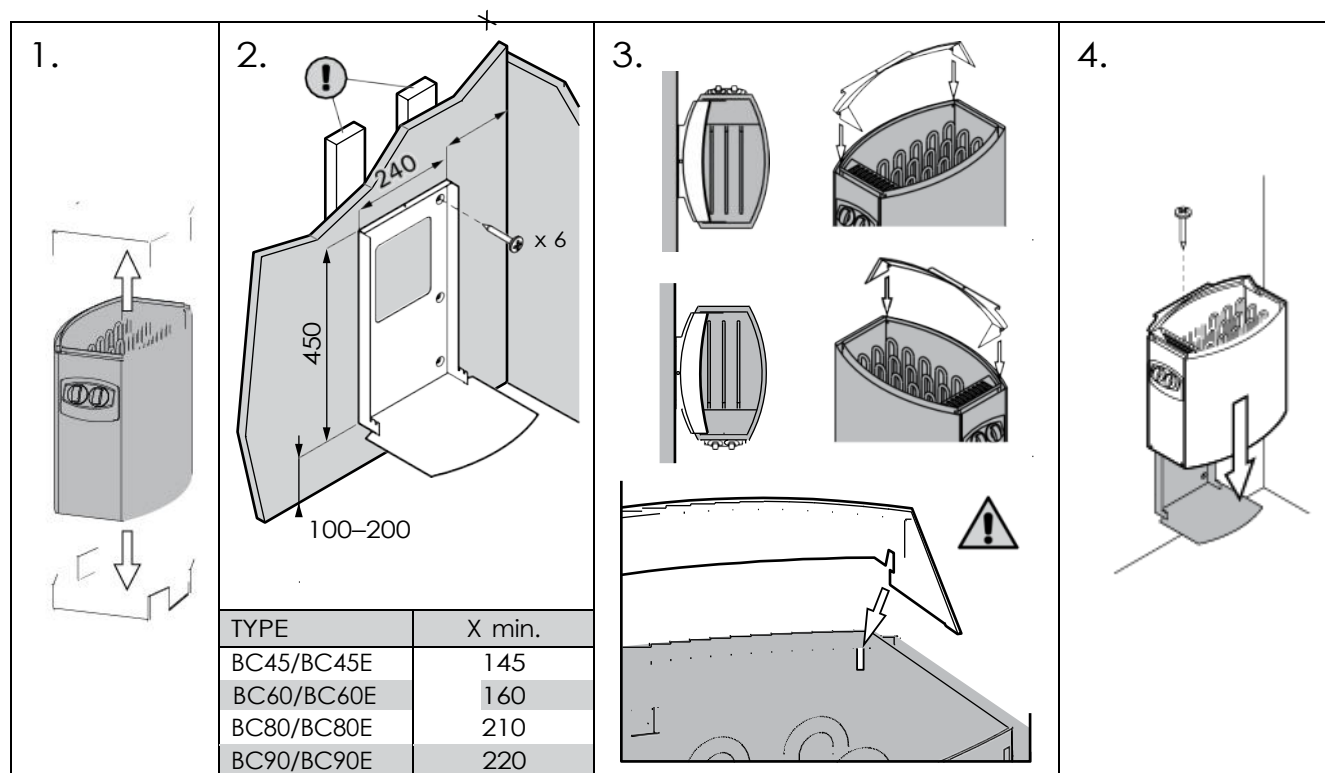

Figure 7. Fastening the heater on a wall (all dimensions in millimeters)
Foto 7. Pritrditev peči na steno (vse mere v milimetrih)

3.3. Electrical Connections

the heater may only be connected to the electrical network in accordance with the current regulations by an authorised, professional electrician.

- The heater is semi-stationarily connected to the junction box (figure 8: A) on the sauna wall. The junction box must be splash-proof, and its maximum height from the floor must not exceed 500 mm.
- The connecting cable (figure 8: B) must be of rubber cable type H07RN-F or its equivalent. **notE! Due to thermal embrittlement, the use of PVC-insulated wire as the connecting cable of the heater is forbidden.**
- If the connecting and installation cables are higher than 1000 mm from the floor in the sauna or inside the sauna room walls, they must be able to endure a minimum temperature of 170 °C when loaded (for example, SSJ). Electrical equipment installed higher than 1000 mm from the sauna floor must be approved for use in a temperature of 125 °C (marking T125).
- In addition to supply connectors, the BC heaters are equipped with a connector (P), which makes the control of the electric heating possible (figure 10). Voltage control is transmitted from the heater when it is switched on. The control cable for electrical heating is brought directly into the junction box of the heater, and from there to the terminal block of the heater along a rubber cable with the same cross-section area as that of the connecting cable.
- **When closing the cover of the connection box make sure that the upper edge of the cover is placed correctly.** If the upper edge is misplaced water can enter the connection box. Figure 8.

3.3. Električni priključki:

Peč savne lahko na električno omrežje priključi le pooblaščen električar v skladu z veljavnimi predpisi.

- Peč za savno je delno trajno pritrjena na priključno omarico (slika 8: A) na steni savne. Priključna omarica mora biti zaščiten pred brizganjem vode in ne sme biti nameščena več kot 500 mm nad tlemi.
- Kot priključni kabel se uporablja gumijasti kabel tipa H07RN-F ali ustrezen kabel (slika 8: B). **Kablov s PVC-izolacijo zaradi njihove slabe toplotne odpornosti ne smete uporabljati kot priključnih kablov za savna peč.** Če priključni ali inštalacijski kabli vstopajo v savno ali stene savne na višini več kot 1000 mm nad tlemi, morajo pri obremenitvi zdržati temperaturo najmanj 170 °C (npr. SSJ). Električne naprave, ki so nameščene višje kot 1000 mm od tal savne, morajo biti odobrene za uporabo pri temperaturi okolja 125 °C (opomba T125).
- Poleg omrežnega priključka so peči za savne BC opremljene s priključkom (P), ki omogoča upravljanje električnega ogrevanja (slika 9). Peč ob vklopu prevzame nadzor nad napetostjo. Krmilni kabel za električno ogrevanje je napeljan neposredno do priključne omarice peči savne, od tam pa je preko gumijastega kabla enake debeline speljan do priključne omarice peči savne.
- **Ko zapirate pokrov polnilne škatle, se prepričajte, da se pokrov popolnoma zapre. Če pokrov ni pravilno nameščen, lahko voda steče v priključno škatlo.** Foto 8.

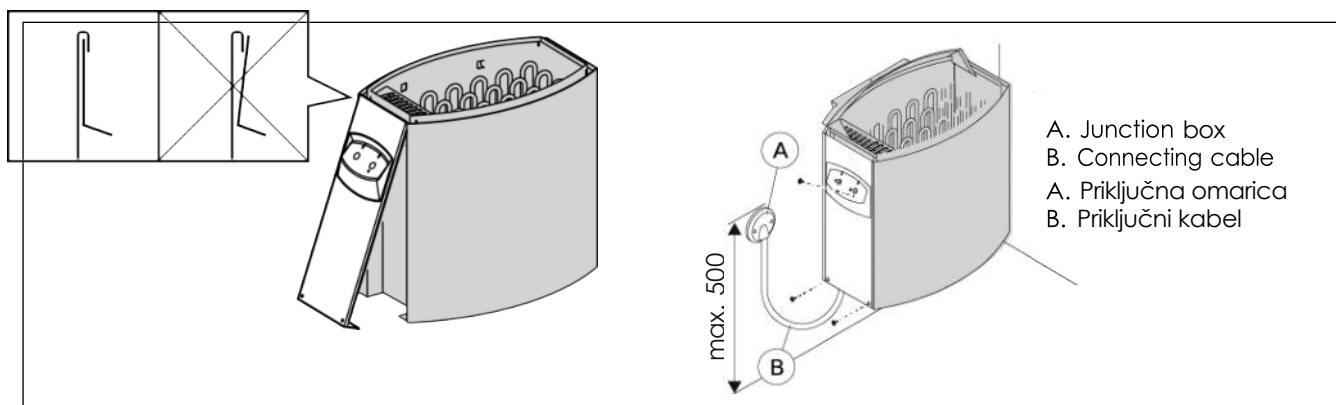

Figure 8. Closing the cover of the connection box (all dimensions in millimeters)
Foto 8. Zapiranje priključne omarice (vse mere v milimetrih)

3.3.1. Electric Heater Insulation Resistance

When performing the final inspection of the electrical installations, a "leakage" may be detected when measuring the heater's insulation resistance. The reason for this is that the insulating material of the heating elements has absorbed moisture from the air (storage, transport). After operating the heater for a few times, the moisture will be removed from the heating elements.

Do not connect the power feed for the heater through the RCD (residual current device)!

3.3.1. Izolacijska odpornost električne peči za savno

Med končnim pregledom električnih inštalacij lahko pri merjenju izolacijske upornosti pride do "puščanja", ki je posledica vstopa vlage iz zraka v izolacijski material grelnih uporov (med skladiščenjem in prevozom). Vlaga iz upora izstopi po dveh segrevanjih.

Ne vklaplajte električnega toka električne savne prek odklopnika preostalega toka!

3.4. Installation of the Control Unit and Sensors (BC-E)

The control unit includes detailed instructions for fastening the unit on the wall. Install the temperature sensor on the wall of the sauna room above the heater. It should be installed on the lateral centre line of the heater, 100 mm downwards from the ceiling. Figure 6.

Do not place the supply air vent so that the air flow cools the temperature sensor. Figure 5.

3.5. Resetting the overheat Protector

If the temperature of the sauna room becomes dangerously high, the overheat protector will permanently cut off the supply of the heater. The overheat protector can be reset after the heater has cooled down.

BC

The reset button is located inside the heater's connection box (figure 9). **only persons authorised to carry out electrical installations can reset the overheat protector.**

Prior to pressing the button, the cause of the fault must be found.

- Are the stones crumbled and pressed together?
- Has the heater been on for a long time while unused?
- Is the sensor of the thermostat out of place or broken?
- Has the heater been banged or shaken?

BC-E

See the installation instructions for control unit.

3.4. Priključitev krmilne enote in senzorjev (BC-E)

V zvezi z upravljalno enoto so podana natančna navodila, kako jo pritrditi na steno. Temperaturno tipalo je nameščeno na steno savne nad savno, 100 mm pod stropom na osi v smeri širine savne.. Foto 6.

Naprave za dovod zraka ne postavljajte tako, da bi hladila temperaturno tipalo. Foto 5.

3.5. Ponastavitev zaščite pred pregrevanjem

Če temperatura v kabini savne nevarno naraste, zaščita pred pregrevanjem trajno prekine napajanje peči. Zaščito pred pregrevanjem lahko ponastavite, ko se peč ohladi.

BC

Gumb za ponastavitev se nahaja v priključnem ohišju peči (foto 9). To delo lahko opravi le oseba, ki je pooblaščen za izvajanje električnih inštalacij.

Pred pritiskom na gumb je treba ugotoviti vzrok okvare:

- Če so kamni v savni zataknjeni ali krhki?
- Ali je bila peč savne vklopljena dlje časa in se ni uporabljal?
- Če je tipalo termostata na napačnem mestu ali v okvari?
- Ali je bila peč savne izpostavljen močnim udarcem?

BC-E

Glejte navodila za uporabo in namestitvev krmilne enote.

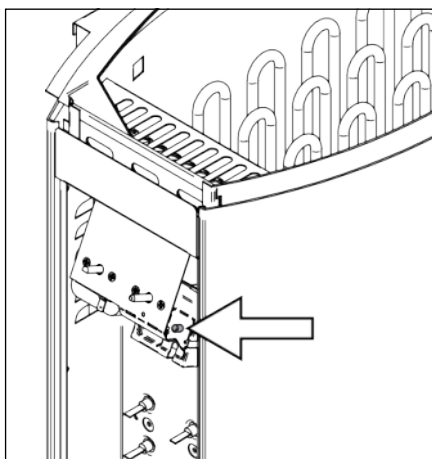

Figure 9.
Foto 9.

Reset button for overheat protector
Gumb za ponastavitev zaščite pred pregrevanjem

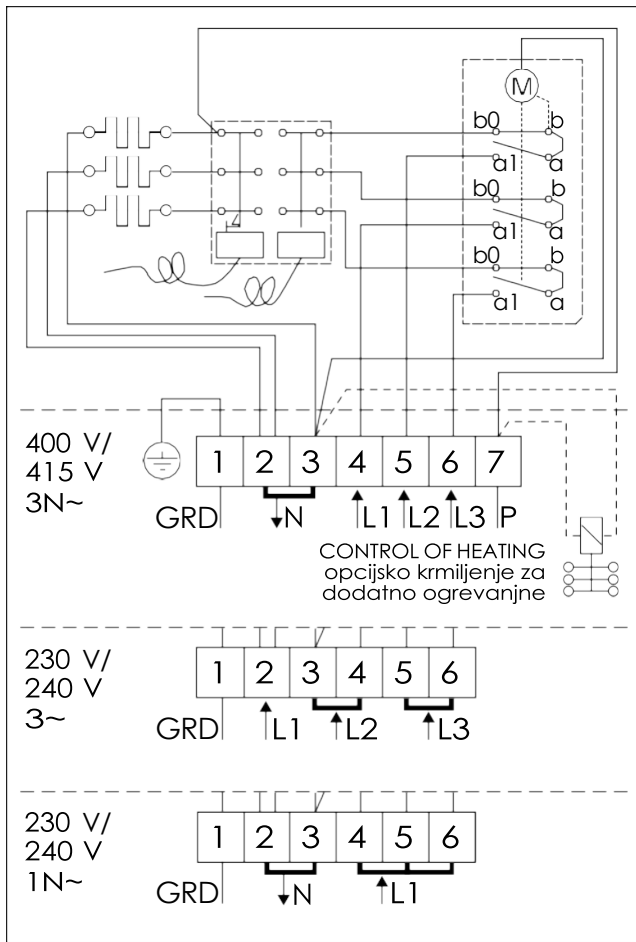

Figure 10. Electrical connections of BC heater
Foto 10. Elektro priključki peči BC

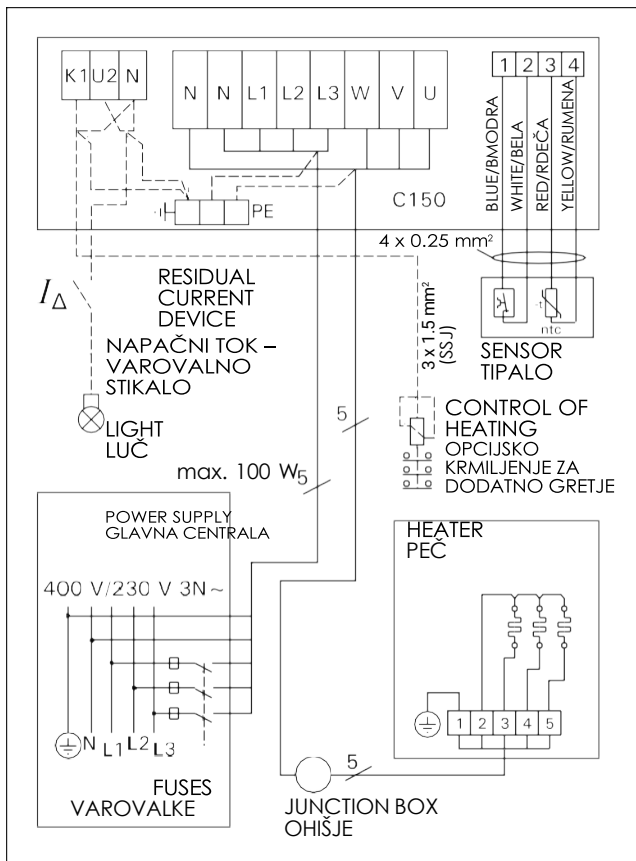

Figure 12a. 3-phase electrical connections of control unit C150 and BC-E heater
Foto 12a. 3-električni priključki Krmilna enota C150 in peč BC-E

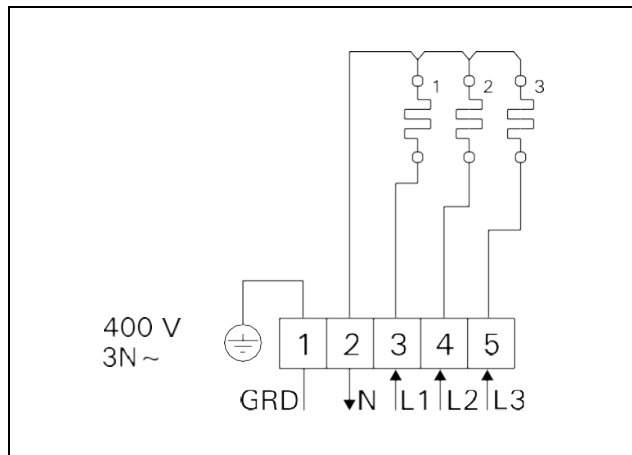

Figure 11. Electrical connections of BC-E heater
Foto 11. Elektro priključki peči BC-E

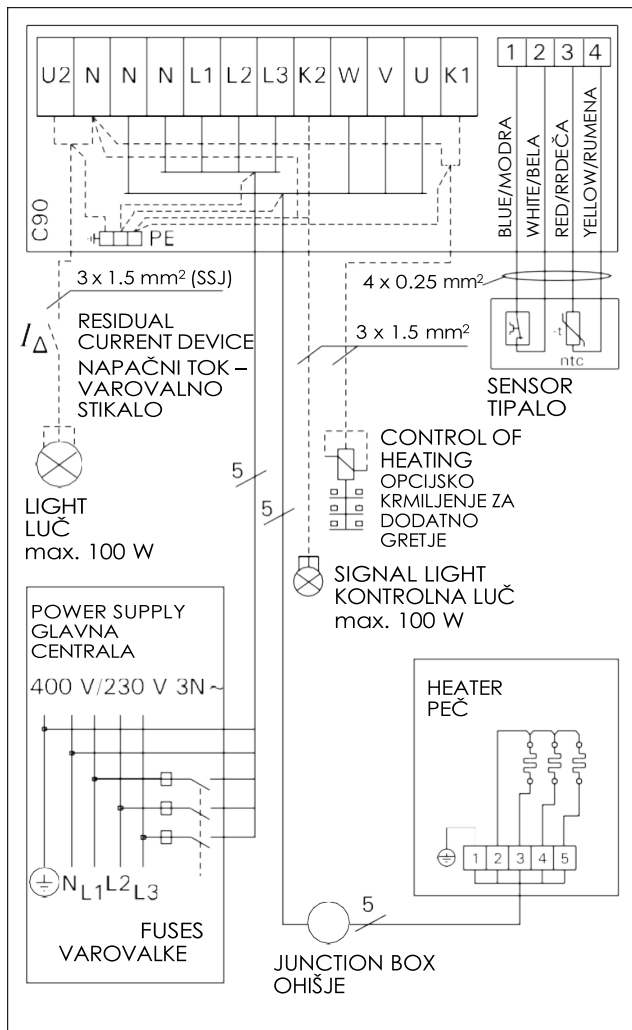
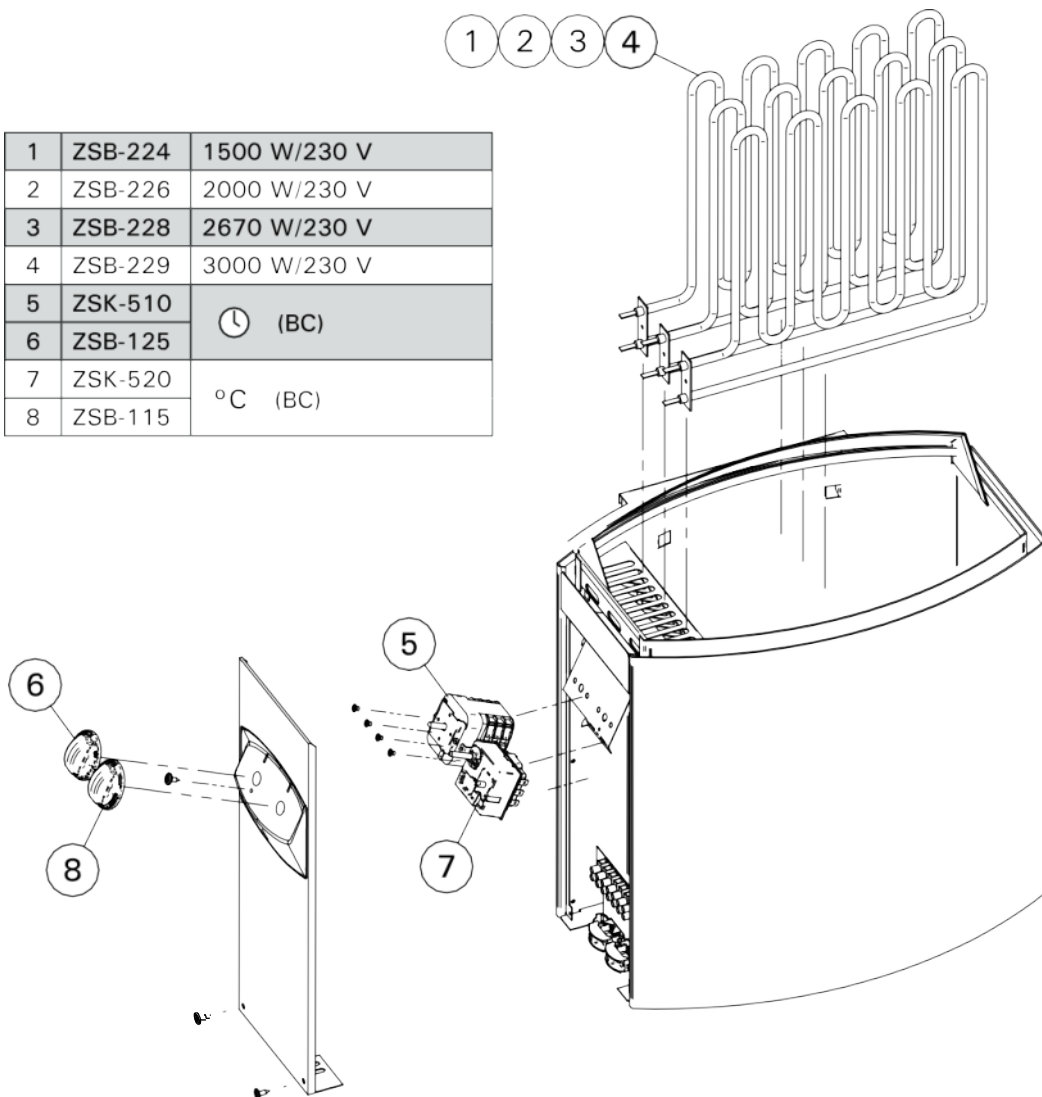

Figure 12b. 3-phase electrical connections of control unit C90 and BC-E heater
Foto 12b. 3-fazni električni priključki Krmilna enota C90 in peč BC-E

4. SPARE PARTS

4. REZERVNI DELI

1	ZSB-224	1500 W/230 V
2	ZSB-226	2000 W/230 V
3	ZSB-228	2670 W/230 V
4	ZSB-229	3000 W/230 V
5	ZSK-510	⌚ (BC)
6	ZSB-125	
7	ZSK-520	°C (BC)
8	ZSB-115	



HARVIA

Harvia Oy
PL12
40951 Muurame
Finland
www.harvia.fi

Upute za montažu

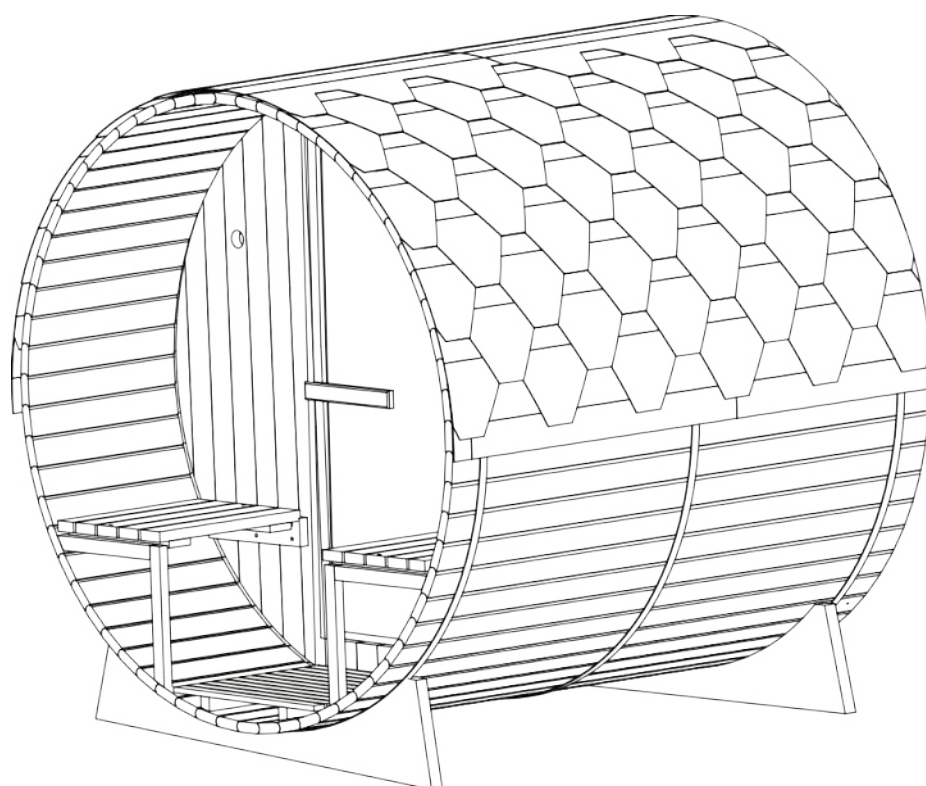

— Infracrveno svjetlo omogućuje zdraviji život —

Zbog stalnog poboljšanja proizvoda, proizvod prikazan u ovim uputama za uporabu može se malo razlikovati od stvarnog proizvoda.

Preporuke

Pažljivo pročitajte ove upute prije prve uporabe saune.

Preporučujemo da ih čuvate na sigurnom mjestu kako bi uvijek bili dostupni.

- Drvo je živi element. Kako bi očuvalo izvorni izgled, drvo je potrebno zaštititi od vlage izvana.
- Postavite saunu na potpuno ravnu i tvrdu podlogu.
- Sauna mora biti postavljena na suho mjesto. Nemojte ju koristiti u blizini izvora vode (kade, mokar pod, bazen).
- Ne koristite tekuća agresivna sredstva za čišćenje. Prije čišćenja isključite saunu i koristite samo vlažnu krpu.
- Zaštitite električni kabel saune od gnječenja ili prignječenja.
- Prije zamjene određenih komponenti provjerite jesu li navedene od strane proizvođača ili imaju li iste karakteristike kao originalni dijelovi. Nepravilna zamjena može uzrokovati požar, kratki spoj ili oštećenje saune. Preporučujemo da se obratite kvalificiranom tehničaru.
- Kako biste izbjegli rizik od opekline ili strujnog udara, nemojte koristiti metalne alate.
- Nije dopušteno dovoditi životinje u saunu.
- Ne ostavljajte saunu uključenu bez nadzora.
- Ne ostavljajte saunu uključenu dulje od 3 sata kako biste izbjegli prerano oštećenje uređaja. Nakon 3 sata neprekidnog rada isključite saunu najmanje jedan sat.
- Ne preporučuje se ugradnja sustava zaključavanja na vrata saune.
- Prije spajanja saune na električnu mrežu, provjerite ispunjava li vaša električna instalacija zahtjeve.

Sigurnosne informacije

VAŽNO:

Pažljivo pročitajte sigurnosne upute prije postavljanja i korištenja saune. Oni su ključni za vašu sigurnost, pa ih se pažljivo pridržavajte.

Čuvajte se hipertemije, toplinskog udara ili toplinske iscrpljenosti, koji mogu biti uzrokovani ili pogoršani ako se ne slijede sigurnosne upute. Simptomi uključuju vrućicu, ubrzan puls, vrtoglavicu, nesvjesticu, letargiju i obamrlost cijelog tijela ili njegovih dijelova. Posljedice su: smanjena percepcija topline, nesvjesnost nadolazeće opasnosti, nesvjestica.

Saunu ne smiju koristiti:

- djeca mlađa od 6 godina
- osobe s teškim reakcijama na sunčevu svjetlost
- starije osobe ili osobe s invaliditetom
- osobe s već postojećim stanjima kao što su bolesti srca, visoki ili niski krvni tlak, problemi s cirkulacijom krvi ili dijabetes, bez prethodnog liječničkog savjeta
- trudne žene, previsoka temperatura može ugroziti plod
- osobe s dehidracijom, otvorenim ranama, očnim bolestima, opeklinama ili sunčanim udarom.

Djeca od 6 do 16 godina mogu koristiti saunu ako su stalno pod nadzorom odgovorne odrasle osobe i ako temperatura u sauni ne prelazi 60 °C.

Ako imate zdravstvenih problema, uzimate lijekove ili imate oštećene mišiće ili ligamente, saunu možete koristiti samo uz prethodnu konzultaciju i odobrenje liječnika.

Ako nosite kirurške implantate, nemojte koristiti saunu bez prethodnog savjetovanja i pristanka svog liječnika. Nemojte koristiti saunu nakon naporne aktivnosti.

Pričekajte 30 minuta da vam se tijelo ohladi.

Ne provodite više od 40 minuta u sauni odjednom.

Ne konzumirajte alkohol ili droge prije ili tijekom saune.

Nemojte spavati u sauni koja radi.

Kako biste izbjegli rizik od pregrijavanja, spojite saunu na dovoljno jaku utičnicu i nemojte spajati druge električne uređaje na istu utičnicu.

Kako biste izbjegli opasnost od strujnog udara ili oštećenja saune, nemojte je koristiti:

- za vrijeme oluje
- ako je električni kabel oštećen, mora ga zamijeniti kvalificirana osoba
- ako se električni kabel pregrije, mora ga provjeriti kvalificirana osoba
- ako trebate promijeniti žarulju, pričekajte da se sauna isključi i ohladi.

Osušite ruke prije spajanja ili isključivanja napajanja. Nikada ne radite s mokrim rukama ili nogama.

Nemojte brzo uključivati ili isključivati sustav napajanja ili grijanja jer to može uzrokovati oštećenje električnog sustava. Ne pokušavajte sami popraviti saunu bez pristanka prodavača ili proizvođača.

Neovlašteni pokušaji popravka poništiti će jamstvo proizvođača.

Ne koristite nikakva sredstva za čišćenje u sauni.







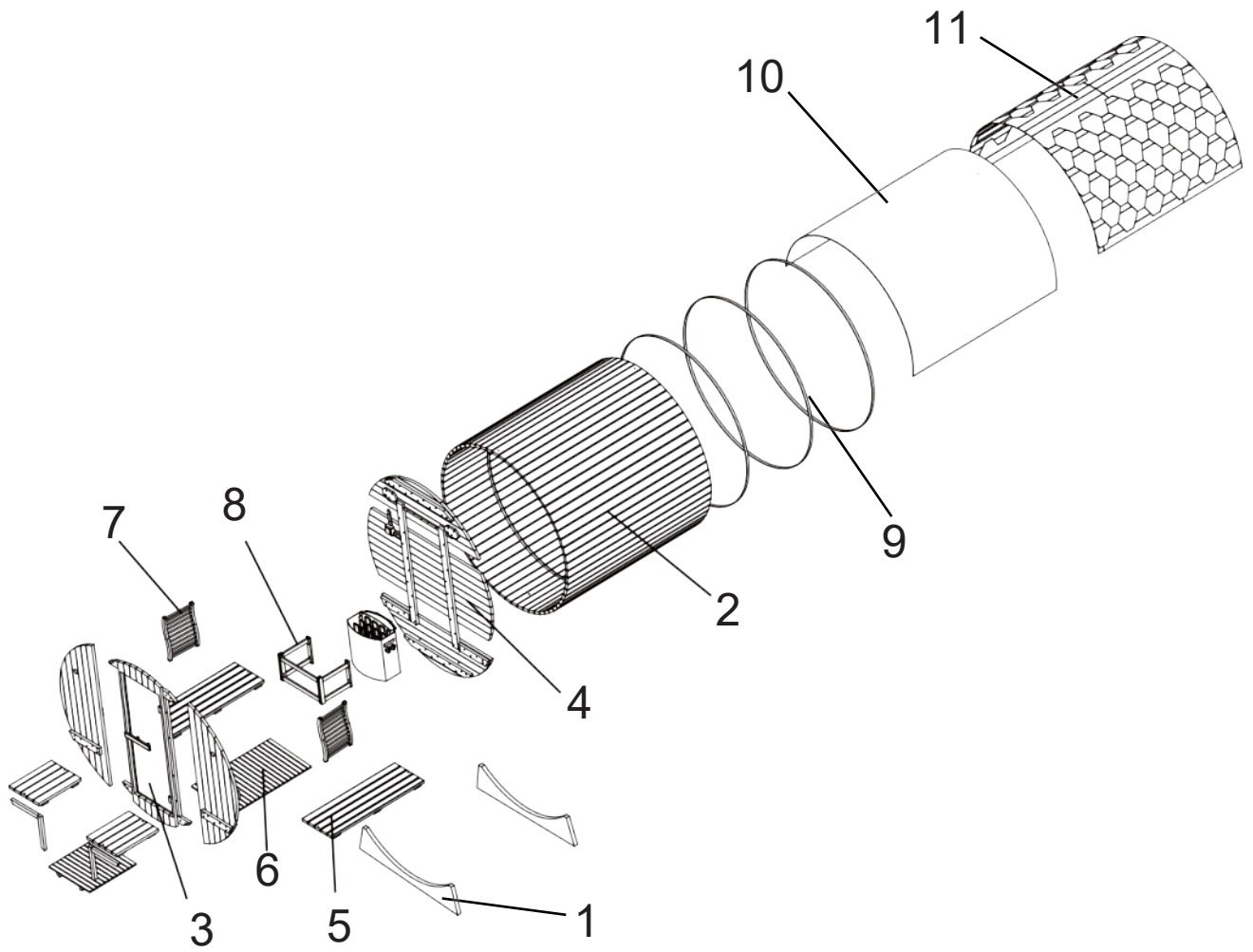



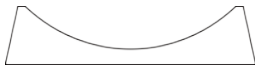

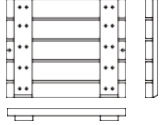

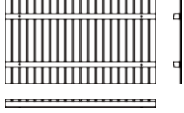
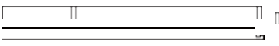
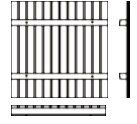
Nemojte slagati niti spremati nikakve predmete u ili na saunu.

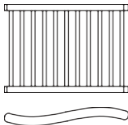
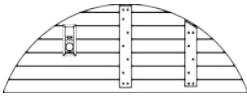
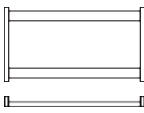
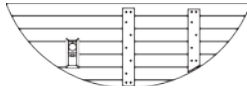
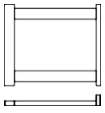
Ne stavlajte zapaljive materijale ili kemijske tvari blizu saune.

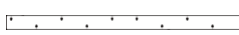

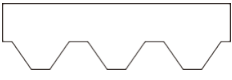

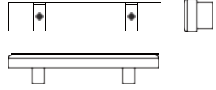
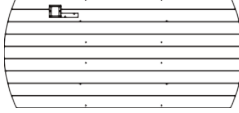
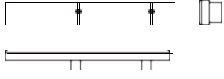

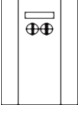
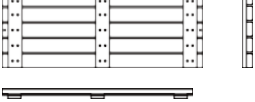
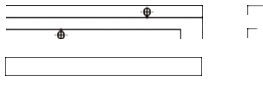
Opis saune



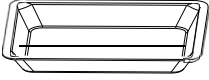

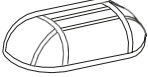
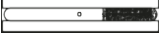

Opis saune

1		(1400x300x33mm) 2x	5.2		(426x398x30mm) 2x
2.1		(1800x93x30mm) 2x	5.3		(532x425x50mm) 2x
2.2		(1800x93x30mm) 1x	6.1		(990x585x40mm) 1x
2.3		(1800x93x30mm) 60x	6.2		(535x585x40mm) 1x
2.4		(1800x93x30mm) 1x	7		(520x330x65mm) 2x
3.1		(1758x575x30mm) 1x	8.1		(560x300x40mm) 1x
3.2		(1650x575x30mm) 1x	8.2		(378x300x40mm) 2x
3.3		(1758x952x30mm) 1x	9		3x obruč za bačvu
4.1		(1404x80x20mm) 1x	10		(3000x1800mm) 1x
4.2		(1404x80x20mm) 1x	11		(1000x320mm) 60x
4.3		(1574x488x30mm) 1x	12		(250x50x45mm) 1x
4.4		(1758x783x30mm) 1x	13		(350x50x45mm) 1x
4.5		(1574x488x30mm) 1x	14		1x peč za saunu
5.1		(1152x425x50mm) 2x	15		(177x80x30mm) 1x

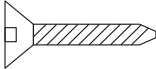
Opis saune

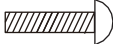
16		1x posuda za vodu	20		1x higrometar
17		2x poklopac svjetla	21		1x pješčani sat
18		2x držač šalice	22		1x kutlača
19		1x vjedro			

							
Ø5x50	Ø4x50	Ø4x30	Ø3x35	Ø4x12	Ø6x70		
44x	20x	8x	66x	240x	2x	2x	

Prije početka pažljivo pročitajte upute za instalaciju.

Odabir lokacije – dizajnirana isključivo za postavljanje na otvorenom

Odaberite mjesto:

- U suhoj prostoriji, na ravnoj, stabilnoj površini koja može izdržati težinu saune.
- Visina mora biti takva da možete dosegnuti strop i izvesti električne spojeve i radove održavanja.
- Ne u blizini izvora vode, plamena ili zapaljivih materijala.

Praktične savjete:

- Imajte na umu da su za sastavljanje saune potrebne 3 odrasle osobe.
- Prije nego počnete, jasno označite svaku ploču.
- Prilikom sastavljanja provedite strujni kabel saune tako da bude lako dostupan.
- Imajte na umu da postoje razlike između pojedinih modela.

VAŽNO :

Kako biste izbjegli oštećenje drva, provjerite dubinu i promjer rupa za bušenje.

Potreban alat



izvijač



metar



olovka



oštrica



2 ključ

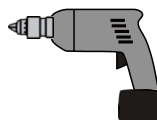

električni odvijač



svrdlo za drvo



šesterokutni ključ



ljestve

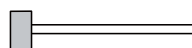

čekić

Upute za montažu

 Ø 5 x 50 20 kom

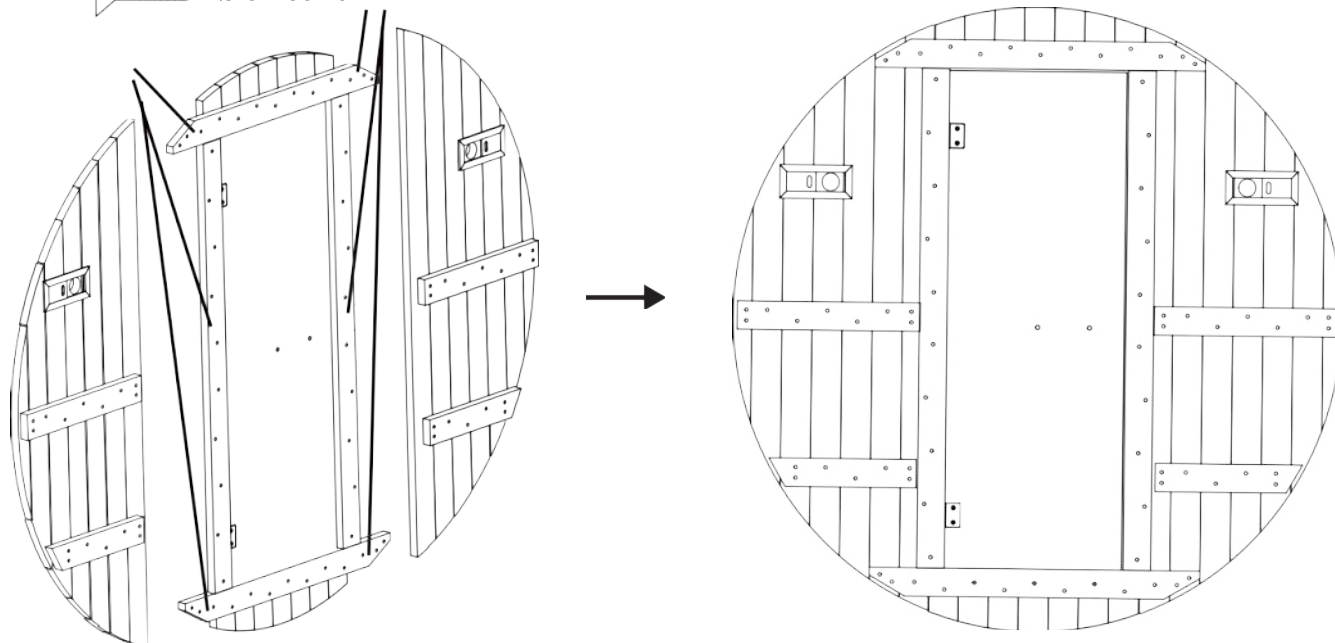

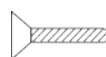
 Ø 3 x 35 2 kom

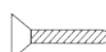
 Ø 5 x 50 18 kom

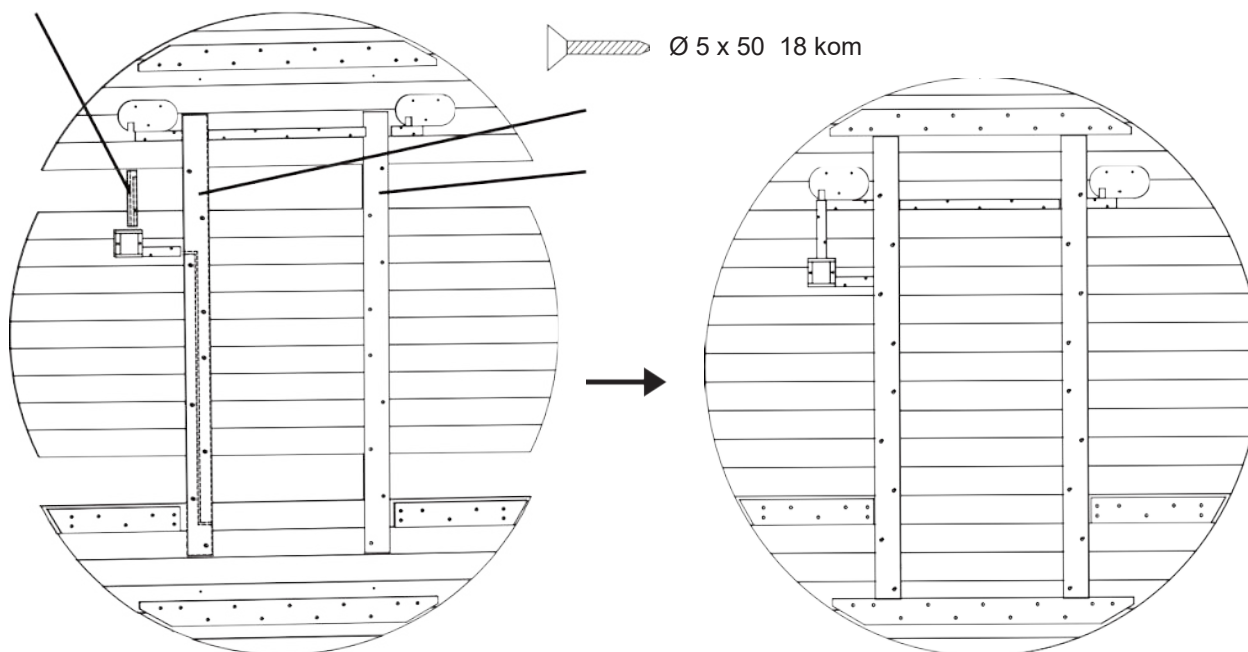

Prednju i stražnju ploču prvo morate sastaviti u cjelinu.

Prednja ploča je podijeljena na tri dijela s lijeve i desne strane, a stražnja ploča je podijeljena na tri dijela s gornje i donje strane.

Upute za montažu

Koraci montaže

 Ø 5 x 50 2 kom

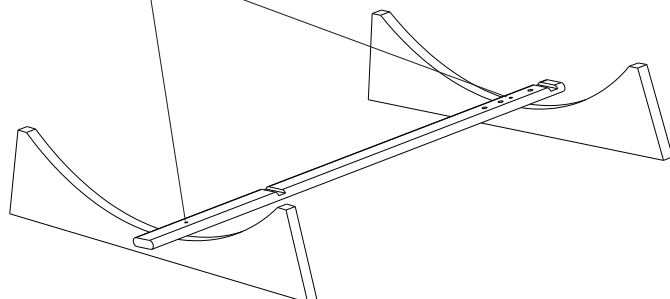

donji oslonac

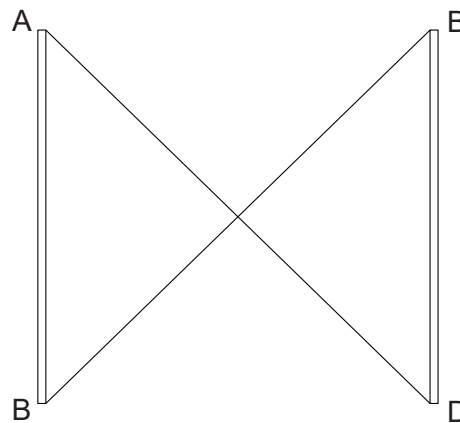

AD=BC AB=BD

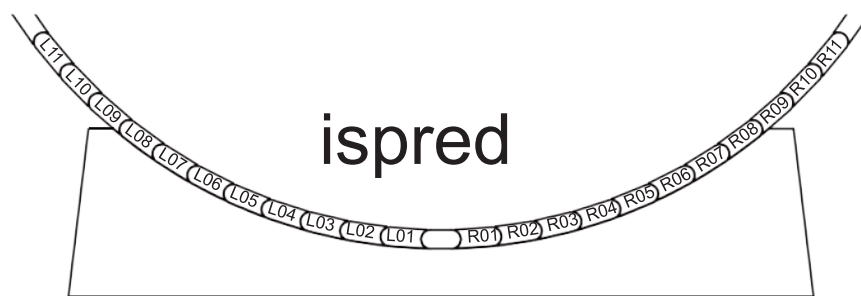

Svaka letvica je numerirana i označena.

Lijeva strana je označena L01 L02 L03..... L38 odozdo prema gore;

Desna strana je označena R01 R02 R03..... R38 odozdo prema gore.

Upute za montažu

Koraci montaže

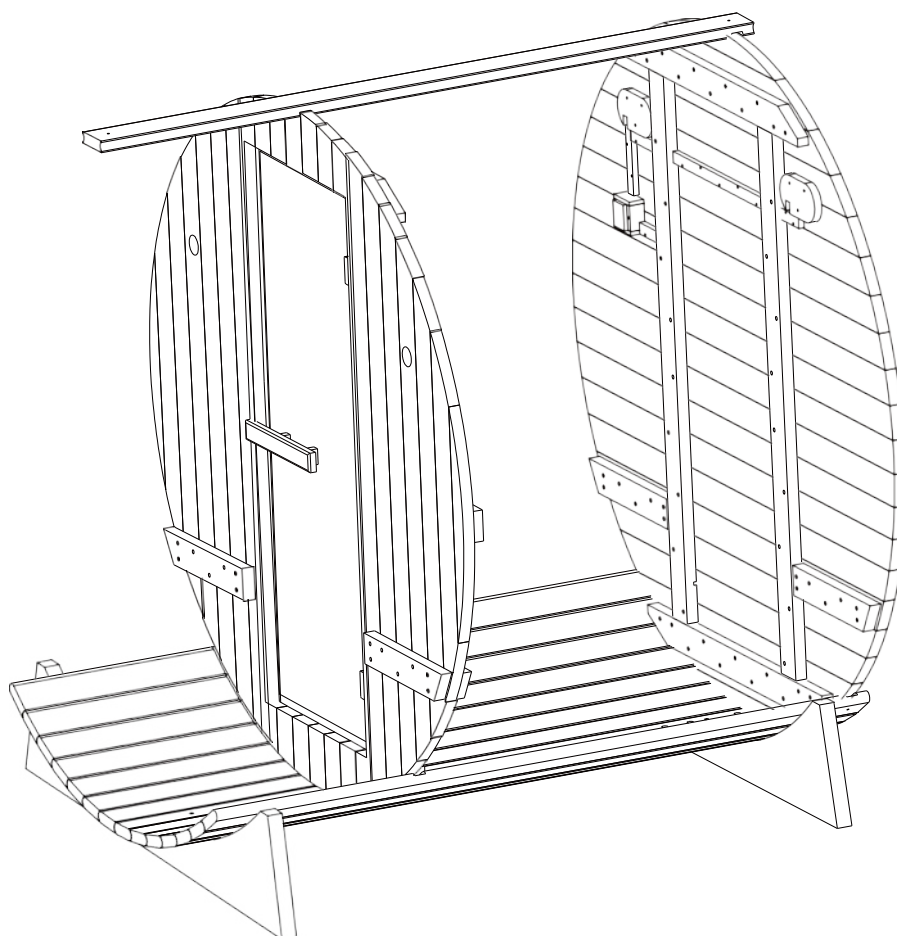
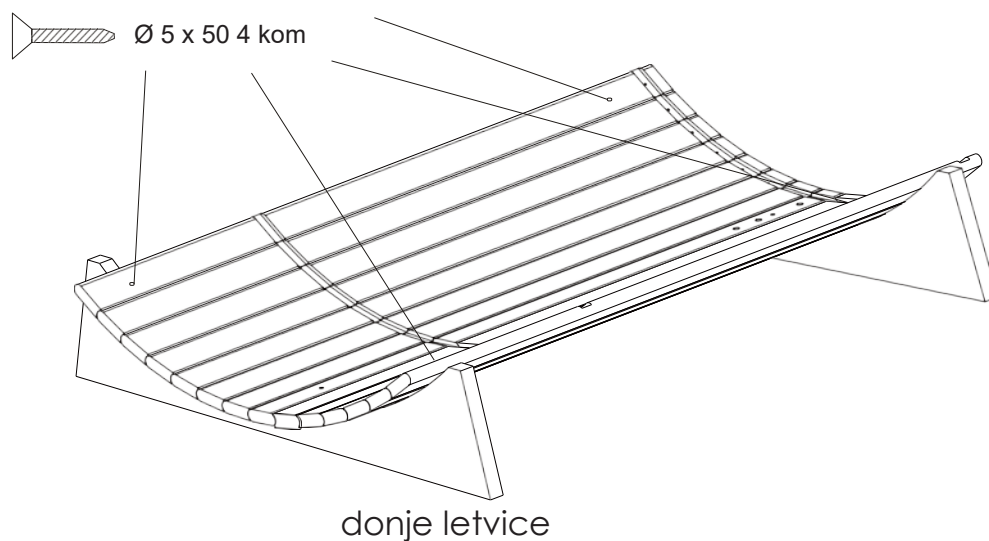

Privremeno postavite gornju letvu kao zaštitnu mjeru tijekom montaže.

Upute za montažu

Koraci montaže

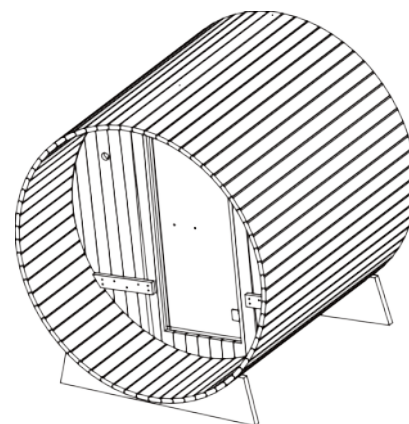
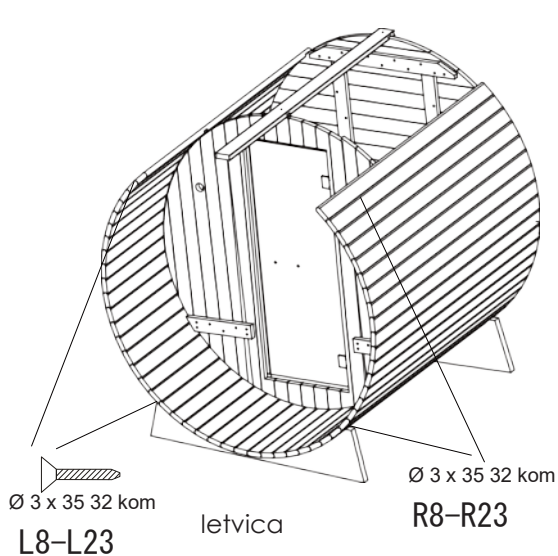

1. Donje letvice kućišta bačve trebaju biti čvrsto pričvršćene, to će olakšati montažu gornjeg dijela i pomoći pri stezanju.
2. Vijci (M3*35, 64 kom) koriste se za ugradnju letvica L8-L23 i R8-R23, gornje letvice se čvrsto postavljaju, nakon što se formira cijeli cilindar, tijelo bačve se fiksira trakama od nehrđajućeg čelika.

Prema stvarnim potrebama instalacije, možete otpustiti vijke i ukloniti jednu ili dvije tanke ploče u sredini.

tanke ploče

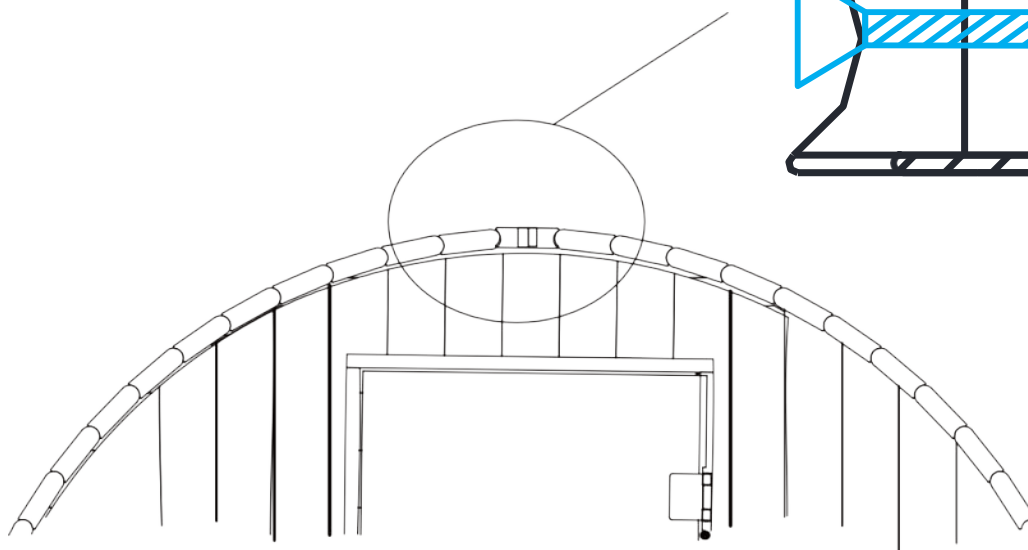
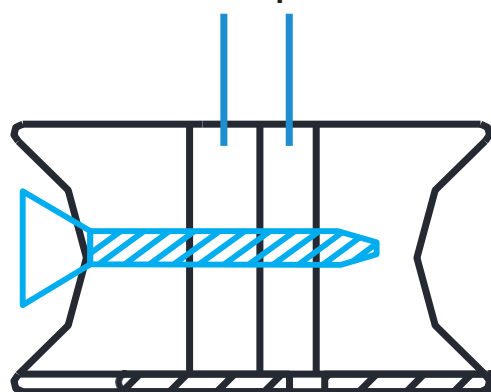

Upute za montažu

Koraci montaže

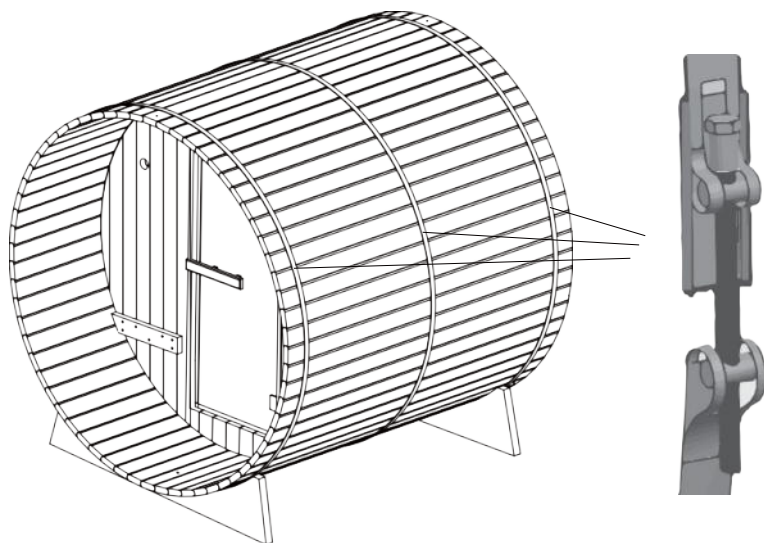

trake od nehrđajućega čelika

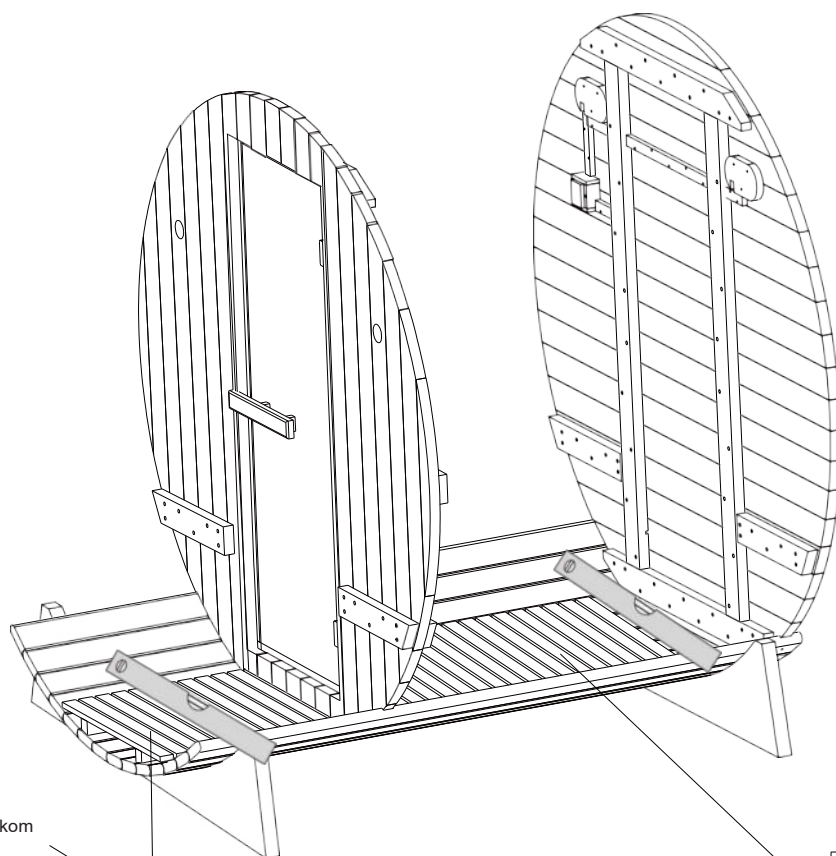

Ø 4 x 50 4 kom

Ø 4 x 50 4 kom

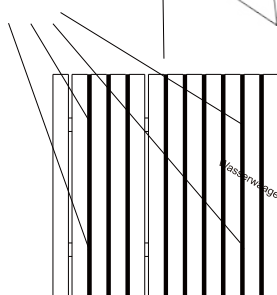

Wasserwaage

oslonac za noge

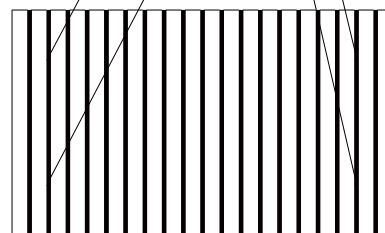

Upute za montažu

Koraci montaže

Nosač unutarnje i vanjske ploče sjedala unaprijed su instalirani na prednjoj i stražnjoj ploči.

Za vanjsku ploču sjedala potrebna je dodatna potpora koja se ugrađuje vijcima na donju ploču.

Unutarnja ploča sjedala ne treba dodatnu potporu.

Vijci za zaključavanje ploča sjedala moraju biti pričvršćeni na nosače na prednjim i stražnjim pločama.

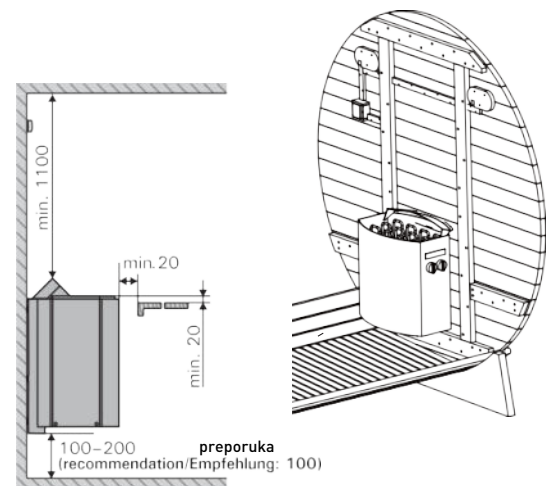
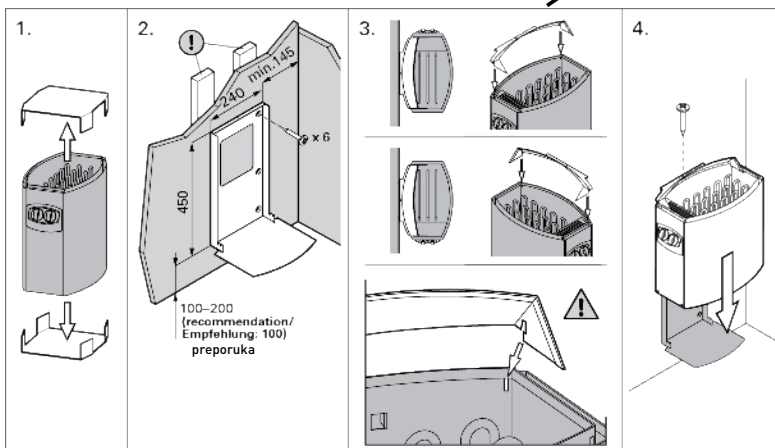
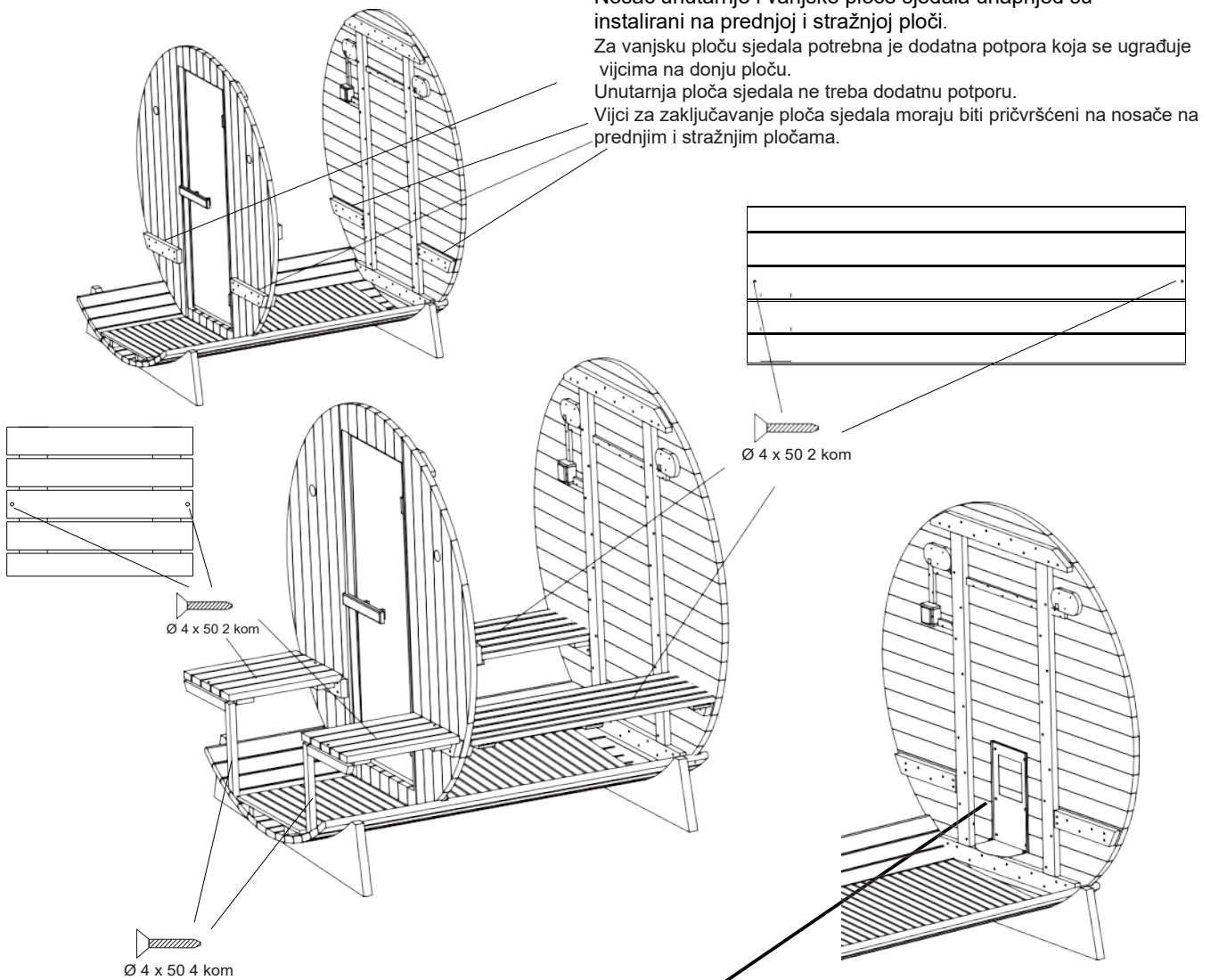

Montaža saune zahtijeva da prvo postavite zidni nosač okvira peći, a zatim objesite peć. Pogledajte shemu za specifične informacije.

Za detaljnije informacije pročitajte priručnik koji dolazi uz peć za saunu.

peć za saunu opremljena je univerzalnim kablom koji se spaja na vanjski izvor napajanja.
Električni kablovi svjetiljki moraju biti spojeni i napajani kroz ožičenje peći za saunu.

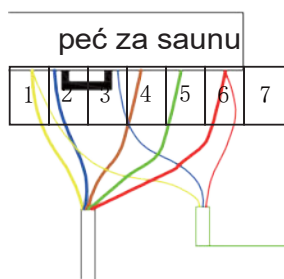
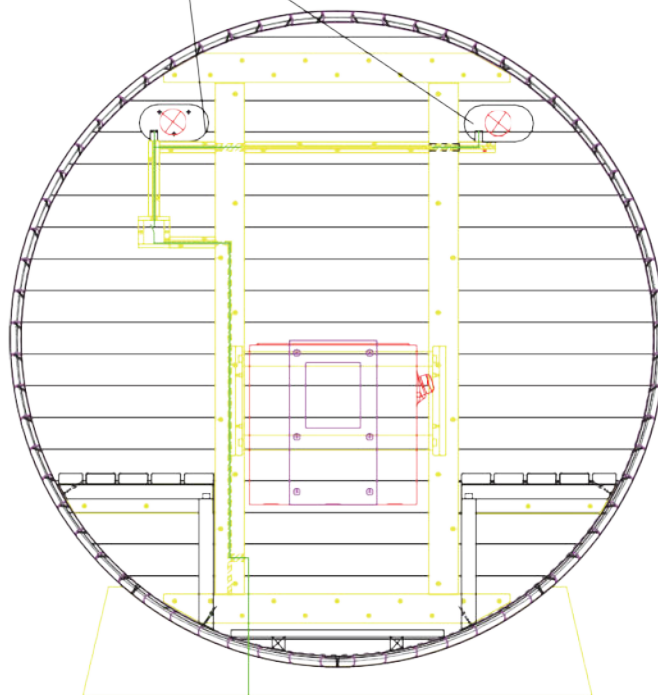
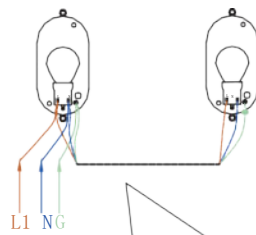

Kabel za
peć (5*2.5mm²)

kabel za svjetlo (3*0.75mm²)

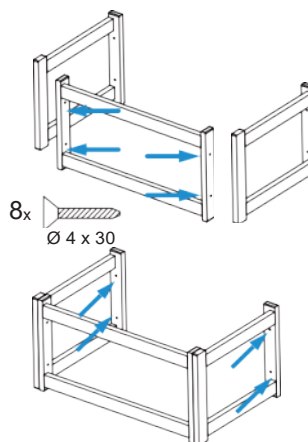
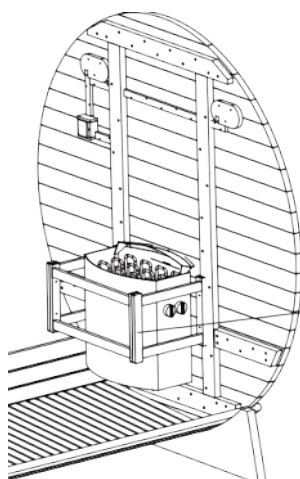

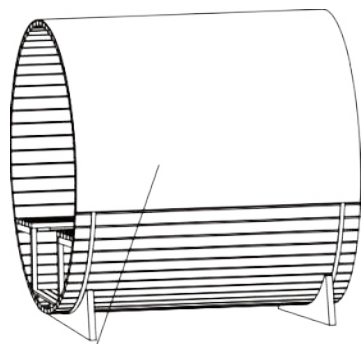

vodootporna tkanina

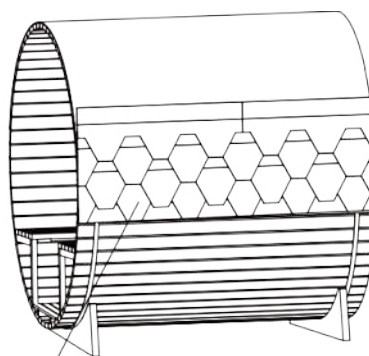

bitumenske šindre

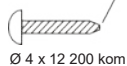

Ø 4 x 12 200 kom

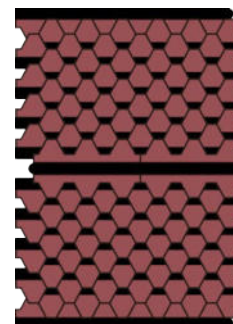
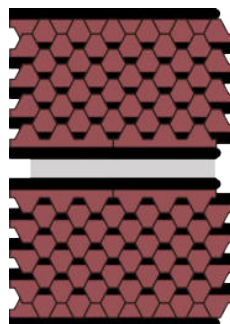
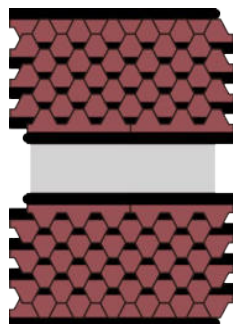
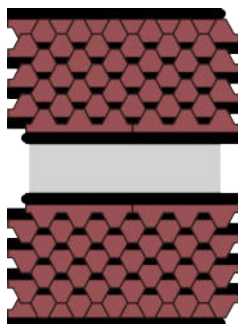
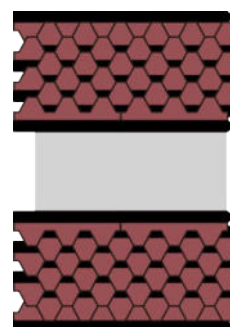
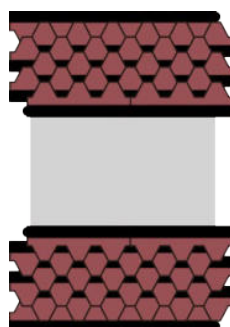
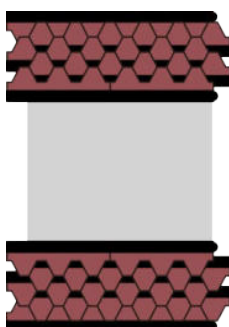
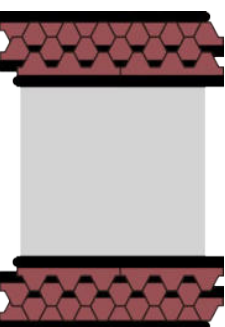
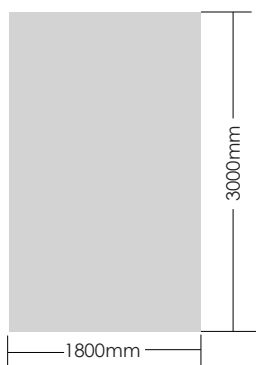

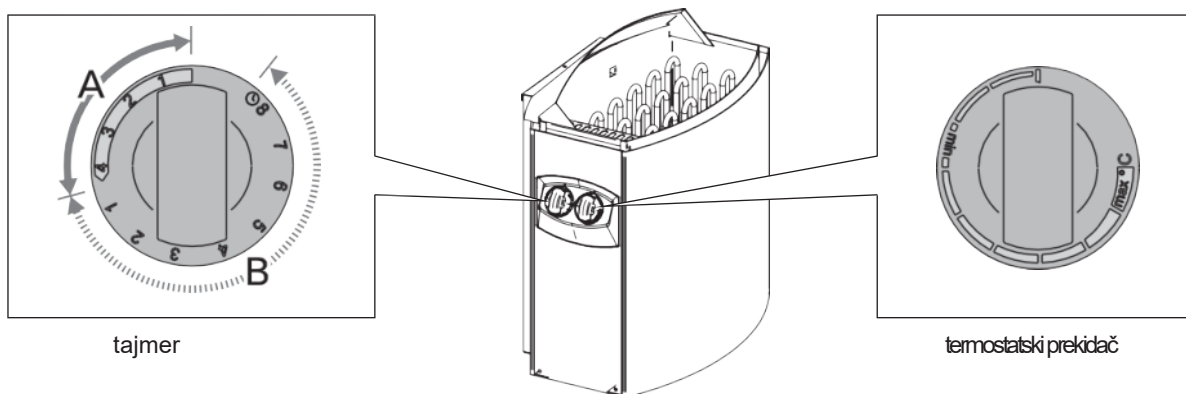

1. Peć

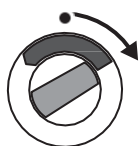

uključivanje

postavite tajmer na "on" (dio A na slici 2, 0-4 sata). Peć se odmah počinje zagrijavati.

2. Unaprijed nastavljeno vrijeme (vremenski kontrolirano uključivanje)



postavite tajmer na dio "Preset" (dio B na slici 2, 0-8 sata). Peć počinje grijati kada tajmer vrati prekidač u položaj "uključeno". Nakon toga grijač će biti uključen oko četiri sata.

Za detaljnije informacije o specifičnoj uporabi i sigurnosnim mjerama opreza za peć za saunu pogledajte upute za uporabu koje ste dobili uz peć za saunu.

Održavanje

Zaštita drva

Nakon što je sauna sastavljena, očistite svaku vanjsku letvu bačve i nanesite glazuru za drvo kako biste zaštitili drvo. Obnovite zaštitu drva u skladu s preporukama proizvođača korištenog proizvoda.

VAŽNO :

Prije početka rada od spojite kabinski kabel za napajanje.

Utvrđen problem	Mogući uzrok	Rješenje
Peć se ne zagrijava.	Kabel za napajanje nije spojen.	Provjerite priključak kabela za napajanje.
	Prekinuta je opskrba električnom energijom.	Provjerite ispravnost osigurača i provjerite napon u utičnici.
	Peć je zaštićena od pregrijavanja.	Pogledajte upute za uporabu peći.
Rasvjeta saune više ne radi.	Kabel za napajanje svjetla nije pravilno spojen.	Ispravno spojite kabel.
	Svjetlo je pokvareno.	Kontaktirajte prodavača.

Čišćenje:

1. Isključite saunu.
2. Usisavačem uklonite prašinu iz pukotina u drvenoj oplati.
3. Očistite kabinu vlažnom pamučnom krpom, po potrebi s malo sapuna. Isperite vlažnom krpom.
4. Očistite staklo sredstvom za čišćenje prozora/stakla i mekom krpom.
5. Njeguajte vanjski dio saune svake 2 godine odgovarajućim sredstvom.

VAŽNO :

Drvo treba tretirati zaštitnim sredstvom samo s vanjske strane saune. Unutrašnjost saune ne smije se obrađivati.

Ne koristite benzin, alkohol, kemikalije ili jaka sredstva za čišćenje saune jer kemijski proizvodi mogu oštetiti drvo. Ne prskajte saunu vodom.

Za montažu i korištenje peći za saunu pročitajte priložene upute.

Grijalicu smije priključiti na električnu mrežu samo ovlašteni električar prema važećim propisima.

BC45, BC60, BC80, BC90 BC45E, BC60E, BC80E, BC90E

EN Instructions for Installation and Use of Electric Sauna Heater

HR Uputstva za upotrebu i montažu električnog grijača / peći saune



B



BC-E

these instructions for installation and use are intended for the owner or the person in charge of the sauna, as well as for the electrician in charge of the electrical installation of the heater. After completing the installation, the person in charge of the installation should give these instructions to the owner of the sauna or to the person in charge of its operation. Please read the instructions for use carefully before using the heater.

the heater is designed for the heating of a sauna room to bathing temperature. It is not to be used for any other purpose.

Congratulations on your choice!

Guarantee:

- the guarantee period for heaters and control equipment used in saunas by families is two (2) years.
- the guarantee period for heaters and control equipment used in saunas by building residents is one (1) year.
- the guarantee does not cover any faults resulting from failure to comply with installation, use or maintenance instructions.
- the guarantee does not cover any faults resulting from the use of stones not recommended by the heater manufacturer.

ContEntS

1. InStRUCtionS FoR USE	3
1.1. Piling of the Sauna Stones	3
1.1.1. Maintenance.....	3
1.2. Heating of the Sauna.....	4
1.3. Using the Heater.....	4
1.3.1. Heater On.....	4
1.3.2. Pre-setting Time (timed switch-on).....	4
1.3.3. Heater Off.....	5
1.3.4. Setting the Temperature.....	5
1.4. Throwing Water on Heated Stones.....	5
1.5. Instructions for Bathing	6
1.6. Warnings.....	6
1.7. Troubleshooting	6
2. SAUnA Room	8
2.1. Sauna Room Structure	8
2.1.1. Blackening of the sauna walls.....	8
2.2. Sauna Room Ventilation	9
2.3. Heater Output	9
2.4. Sauna Room Hygiene	9
3. InStRUCtionS FoR InStALLAtion	10
3.1. Before Installation.....	10
3.2. Fastening the Heater on a Wall	11
3.3. Electrical Connections	12
3.3.1. Electric Heater Insulation Resistance	12
3.4. Installation of the Control Unit and Sensors (BC-E) ..	13
3.5. Resetting the Overheat Protector	13
4. SPARE PARTS	15

Ove upute za montažu i uporabu namijenjene su vlasniku saune ili osobi odgovornoj za održavanje saune i električaru odgovornom za montažu peći za saunu. Prilikom montaže peći za saunu, ove upute za montažu i uporabu predaju se vlasniku saune ili osobi odgovornoj za brigu o sauni. Prije uporabe peći za saunu pažljivo pročitajte upute za uporabu.

Peć služi za zagrijavanje saunske kabine na temperaturu saune. Korištenje u druge svrhe je zabranjeno. Grijalice za saune s oznakom CE zadovoljavaju sve propise za sustave sauna. Nadležna tijela provjeravaju poštivanje ovih propisa.

Čestitamo na dobrom odabiru!

Jamstvo:

- Jamstveni rok za grijače i regulatore koji se koriste u obiteljskim saunama je dvije (2) godine.
- Jamstveni rok za grijače i regulatore za saune koji se koriste u javnim saunama u privatnim zgradama je jedna (1) godina.
- Jamstvo ne pokriva kvarove uzrokovane nepravilnom ugradnjom i uporabom ili nepoštivanjem uputa za održavanje.
- Jamstvo ne pokriva štetu uzrokovanu korištenjem kamenja koje tvornica ne preporučuje.

SADRŽAJ

1. UPUTSTVA ZA UPOTREBU	3
1.1. Slaganje kamenja za saunu.....	3
1.1.1. Održavanje	3
1.2. Zagrijavanje saune.....	4
1.3. Upotreba peći	4
1.3.1. Ukjučivanje peći.....	4
1.3.2. Prednamješteno vrijeme	4
1.3.3. Isključivanje peći	5
1.3.4. Podešavanje temperature.....	5
1.4. Nalijevanje vode na zagrijano kamenje.....	5
1.5. Upute za upotrebu saune.....	6
1.6. Upozorenja	6
1.7. Rješavanje problema	6
2. SAUNA	8
2.1. Struktura saune	8
2.1.1. Crnjenje zidova saune.....	8
2.2. Ventilacija saune	9
2.3. Snaga peći	9
2.4. Čistoća u sauni	9
3. UPUTE ZA MONTAŽU	10
3.1. Prije montaže	10
3.2. Pričvršćivanje peći na zid.....	11
3.3. Električni priključci	12
3.3.1. Izolacijski otpor električne peći za saunu.....	12
3.4. Spajanje upravljačke jedinice i seznora (BC-E)	13
3.5. Resetiranje zaštite od pregrijavanja.....	13
4. REZERVNI DIJELOVI	15

1. InStRUCtIOnS FoR USE

1.1. Piling of the Sauna Stones

The piling of the sauna stones has a great effect on the functioning of the heater (figure 1).

Important information on sauna stones:

- The stones should be 5–10 cm in diameter.
- Use solely angular split-face sauna stones that are intended for use in a heater. Peridotite, olivine-dolerite and olivine are suitable stone types.

neither light, porous ceramic "stones" nor soft soapstones should be used in the heater. they do not absorb enough heat when warmed up. this can result in damage in heating elements.

- Wash off dust from the stones before piling them into the heater.

Please note when placing the stones:

- Do not drop stones into the heater.
- Do not wedge stones between the heating elements.
- Place the stones sparsely to ensure that air can circulate between them.
- Pile the stones so that they support each other instead of lying their weight on the heating elements.
- Do not form a high pile of stones on top of the heater.
- No such objects or devices should be placed inside the heater stone space or near the heater that could change the amount or direction of the air flowing through the heater.

1. UPUTSTVA ZA UPOTREBU

1.1. Slaganje kamenja za saunu

Način slaganja kamenja u ložište uvelike utječe na učinkovitost ložišta (foto. 1).

Važne informacije o kamenju za peći u sauni:

- Kamenje mora imati promjer 5-10 cm.
- Koristite samo kamenje za saunu s oštrim rubovima i hrapavom površinom koje je namijenjeno za korištenje u pećima za saunu. Prikladno kamenje je peridotit, olivin dolerit i olivin.
- **U peći saune ne smijete koristiti lagano porozno kamenje, keramičko kamenje i sl. jer zagrijavanjem ne apsorbira dovoljno topline, što može oštetiti grijače elemente.**
- Prije slaganja kamenja potrebno je ukloniti prašinu od kamenja.

Prilikom postavljanja kamenja obratite pažnju na sljedeće:

- Ne bacajte kamenje u peć.
- Ne stavljajte kamenje između grijača.
- Rasporedite kamenje tako da između njih struji zrak.
- Stavite kamenje jedno na drugo kako ne bi pritiskali grijača tijela.
- Nemojte slagati kamenje u visoku hrpu na vrhu peći.
- U komori za kamenje ili u blizini peći ne smiju se nalaziti predmeti ili uređaji koji mijenjaju količinu ili smjer strujanja zraka kroz saunu.

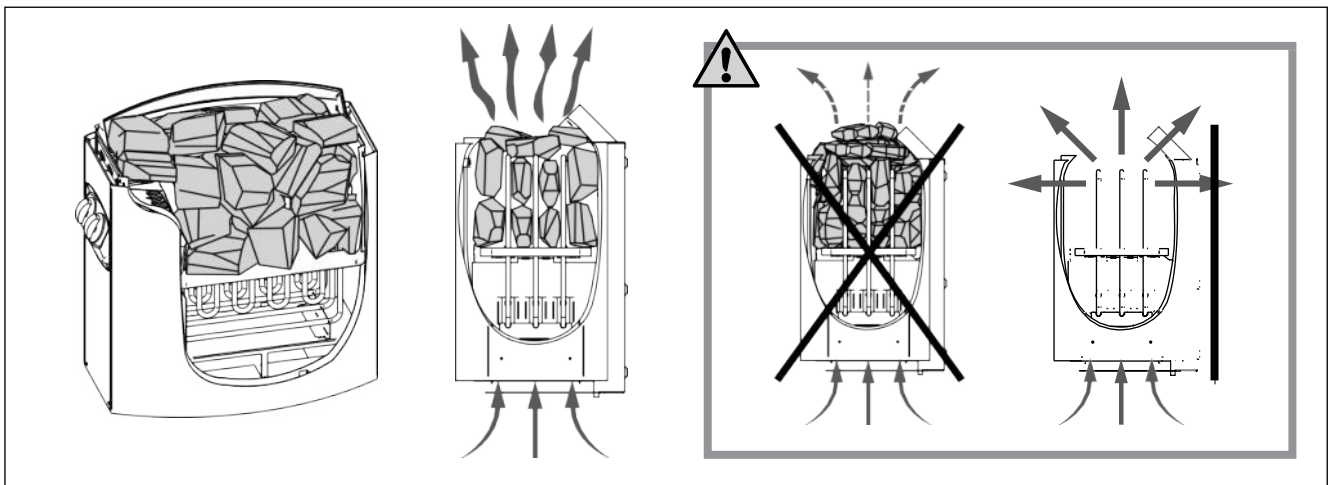

Figure 1. Piling of the sauna stones
Foto 1. Slaganje kamenja za saunu

1.1.1. Maintenance

Due to large variation in temperature, the sauna stones disintegrate in use. Rearrange the stones at least once a year or even more often if the sauna is in frequent use. At the same time, remove any pieces of stones from the bottom of the heater and replace any disintegrated stones with new ones. By doing this, the heating capability of the heater stays optimal and the risk of overheating is avoided.

1.1.1. Održavanje

Kamenje u sauni postaje krto i lomljivo zbog velikih promjena temperature. Kamenje se mora ponovno slagati najmanje jednom godišnje, uz redovitu upotrebu i čišće. Za to vrijeme također uklonite prašinu i krhotine kamenja s donjeg dijela saune i zamijenite oštećeno kamenje. Na taj način ćete održati optimalni kapacitet grijanja pećnice i izbjeći rizik od pregrijavanja.

1.2. Heating of the Sauna

When operating the heater for the first time, both the heater and the stones emit smell. To remove the smell, the sauna room needs to be efficiently ventilated.

If the heater output is suitable for the sauna room, it will take about an hour for a properly insulated sauna to reach the required bathing temperature (2.3.). The sauna stones normally reach the bathing temperature at the same time as the sauna room. A suitable temperature for the sauna room is about 65–80 °C.

1.3. Using the Heater

Before switching the heater on always check that there isn't anything on top of the heater or inside the given safety distance. 1.6.

- Heater models BC45, BC60, BC80 and BC90 are equipped with a timer and a thermostat. The timer is for setting the on-time for the heater and the thermostat is for setting a suitable temperature. 1.3.1.–1.3.4.
- Heater models BC45E, BC60E, BC80E and BC90E are controlled from a separate control unit. See the instructions for use of the selected control unit model.

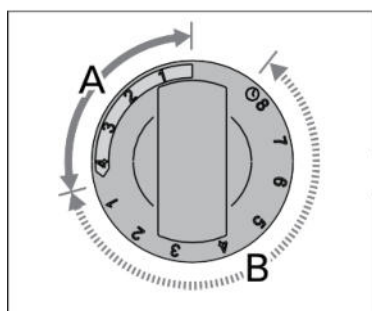

Figure 2. Timer switch
Foto 2. Vremenski prekidač

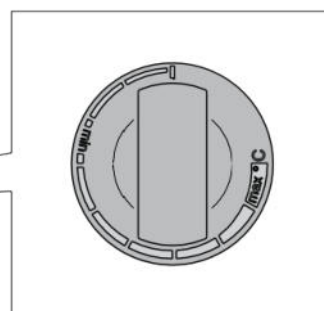
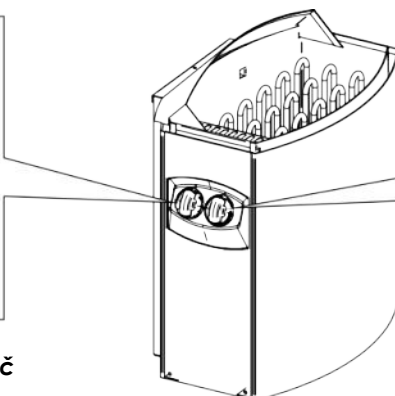

Figure 3. Thermostat switch
Foto 3. Termostat

1.3.1. Heater on



Turn the timer switch to the "on" section (section A in figure 2, 0–4 hours). The heater starts heating immediately.

1.3.2. Pre-setting time (timed switch-on)



Turn the timer switch to the "pre-setting" section (section B in figure 2, 0–8 hours). The heater starts heating when the timer has turned the switch back to the "on" section. After this, the heater will be on for about four hours.

Example: You want to go walking for three hours and have a sauna bath after that. Turn the timer switch to the "pre-setting" section at number 2.

The timer starts. After two hours, the heater starts heating. Because it takes about one hour for the sauna to be heated, it will be ready for bathing after about three hours, that is, when you come back from your walk.

1.2. Grijanje saune

Prilikom prvog zagrijavanja iz grijalice i kamenja za saunu oslobađaju se neugodni mirisi. Da biste ih uklonili, saunu je potrebno temeljito provjetravati.

Ako je snaga grijača prikladna za saunu, pravilno izoliranoj sauni trebat će oko sat vremena da postigne potrebnu temperaturu saune. (2.3.). Kamenje za saunu obično se zagrijava na temperaturu infuzije u isto vrijeme kada i kabina saune. Idealna temperatura u kabini saune je otprilike 65 do 80 °C.

1.3. Korištenje peći

Prije paljenja štednjaka provjerite da nema nikakvih predmeta na štednjaku ili u njegovoj neposrednoj blizini. 1.6.

- Modeli peći BC45, BC60, BC80 in opremljeni su timerom i termostatom. Tajmer regulira vrijeme uključenosti peći, a termostat regulira temperaturu. 1.3.1.–1.3.4.
- Modeli peći BC45E, BC60E, BC80E in BC90E upravlja posebna upravljačka jedinica. Slijedite upute za uporabu isporučene s upravljačkom jedinicom.

1.3.1. Uključivanje peći



Postavite tajmer na položaj "on" (odjelak A i foto. 2, 0–4 sata). Peć se odmah počinje zagrijavati.

1.3.2. Unaprijed podešeno vrijeme (vremenski kontrolirano uključivanje)



Postavite tajmer na položaj "unaprijed postavljen" (odjelak B in foto. 2, 0–8 sata). Pećnica se počinje zagrijavati kada se tajmer okrene na "on". Zatim peć stoji oko četiri sata.

Primjer: želite hodati tri sata, a zatim se saunirati u sauni. Postavite tajmersku sklopku u odjeljku "Preset" na broj 2.

Mjerač vremena počinje raditi. Nakon dva sata grijač se počinje zagrijavati. Kako se sauna zagrijava oko sat vremena, bit će spremna za korištenje nakon otprilike tri sata, tj. kad se vratite iz šetnje.

1.3.3. Heater off



The heater switches off, when the timer turns the switch back to zero. You can switch the heater off at any time by turning the timer switch to zero yourself.

Switch the heater off after bathing. Sometimes it may be advisable to leave the heater on for a while to let the wooden parts of the sauna dry properly.

notE! Always check that the heater has switched off and stopped heating after the timer has turned the switch to zero.

1.3.4. Setting the temperature

The purpose of the thermostat (figure 3) is to keep the temperature in the sauna room on a desired level. By experimenting, you can find the setting that suits you best.

Begin experimenting at the maximum position. If, during bathing, the temperature rises too high, turn the switch counter-clockwise a little. Note that even a small difference within the maximum section will change the temperature of the sauna considerably.

1.4. throwing Water on Heated Stones

The air in the sauna room becomes dry when warmed up. Therefore, it is necessary to throw water on the heated stones to reach a suitable level of humidity in the sauna. The effect of heat and steam on people varies – by experimenting, you can find the levels of temperature and humidity that suit you best.

notE! the maximum volume of the ladle is 0.2 litres. If an excessive amount of water is poured on the stones, only part of it will evaporate and the rest may splash as boiling hot water on the bathers. never throw water on the stones when there are people near the heater, because hot steam may burn their skin.

notE! the water to be thrown on the heated stones should meet the requirements of clean household water (table 1). only special aromas designed for sauna water may be used. Follow the instructions given on the package.

1.3.3. Isključivanje peći



Peć se gasi kada se tajmer vrati na nulu. Peć možete sami isključiti u bilo kojem trenutku postavljanjem prekidača timera na nulu. Nakon saunanja ugasiite peć.

Ponekad se preporuča ostaviti peć neko vrijeme uključenom kako bi se drveni dijelovi saune dobro osušili.

PAŽNJA! Uvijek provjerite je li peć isključena i više ne grije kada se mjerač vremena poništi.

1.3.4. Podešavanje temperature

Namjena termostata (Foto. 3) je održavanje željene temperature u sauni. Pokušajte koja vam postavka najbolje odgovara.

Počnite s najvišom postavkom. Ako temperatura tijekom saune previsoko poraste, lagano okrenite prekidač u smjeru suprotnom od kazaljke na satu. Imajte na umu da čak i male promjene u gornjem temperaturnom rasponu imaju veliki utjecaj na temperaturu u sauni.

1.4. Nalijevanje vode na zagrijano kamenje

Zrak u sauni se zagrijavanjem isušuje, pa se voda mora izljevati na vruće kamenje saune kako bi se postigla ugodna razina vlažnosti. Učinci topline i pare razlikuju se od osobe do osobe, pa eksperimentirajte s temperaturom i razinom vlažnosti koja vam najviše odgovara.

PAŽNJA! Volumen kutlače za točenje vode ne smije biti veći od 0,2 litre. Nemojte odjednom izljevati velike količine vode na kamenje jer bi kipuća voda mogla poprskati ljude u sauni dok isparava. Također, pazite da kamenje ne polijete vodom kada je netko u njegovoj blizini. Vruća para može izazvati opekline.

PAŽNJA! Za navodnjavanje se smije koristiti samo voda koja zadovoljava uvjete kakvoće za vodu za kućanstvo (Tablica 1). U vodi za doziranje određeni mirisi mogu se koristiti samo u tu svrhu. Slijedite upute na pakiranju.

Water property Svojstva vode	Effect Učinak	Recommendation Preporučeno
Humus concentration Sadržaj humusa	Colour, taste, precipitates Boja, okus, sediment	<12 mg/l
Iron concentration Sadržaj željeza	Colour, odour, taste, precipitates Boja, miris, okus, sediment	<0,2 mg/l
Hardness: most important substances are manganese (Mn) and lime, i.e. calcium (Ca). Tvrdća vode: najvažnije tvari su mangan (Mn) i vodeni kamenac, tj. kalcij (Ca).	Precipitates Sediment	Mn: <0,05 mg/l Ca: <100 mg/l
Chlorinated water Klorirana voda	Health risk Štetno za zdravlje	Forbidden to use Ne smije se koristiti
Seawater Slana voda	Rapid corrosion Brza korozija	Forbidden to use Ne smije se koristiti

Table 1. Water quality requirements
Tablica 1. Zahtjevi za kvalitetom vode

1.5. Instructions for Bathing

- Begin by washing yourself.
- Stay in the sauna for as long as you feel comfortable.
- Forget all your troubles and relax.
- According to established sauna conventions, you must not disturb other bathers by speaking in a loud voice.
- Do not force other bathers from the sauna by throwing excessive amounts of water on the stones.
- Cool your skin down as necessary. If you are in good health, you can have a swim if a swimming place or pool is available.
- Wash yourself after bathing.
- Rest for a while and let your pulse go back to normal. Have a drink of fresh water or a soft drink to bring your fluid balance back to normal.

1.6. Warnings

- **Staying in the hot sauna for long periods of time makes the body temperature rise, which may be dangerous.**
- **Keep away from the heater when it is hot. the stones and outer surface of the heater may burn your skin.**
- **Keep children away from the heater.**
- **Do not let young, handicapped or ill people bathe in the sauna on their own.**
- **Consult your doctor about any health-related limitations to bathing.**
- **Consult your child welfare clinic about taking little babies to the sauna.**
- **Be very careful when moving in the sauna, as the platform and floors may be slippery.**
- **never go to a hot sauna if you have taken alcohol, strong medicines or narcotics.**
- **never sleep in a hot sauna.**
- **Sea air and a humid climate may corrode the metal surfaces of the heater.**
- **Do not hang clothes to dry in the sauna, as this may cause a risk of fire. Excessive moisture content may also cause damage to the electrical equipment.**

1.7. troubleshooting

note! All service operations must be done by professional maintenance personnel.

the heater does not heat.

- Check that the fuses to the heater are in good condition.
- Check that the connection cable is connected (▶ 3.3.).
- Turn the timer switch to the "on" section (▶ 1.3.1.).
- Turn the thermostat to a higher setting (▶ 1.3.4.).
- Check that the overheat protector has not gone off. The timer works but the heater does not heat. (▶ 3.5.)

the sauna room heats slowly. the water thrown on the sauna stones cools down the stones quickly.

- Check that the fuses to the heater are in good

1.5. Uputstva za upotrebu saune

- Istuširajte se prije saune.
- Ostanite u sauni onoliko dugo koliko vam je ugodno.
- Zaboravite na stres i opustite se.
- Dobre navike u sauni uključuju obzirnost prema drugima, kako ih ne bi uznemiravali nepotrebnom bukom.
- Ne tjerajte druge kupače iz saune bacanjem prevelike količine vode na kamenje.
- U međuvremenu pričekajte da se zagrijana koža ohladi. Ako ste dobrog zdravlja i imate priliku, plivajte.
- Istuširajte se nakon saune.
- Odmorite se dok ne osjetite ravnotežu. Pijte običnu vodu ili gazirana pića kako biste uravnotežili ravnotežu tekućine.

1.6. Upozorenja

- Dugotrajni boravak u vrućoj sauni uzrokuje povećanje tjelesne temperature, što može biti opasno.
- Čuvajte se vrućih grijača za saunu. Kamenje i kućište su vrlo vrući i mogu opeći kožu.
- Spriječite djeci pristup peći.
- Djeca, osobe s poteškoćama u hodu, bolesne i slabe osobe ne smiju biti same u sauni.
- O medicinskim ograničenjima korištenja saune potrebno je konzultirati se s liječnikom.
- Posavjetujte se s djetetovim liječnikom o korištenju saune za malu djecu.
- Ne idite u saunu ako ste pod utjecajem droga, alkohola, lijekova i sl.
- Nikada ne spavajte u zagrijanoj sauni.
- More i vlažna klima mogu uzrokovati hrđanje metalnih površina peći za saunu.
- Nemojte koristiti saunu za sušenje odjeće ili rublja jer postoji opasnost od požara; osim toga, visoka vlažnost može oštetiti električne uređaje.

1.7. Rješavanje problema

Pažnja! Sve radove održavanja mora izvoditi kvalificirano tehničko osoblje.

Peć se ne zagrijava.

- Provjerite jesu li osigurači u peći u dobrom stanju.
- Provjerite je li spojni kabel priključen (3.3.).
- Postavite vremenski prekidač u položaj "on" (1.3.1.).
- Postavite termostat na višu vrijednost (1.3.4.).
- Provjerite je li aktivirana zaštita od pregrijavanja. Tajmer radi, ali se pećnica ne zagrijava. (3.5.)

Kabina saune se presporo zagrijava. Voda koja se polije po kamenju saune brzo hladi kamenje.

condition.

- Check that all heating elements glow when the heater is on.
- Turn the thermostat to a higher setting (▶ 1.3.4.).
- Check that the heater output is sufficient (▶ 2.3.).
- Check the sauna stones (▶ 1.1.). Too tightly piled stones, the settling of stones with time or wrong stone type can hinder the air flow through the heater, which results in reduced heating efficiency.
- Check that the sauna room ventilation has been arranged correctly (▶ 2.2.).

the sauna room heats quickly, but the temperature of the stones remain insufficient. Water thrown on the stones runs through.

- Turn the thermostat to a lower setting (▶ 1.3.4.).
- Check that the heater output is not too high (▶ 2.3.).
- Check that the sauna room ventilation has been arranged correctly (▶ 2.2.).

the sauna room heats unevenly.

- Check that the heater has been installed in the correct height. The heater heats the sauna best, when it is installed 100 mm from the floor. The maximum installation height is 200 mm. (▶ 3.2.)

Panel or other material near the heater blackens quickly.

- Check that the requirements for safety distances are fulfilled (▶ 3.1.).
- Check the sauna stones (▶ 1.1.). Too tightly piled stones, the settling of stones with time or wrong stone type can hinder the air flow through the heater, which may result in overheating of surrounding materials.
- Also see section 2.1.1.

the heater emits smell.

- See section 1.2.
- The hot heater may emphasize odours mixed in the air that are not, however, caused by the sauna or the heater. Examples: paint, glue, oil, seasoning.

the heater makes noise.

- BC: The timer is a mechanical device and it makes a ticking sound when it is functioning normally. If the timer ticks even when the heater is switched off, check the timer's wiring.
- Occasional bangs are most likely caused by stones cracking due to heat.
- The thermal expansion of heater parts can cause noises when the heater warms up.

- Provjerite jesu li osigurači u peći u dobrom stanju.
- Provjerite svijetle li svi grijaći elementi kada je peć uključena.
- Postavite termostat na višu vrijednost (1.3.4.).
- Provjerite da li je snaga peći dovoljna (2.3.).
- Provjerite kamenje u peći (1.1.). Pretijesno slaganje kamenja, taloženje kamenja i krive vrste kamenja mogu ometati protok zraka kroz peć, smanjujući učinkovitost grijanja česar se zmanjša učinkovitost ogrevanja.
- Provjerite je li ventilacija u sauni pravilno podešena (▶ 2.2.).

Sauna se brzo zagrijava, ali temperatura kamenja je nedovoljna. Protječe voda koja se izlijeva na kamenje.

- Postavite termostat na nižu vrijednost (1.3.4.).
- Provjerite da snaga peći nije previsoka (2.3.).
- Provjerite je li ventilacija kabine saune pravilno postavljena (▶ 2.2.).

Sauna se neravnomjerno zagrijava.

- Provjerite je li peć postavljena na odgovarajuću visinu. Peć najbolje zagrijava saunu ako je postavljena 100 mm iznad poda. Maksimalna visina ugradnje je 200 mm. (▶ 3.2.)

Ploče i drugi materijali u blizini peći brzo crne.

- Provjerite jesu li ispunjeni zahtjevi sigurnosne udaljenosti (3.1.).
- Provjerite kamenje u peći (1.1.). Pretijesno zbijeno kamenje, taloženje kamena i nepravilno kamenje mogu ometati protok zraka kroz peć, što može uzrokovati pregrijavanje okolnih materijala.
- Vidi također 2.1.1.

Peć ispušta neugodne mirise.

- Vidi 1.2.
- Vruća peć može povećati mirise u zraku koji nisu uzrokovani saunom ili samom peći. Primjeri: boje, ljepilo, ulje, začini.

Peć buči.

- BC: mjerač vremena je mehanički uređaj, pa proizvodi otkucavajući zvuk tijekom normalnog rada. Ako se zvuk otkucaja čuje iako peć nije uključena, provjerite veze tajmera.
- Naglo pucanje ponekad je uzrokovano kamenjem koje puca zbog topline.
- Širenje dijelova peći zbog topline može uzrokovati buku kada se peć zagrijava.

2. SAUnA Room

2. SAUNA

2.1. Sauna Room Structure

2.1. Struktura saune

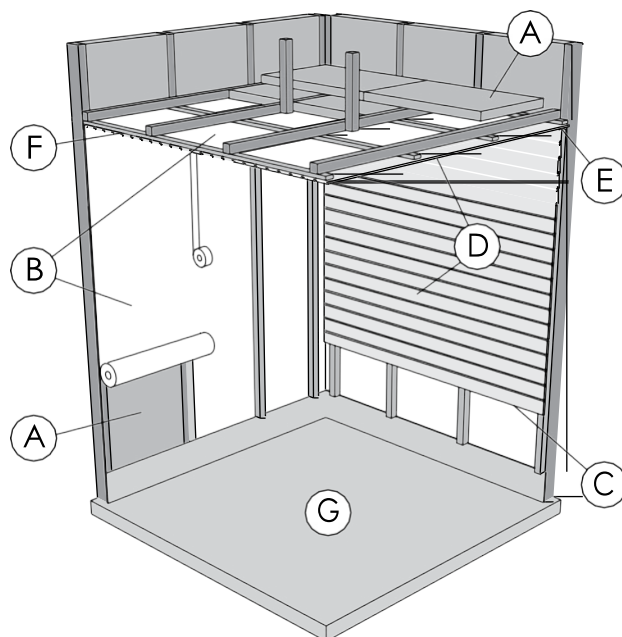

Figure 4.
Foto 4.

- A. Insulation wool, thickness 50–100 mm. The sauna room must be insulated carefully so that the heater output can be kept moderately low.
- B. Moisture protection, e.g. aluminium paper. Place the glossy side of the paper towards the sauna. Tape the seams with aluminium tape.
- C. Vent gap of about 10 mm between the moisture protection and panel (recommendation).
- D. Low mass 12–16 mm thick panel board. Before starting the panelling, check the electric wiring and the reinforcements in the walls required by the heater and benches.
- E. Vent gap of about 3 mm between the wall and ceiling panel.
- F. The height of the sauna is usually 2100–2300 mm. The minimum height depends on the heater (see table 2). The space between the upper bench and ceiling should not exceed 1200 mm.
- G. Use floor coverings made of ceramic materials and dark joint grouts. Particles disintegrating from the sauna stones and impurities in the sauna water may stain and/or damage sensitive floor coverings.

notE! Check from the fire authorities which parts of the firewall can be insulated. Flues which are in use must not be insulated.

notE! Light protective covers which are installed directly to the wall or ceiling may be a fire risk.

2.1.1. Blackening of the sauna walls

It is perfectly normal for the wooden surfaces of the sauna room to blacken in time. The blackening may be accelerated by

- sunlight
- heat from the heater
- protective agents on the walls (protective agents have a poor heat resistance level)
- fine particles disintegrating from the sauna stones which rise with the air flow.

- A. Izolacijska vuna debljine 50-100 mm. Kabina saune mora biti pažljivo izolirana kako peć ne bi morala davati preveliku snagu.
- B. Zaštita od vlage, npr. aluminijska folija. Sjajna strana papira treba biti okrenuta prema sauni. Zalijepite šavove aluminijskom trakom.
- C. Otprilike 10 mm zraka između barijere za vlagu i obloge (preporuka).
- D. Lagani premaz debljine 12-16 mm. Prije početka oblaganja provjerite električne instalacije i potrebna pojačanja za peć i klupe u zidovima.
- E. Otprilike 3 mm zraka između zidne i stropne obloge.
- F. Visina saune je obično 2100-2300 mm. Minimalna visina ovisi o peći (vidi tablicu 2). Razmak između gornje klupe i stropa mora biti najviše 1200 mm.
- G. Koristite keramičke podove i tamnu fuginu masu. Čestice koje izlaze iz kamenja za saunu i nečistoće u vodi mogu promijeniti boju ili oštetiti osjetljive podove.
PAŽNJA! Raspitajte se kod nadležnih tijela koji se dio protupožarnog zida može izolirati. Dimnjaci koji su u uporabi ne smiju biti izolirani..
PAŽNJA! Lagani zaštitni poklopci pričvršćeni izravno na zid ili strop predstavljaju opasnost od požara.

2.1.1. Crnjenje zidova saune

Potpuno je normalno da drvene površine saune s vremenom izgube boju. Crnjenje se ubrzava:

- sunčeva svjetlost
- toplina peći
- zaštita zidnih obloga (s niskim toplinskim otporom)
- fine čestice izlaze u zrak iz raspadajućeg kamenja za saunu.

2.2. Sauna Room Ventilation

The air in the sauna room should change six times per hour. Figure 5 illustrates different sauna room ventilation options.

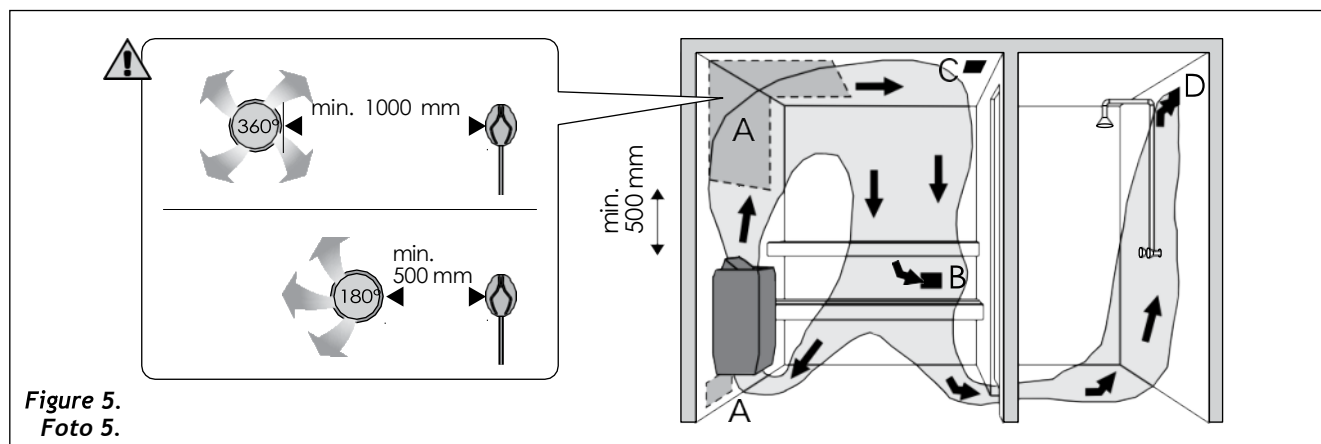

Figure 5.
Foto 5.

- A. Supply air vent location. If mechanical exhaust ventilation is used, place the supply air vent above the heater. If gravity exhaust ventilation is used, place the supply air vent below or next to the heater. The diameter of the supply air pipe must be 50–100 mm. **BC-E: Do not place the supply air vent so that the air flow cools the temperature sensor (see the temperature sensor installation instructions in the control unit installation instructions)!**
- B. Exhaust air vent. Place the exhaust air vent near the floor, as far away from the heater as possible. The diameter of the exhaust air pipe should be twice the diameter of the supply air pipe.
- C. Optional vent for drying (closed during heating and bathing). The sauna can also be dried by leaving the door open after bathing.
- D. If the exhaust air vent is in the washroom, the gap underneath the sauna door must be at least 100 mm. Mechanical exhaust ventilation is mandatory.

2.3. Heater output

When the walls and ceiling are covered with panels and insulation behind the panels is adequate, the heater output is defined according to the volume of the sauna. Non-insulated walls (brick, glass block, glass, concrete, tile, etc.) increase the need for heater output. Add 1,2 m³ to the volume of the sauna for each non-insulated wall square meter. For example, a 10 m³ sauna room with a glass door equals the output requirement of about a 12 m³ sauna room. If the sauna room has log walls, multiply the sauna's volume by 1,5. Choose the correct heater output from table 2.

2.4. Sauna Room Hygiene

Bench towels should be used during bathing to prevent sweat from getting onto the benches.

The benches, walls and floor of the sauna should be washed thoroughly at least every six months. Use a scrubbing brush and sauna detergent.

Wipe dust and dirt from the heater with a damp cloth. Remove lime stains from the heater using a 10% citric acid solution and rinse.

2.2. Ventilacija saune

Zrak u sauni treba mijenjati šest puta na sat. Slika 5 prikazuje različite mogućnosti ventilacije za saunu.

- A. Dovod zraka. U slučaju mehaničke ventilacije ugradite dovod zraka iznad peći. U slučaju gravitacijske ventilacije, ugradite dovod zraka ispod ili pored peći. Promjer cijevi za dovod zraka treba biti 50-100 mm. **BC-E: nemojte instalirati dovod zraka na takav način da hladi osjetnik temperature (za ugradnju osjetnika temperature pogledajte upute za montažu upravljačke jedinice)!**
- B. Ventilacija. Otvor postavite blizu poda, što dalje od peći. Promjer ventilacijske cijevi trebao bi biti dvostruko veći od promjera cijevi za dovod zraka.
- C. Dodatna ventilacija za sušenje (sa zatvorenim grijanjem i kadom). Saunu možete sušiti i kroz otvorena vrata.
- D. Ako je ventilacijski otvor u kupaonici, razmak ispod vrata saune mora biti najmanje 100 mm. Mehanička ventilacija je obavezna.

2.3. Snaga peći

Ako su zid i strop obloženi i dobro izolirani, snaga peći ovisi o volumenu saune. Neizolirani zidovi (kamen, stakleni blokovi, staklo, beton, pločice) povećavaju potrebnu snagu peći. Svaki kvadratni metar neizoliranog zida znači 1,2 m³ više volumena saune. Tako npr. kabina saune od 10 m³ sa staklenim vratima po snazi odgovara sauni od 12 m³. Za zidove s nosačima, volumen saune pomnožite s 1,5. Odaberite odgovarajuću snagu pećnice iz tablice 2.

2.4. Čistoća u sauni

Za zaštitu klopi pred znojem uporabite brisače. Očistite klopi, stene in tla savne vsaj vsakih šest mesecev. Uporabljajte krtačo in čistilo za savno. Obrisite prah in umazanijo s peči z vlažno krpo. Obloge vodnega kamna na peči odstranite z 10 % citrsko kislino in sperite.

3. InStRUCtIoNS FoR InStALLAtIoN

3.1. Before Installation

Before installing the heater, study the instructions for installation. Check the following points:

- Is the output and type of the heater suitable for the sauna room? **the cubic volumes given in table 2 should be followed.**
- Is the supply voltage suitable for the heater?
- The location of the heater fulfils the minimum requirements concerning safety distances given in fig. 6 and table 2.

It is absolutely necessary to install the heater according to these values. neglecting them causes a risk of fire. only one electrical heater may be installed in the sauna room.

3. UPUTE ZA MONTAŽU

3.1. Prije montaže

Prije postavljanja saune pročitajte upute za postavljanje i provjerite sljedeće:

- Da li peč za saunu koja se ugrađuje odgovara snazi i tipu sauni kabini? **Vrijednosti veličine prostorije iz tablice 2 ne smiju biti prekoračene ili manje.**
- Je li mrežni napon prikladan za saunu?
- Položaj peći je u skladu s minimalnim sigurnosnim udaljenostima navedenim na slici 6 i u tablici 2.

Te se udaljenosti moraju strogo pridržavati jer svako odstupanje stvara opasnost od požara. U saunu se može postaviti samo jedna peč.

Heater Peć	Out-put Šna ga	Sauna room Sauna			Electrical connections Električni priključci				
		Cubic vol. Volumen		Height Visina	400 V 3N~ Connecting cable Spojni kabel		Fuse Osigurač	230 V 1N~ Connecting cable Spojni kabel	
Model and dimensions/ Model in dimenzije		min. m ³	max. m ³	min. mm	mm ²	A	mm ²	A	mm ²
Width/širina • BC 480 mm • BC-E 450 mm Depth/dubina 310 mm Height/visina 540 mm Weight/težina 11 kg Stones/kamenje max. 20 kg		2.3.			See fig. 8. The measurements apply to the connecting cable only! Vidi foto 8. Mjere se odnose isključivo na priključni kabel!				
BC45/BC45E	4,5	3	6	1900	5 x 1,5	3 x 10	3 x 2,5	1 x 20	4 x 0,25
BC60/BC60E	6,0	5	8	1900	5 x 1,5	3 x 10	3 x 2,5	1 x 35	4 x 0,25
BC80/BC80E	8,0	7	12	1900	5 x 2,5	3 x 16	3 x 6	1 x 35	4 x 0,25
BC90/BC90E	9,0	8	14	1900	5 x 2,5	3 x 16	3 x 10	1 x 50	4 x 0,25

Table 2. Installation details
Tablica 2. Upute za montažu

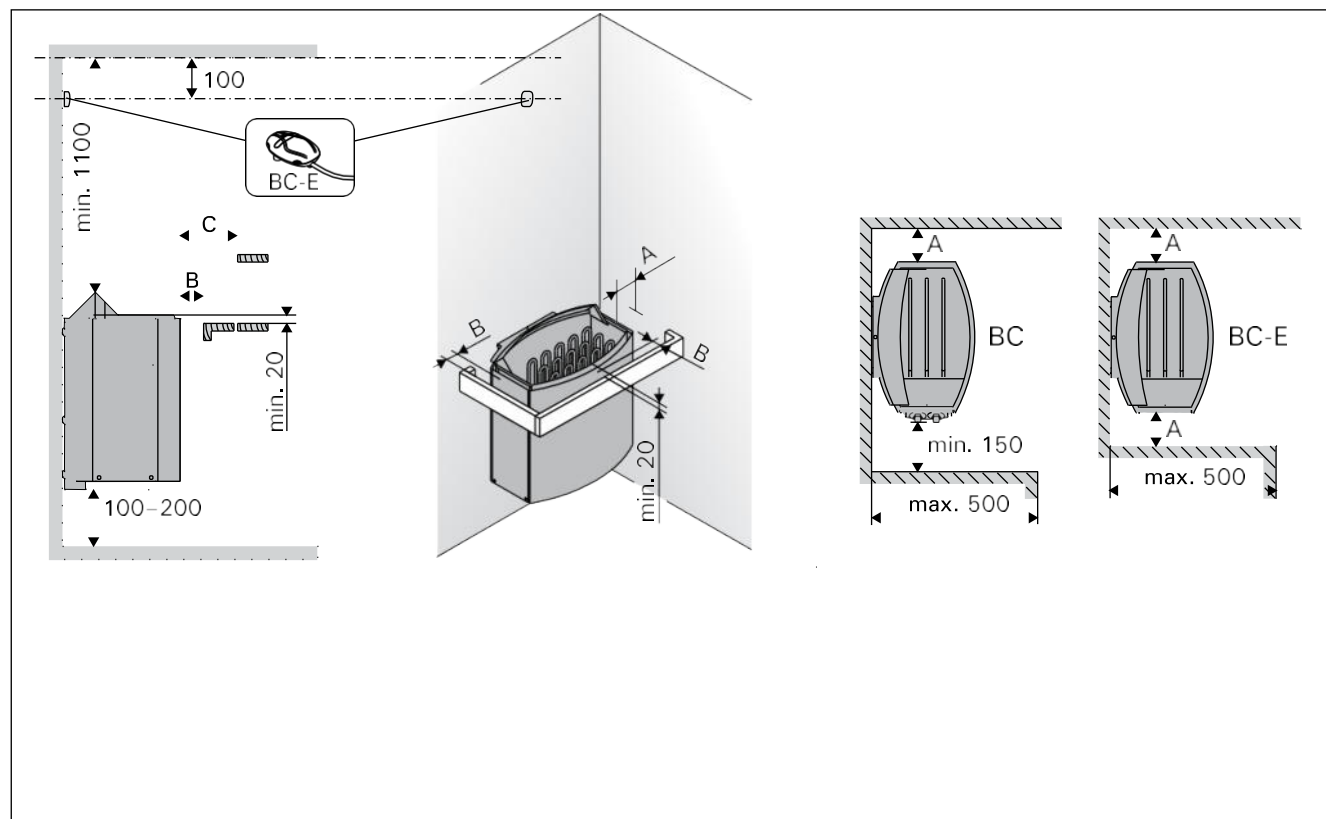

Figure 6. Safety distances (all dimensions in millimeters)
Foto 6. Minimalne sigurnosne udaljenosti (sve dimenzije u milimetrima)

3.2. Fastening the Heater on a Wall

See figure 7.

1. Remove both cardboard covers before installation.
2. Fasten the wall-mounting rack on the wall by using the screws which come with the rack. **notE! there must be a support, e.g. a board, behind the panel, so that the fastening screws can be screwed into a thicker wooden material than the panel. If there are no boards behind the panel, the boards can also be fastened on the panel.**
3. The right- or left-handedness of the heater can be changed by installing it to the rack correspondingly. Make sure the clip fastens in the hole properly.
4. Lift the heater to the rack on the wall so that the fastening hooks of the lower part of the rack go behind the edge of the heater body. Lock the edge of the heater onto the rack by a screw.

3.2. Pričvršćivanje peći na zid

Vidi sliku 7.

1. Prije montaže uklonite oba zaštitna poklopca!
2. Pričvrstite montažni okvir na zid isporučenim vijcima. **PAŽNJA! Na mjestima gdje su pričvršćeni vijci za pričvršćivanje iza panela mora biti materijal koji služi kao oslonac u koji se vijci čvrsto usidre. Ako nema ploča iza ploča, možete ih postaviti i ispred ploča.**
3. Peć za saunu može se različito montirati na zid za dešnjake i ljevoruke korisnike. Provjerite jesu li petlje za pričvršćivanje pravilno postavljene na predviđenim točkama za vješanje.
4. Podignite peć za saunu na okvir na zidu tako da kuke za pričvršćivanje na dnu okvira budu blizu ruba kućišta peći za saunu. Vijcima pričvrstite gornji rub peći za saunu na montažni okvir.

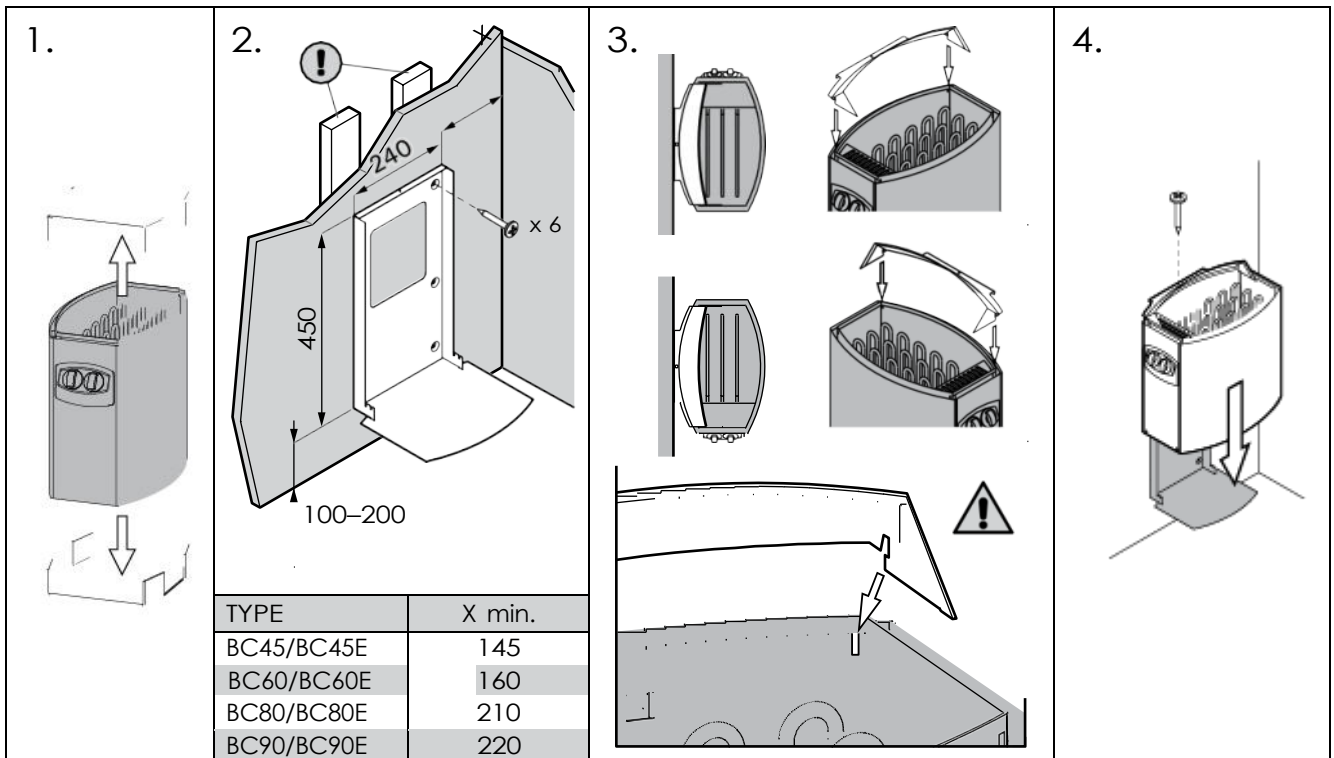

Figure 7. Fastening the heater on a wall (all dimensions in millimeters)
Foto 7. Pričvršćivanje peći na zid (sve dimenzije u milimetrima)

3.3. Electrical Connections

the heater may only be connected to the electrical network in accordance with the current regulations by an authorised, professional electrician.

- The heater is semi-stationarily connected to the junction box (figure 8: A) on the sauna wall. The junction box must be splash-proof, and its maximum height from the floor must not exceed 500 mm.
- The connecting cable (figure 8: B) must be of rubber cable type H07RN-F or its equivalent. **notE! Due to thermal embrittlement, the use of PVC-insulated wire as the connecting cable of the heater is forbidden.**
- If the connecting and installation cables are higher than 1000 mm from the floor in the sauna or inside the sauna room walls, they must be able to endure a minimum temperature of 170 °C when loaded (for example, SSJ). Electrical equipment installed higher than 1000 mm from the sauna floor must be approved for use in a temperature of 125 °C (marking T125).
- In addition to supply connectors, the BC heaters are equipped with a connector (P), which makes the control of the electric heating possible (figure 10). Voltage control is transmitted from the heater when it is switched on. The control cable for electrical heating is brought directly into the junction box of the heater, and from there to the terminal block of the heater along a rubber cable with the same cross-section area as that of the connecting cable.
- **When closing the cover of the connection box make sure that the upper edge of the cover is placed correctly.** If the upper edge is misplaced water can enter the connection box. Figure 8.

3.3. Električni priključci:

Samo ovlašteni električar može spojiti peć za saunu na električnu mrežu u skladu s važećim propisima.

- Peć za saunu je djelomično trajno pričvršćena na priključnu kutiju (Slika 7: A) na zidu saune. Priključna kutija mora biti zaštićena od prskanja vode i ne smije se postavljati više od 500 mm iznad poda.
- Kao spojni kabel koristi se gumeni kabel tipa H07RN-F ili ekvivalentni kabel (slika 8: B). **PAŽNJA! Kabeli s PVC izolacijom ne smiju se koristiti kao priključni kabeli za saunu zbog njihove slabe toplinske otpornosti.**
- Ako spojni ili instalacijski kabeli ulaze u saunu ili zidove saune na visini većoj od 1000 mm iznad poda, moraju pod opterećenjem izdržati temperaturu od najmanje 170 °C (npr. SSJ). Električni uređaji ugrađeni više od 1000 mm od poda saune moraju biti odobreni za uporabu pri temperaturi okoline od 125 °C (Napomena T125).
- BC peći za saune opremljene su priključkom (P) koji omogućuje upravljanje električnim grijanjem (slika 9). Kada je peć uključena, ona preuzima kontrolu nad naponom. Upravljački kabel za električno grijanje vodi se direktno u priključnu kutiju peći za saunu, a odatle se preko gumenog kabela iste debljine vodi do priključne kutije peći za saunu.
- **Prilikom zatvaranja poklopca kutije za punjenje, pazite da se poklopac potpuno zatvori. Ako poklopac nije ispravno postavljen, voda može teći u razvodnu kutiju.** Foto 8.

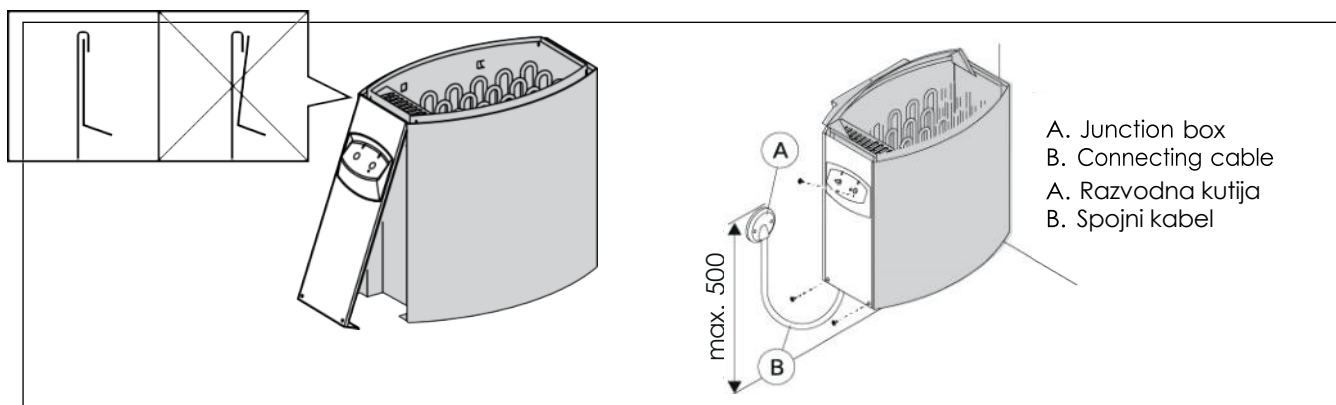

Figure 8. Closing the cover of the connection box (all dimensions in millimeters)
Foto 8. Zatvaranje priključne kutije (sve dimenzije u milimetrima)

3.3.1. Electric Heater Insulation Resistance

When performing the final inspection of the electrical installations, a "leakage" may be detected when measuring the heater's insulation resistance. The reason for this is that the insulating material of the heating elements has absorbed moisture from the air (storage, transport). After operating the heater for a few times, the moisture will be removed from the heating elements.

Do not connect the power feed for the heater through the RCD (residual current device)!

3.3.1. Izolacijski otpor električne peći za saunu

Prilikom završnog pregleda električnih instalacija, prilikom mjerenja otpora izolacije, može doći do "curenja" koje je posljedica prodora vlage iz zraka u izolacijski materijal otpornika grijanja (tijekom skladištenja i transporta). Vлага izlazi iz otpornika nakon dva zagrijavanja.

Ne spajajte napajanje grijača preko RCD-a (uređaj zaostalih struja)!

3.4. Installation of the Control Unit and Sensors (BC-E)

The control unit includes detailed instructions for fastening the unit on the wall. Install the temperature sensor on the wall of the sauna room above the heater. It should be installed on the lateral centre line of the heater, 100 mm downwards from the ceiling. Figure 6.

Do not place the supply air vent so that the air flow cools the temperature sensor. Figure 5.

3.5. Resetting the overheat Protector

If the temperature of the sauna room becomes dangerously high, the overheat protector will permanently cut off the supply of the heater. The overheat protector can be reset after the heater has cooled down.

BC

The reset button is located inside the heater's connection box (figure 9). **only persons authorised to carry out electrical installations can reset the overheat protector.**

Prior to pressing the button, the cause of the fault must be found.

- Are the stones crumbled and pressed together?
- Has the heater been on for a long time while unused?
- Is the sensor of the thermostat out of place or broken?
- Has the heater been banged or shaken?

BC-E

See the installation instructions for control unit.

3.4. Spajanje upravljačke jedinice i senzora (BC-E)

Što se tiče upravljačke jedinice, dane su detaljne upute o tome kako je pričvrstiti na zid. Senzor temperature postavlja se na zid saune iznad peći, 100 mm ispod stropa na osi u smjeru širine saune. Foto 6. **Nemojte postavljati uređaj za dovod zraka na način da hladi senzor temperature. Foto 5.**

3.5. Resetiranje zaštite od pregrijavanja

Ako temperatura u kabini saune opasno poraste, zaštita od pregrijavanja trajno prekida napajanje peći. Zaštita od pregrijavanja se može resetirati kada se peć ohladi.

BC

Gumb za resetiranje nalazi se u priključnoj kutiji peći (slika 8). **Ove radove smije obavljati samo osoba koja je ovlaštena za izvođenje električnih instalacija.**

Prije pritiska na tipku potrebno je utvrditi uzrok kvara:

- Je li kamenje mrvljeno i stisnuto jedno uz drugo?
- Je li peć za saunu dugo bila uključena i nije se koristila?
- Je li senzor termostata na krivom mjestu ili je neispravan?
- Je li peć za saunu bila izložena jakim udarcima?

BC-E

Pogledajte upute za montažu upravljačke jedinice.

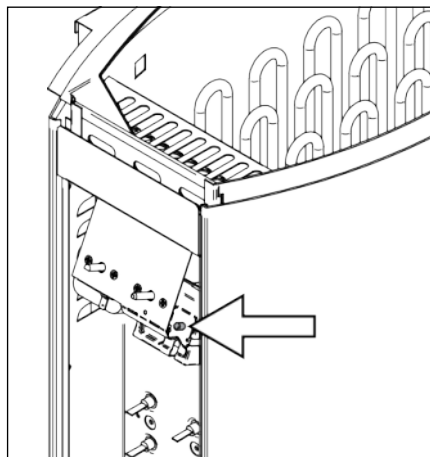

Figure 9.
Foto 9.

Reset button for overheat protector
Tipka za resetiranje zaštite od pregrijavanja

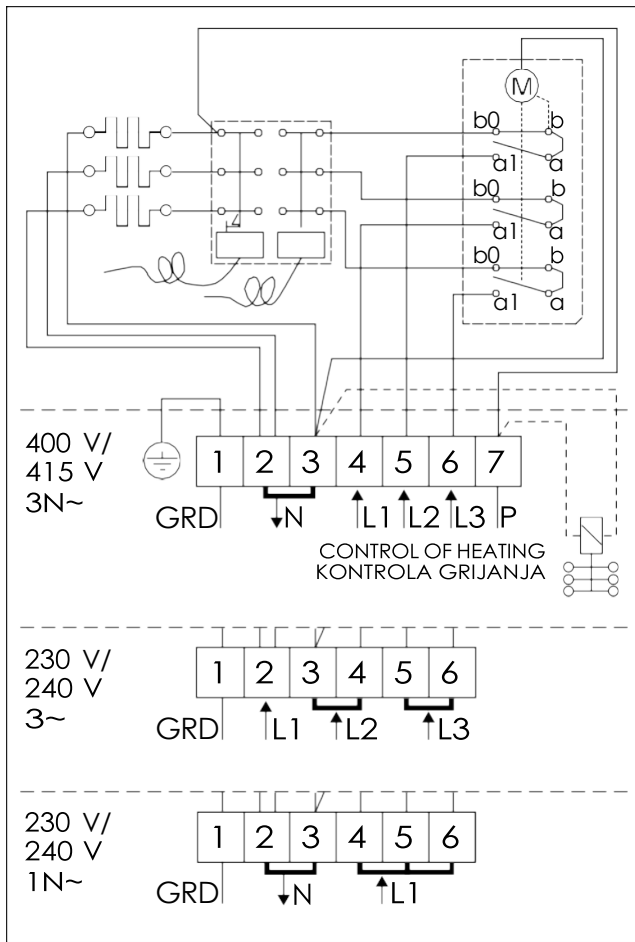

Figure 10. Electrical connections of BC heater
Foto 10. Električni priključci grijača BC

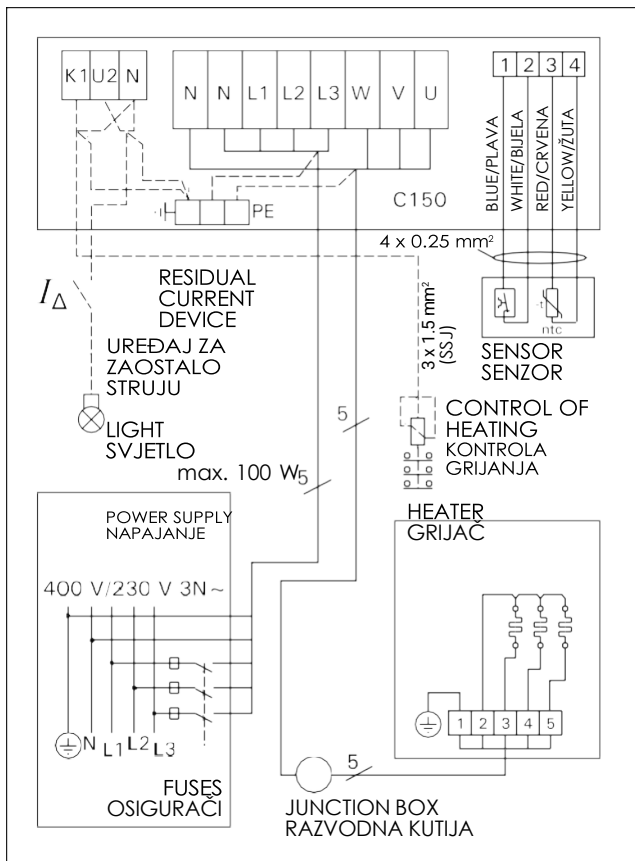

Figure 12a. 3-phase electrical connections of control unit C150 and BC-E heater
Foto 12a. 3-fazni električni spojevi upravljačke jedinice C150 i grijača BC-E

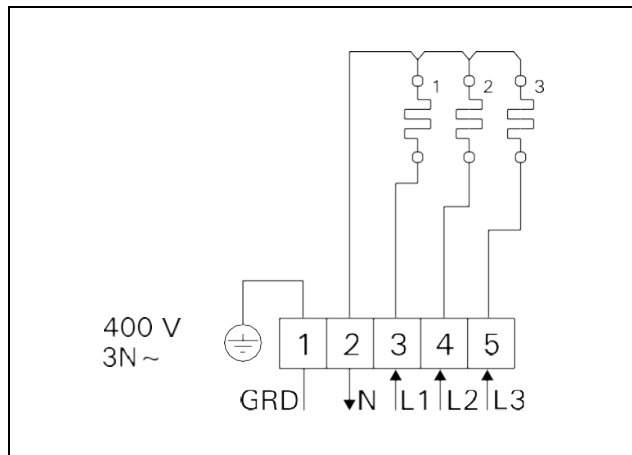

Figure 11. Electrical connections of BC-E heater
Foto 11. Električni spojevi peći BC-E

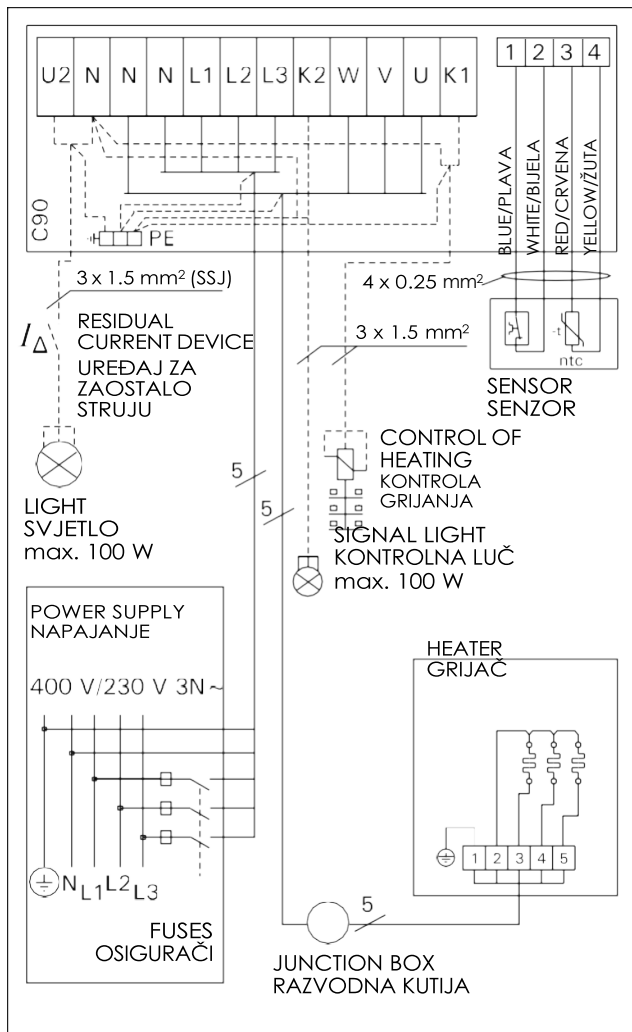
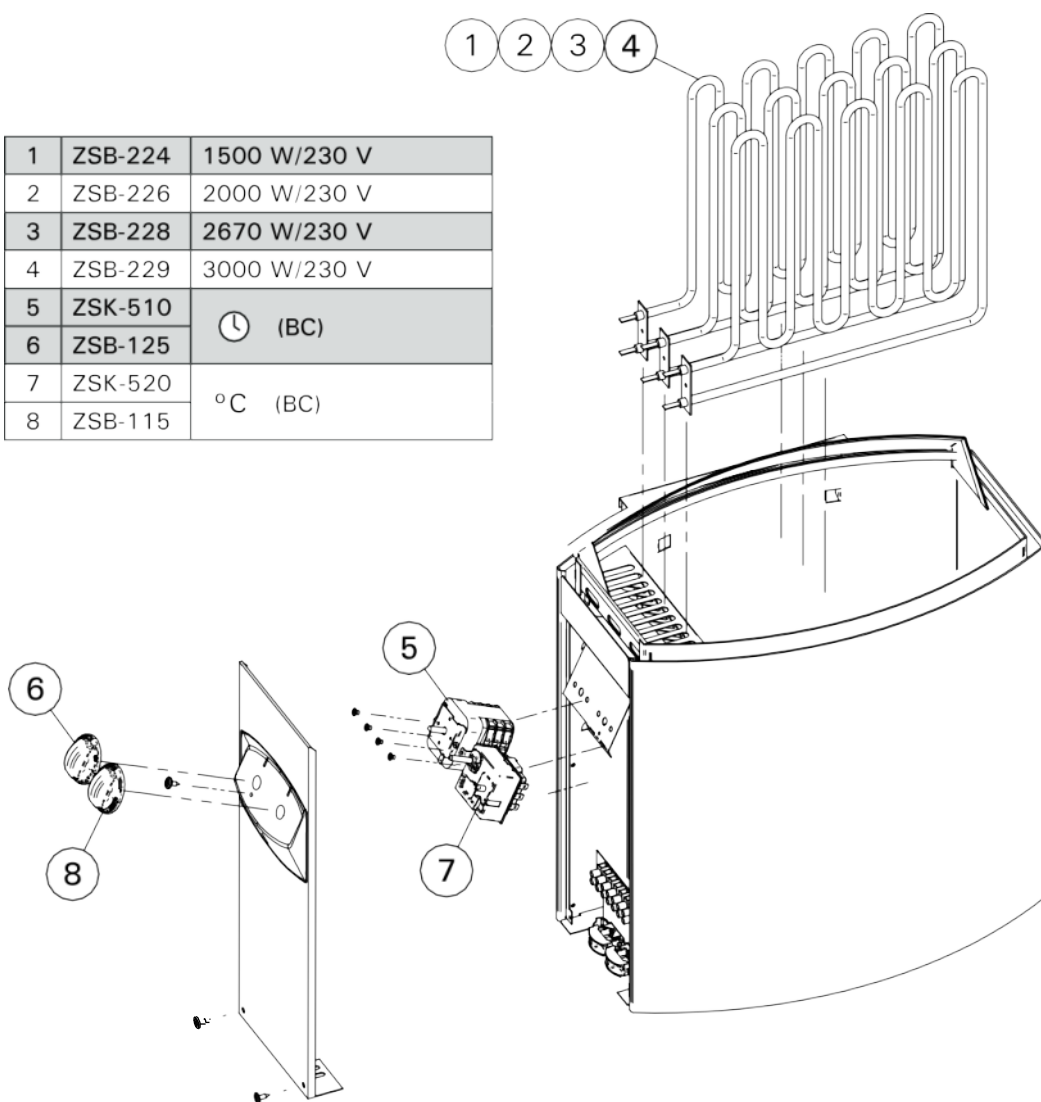

Figure 12b. 3-phase electrical connections of control unit C90 and BC-E heater
Foto 12b. 3-fazni električni spojevi upravljačke jedinice C90 i grijača BC-E

4. SPARE PARTS

4. REZERVNI DIJELOVI

1	ZSB-224	1500 W/230 V
2	ZSB-226	2000 W/230 V
3	ZSB-228	2670 W/230 V
4	ZSB-229	3000 W/230 V
5	ZSK-510	⌚ (BC)
6	ZSB-125	
7	ZSK-520	°C (BC)
8	ZSB-115	



HARVIA

Harvia Oy
PL12
40951 Muurame
Finland
www.harvia.fi

AT

Dieses Produkt enthält <2> Lichtquellen der Energieeffizienzklasse <G>

E

This product contains <2> light sources of energy efficiency class <G>

BG

Този продукт съдържа <2> светлинни източника с клас на енергийна ефективност <G>

HU

A termék <2> db <G> energiaosztályú fényforrást tartalmaz.

RO

Acest produs conține <2> surse de lumină din clasa de eficiență energetică <G>

SK

Tento produkt obsahuje <2> svetelné zdroje energetickej triedy <G>

CZ

Tento produkt obsahuje <2> světelné zdroje energetické třídy <G>

SI

Ta izdelek vsebuje <2> svetlobne vire energijske učinkovitosti razreda <G>

HR

Ovaj proizvod sadrži <2> izvor svjetlosti energetske učinkovitosti klase <G>